



RRC-1258 MkII(s)

Yaesu Twin, Elecraft K3-Twin etc.

User Manual



Table of contents

Statement of Conditions	7
General Description	8
Detachable control panel	9
PC-based control	10
Step by step system setup	11
Hardware	13
Front	13
Back	17
Strapping and jumpers	21
Configuration with Microbit Setup Manager	26
Initial IP setup via LAN	26
Changing IP-settings.	29
Initial IP setup via USB	32
FW/HW version	33
FW update.....	33
Setup	35
Net info.....	36
WiFi and Serial Port tabs	36
Initial IP setup	37
Configuration with WEB-interface	40
Info	41
Status.....	42
Profiles	44
IP Settings	47
Radio Settings	50
Serial Settings	56
Advanced settings	62
Dynamic DNS setting (only Radio-RRC).....	66
Remoterig dynamic dns service	66
DynDNS dynamic dns service	69
Keyer Settings (Control-RRC)	71
Keyer Settings (Radio-RRC).....	73
IO Settings.....	75
Ping settings (only Radio-RRC)	79
Wi-Fi settings	80
Export settings (HTML)	81
Export settings (bin).....	81
Import settings (bin)	82
Application firmware upgrade	83
Bootloader firmware upgrade.....	84
Restart device.....	84

Configuration with terminal-interface	85
WiFi.....	86
General	86
Connecting to a Wifi network	87
CW-Keyer	93
General	93
Settings	93
Connections.....	94
RTTY Keying	96
General	96
RTTY with MMTTY	98
Settings	100
Connections.....	101
ICOM CI-V	102
General	102
Hardware configuration	102
Radio settings (example)	103
Connections.....	103
ICOM IC-7100	107
General	107
Hardware configuration	107
Radio settings (example)	109
Connections.....	109
Power supply	110
Logging, computer control, RRC-Micro, RRC-Nano control	111
ICOM IC-703, IC-706.....	114
General.....	114
Hardware configuration	114
Radio settings (example)	115
Connections.....	115
Power supply	116
Prepare the separation cable to IC-703 and IC-706	118
ICOM IC-R2500	122
General.....	122
Hardware configuration	122
Radio settings (example)	122
Connections.....	123
Power supply	123
ICOM IC-E2820	126
General.....	126
Hardware configuration	126
Radio settings (example)	126
Connections.....	127
Using HM-133 Microphone.....	128

Power supply	130
ICOM ID-E880	133
General	133
Hardware configuration	133
Radio settings (example)	133
Connections.....	134
HM-133/880 Microphone adapter boards	134
Power supply	136
ICOM IC-2725	139
General	139
Hardware configuration	139
Radio settings (example)	141
Connections.....	141
Power supply	141
YAESU TWIN	144
General	144
Hardware configuration	145
Radio settings (example)	146
Connections.....	147
Logging or computer control, RTTY etc.....	149
YAESU FT-857	155
General	155
Hardware configuration	155
Connections.....	157
Power supply	157
YAESU FTM-350.....	160
General.....	160
Hardware configuration	160
Connections.....	162
Power supply	162
YAESU FT-7800/7900/8800/8900	165
General.....	165
Hardware configuration	165
Connections.....	167
Power supply	167
YAESU FT-897, FT-1000 etc.....	169
General.....	169
Hardware configuration	169
Radio settings (example)	170
Connections.....	170
YAESU in General (FT-2000)	175
General.....	175
Hardware configuration	175
Radio settings (example)	175

Connections.....	176
KENWOOD in General	180
General.....	180
Hardware configuration.....	180
Radio settings (example)	181
Connections.....	181
KENWOOD TS-480	185
General.....	185
Hardware configuration.....	185
Radio settings (example)	186
Connections.....	186
Power supply	187
Logging, computer control, RRC-Micro, RRC-Nano control	190
KENWOOD TM-D710(GE) /TM-V71	193
General.....	193
Hardware configuration.....	193
Radio settings (example)	194
Power supply	194
KENWOOD TM-D700	198
General.....	198
Hardware configuration.....	198
Radio settings (example)	199
Power supply	199
KENWOOD TS-2000	202
General.....	202
Hardware configuration.....	202
Radio settings (example)	203
Connections.....	203
Kenwood TS-590S(G)-Twin	207
General.....	207
Hardware configuration.....	208
Strapping is standard kenwood	208
Setup	208
Connections.....	209
ELECRAFT K3-Twin	212
General.....	212
Hardware configuration.....	212
Radio settings (example)	214
Connections.....	214
Logging or computer control, RTTY etc.....	217
ELECRAFT	222
General.....	222
Hardware configuration.....	222
Radio settings (example)	223

Connections.....	223
ALINCO DX-SR8 and DX-R8	227
General.....	227
Hardware configuration.....	228
Radio settings (example)	228
Connections.....	228
Power supply	229
RRC-1258MkII with 2-wire or 4-wire interfaces	230
General.....	230
Hardware configuration.....	230
Radio settings (example)	231
Connections.....	231
Power supply	231
Schematics I/O and PAD interface	232
MIC/AUX Interface Control-RRC MkII	233
Speaker output interface Control-RRC MkIIs	234
Speaker input interface Radio-RRC MkIIs	234
MIC/AUX Interface Radio-RRC.....	235
Networks and Firewalls.....	236
DMZ	237
Portforwarding	238
SIP ALG	239
Mobile Network Routers	240
How to check if the ISP uses Carrier-grade NAT (CGN)	240
Appendix B - COM-port Keyer interface.....	242
Appendix D - Technical Data	243
Appendix E - Safety and Regulatory Information	244
FCC Statement	244
Safety Notice.....	244
Disclaimer	245
FCC / CE - Declaration of conformity.....	246

Statement of Conditions

In the interest of improving internal design, operational function, and/or reliability, Microbit 2.0 AB reserves the right to make changes to the product described in this document without notice. Microbit does not assume any liability that may occur due to the use or application of the product(s) or circuit layout(s) described herein.

All parts of the software are property of Microbit 2.0 AB. The hardware design, schematics PCB layout, concept, graphics, user manual, etc. are property of Microbit 2.0 AB. The device may not be disassembled, copied or reversed engineered.

Copyright © 2010,2011,2012,2013,2014,2015,2016
Microbit 2.0 AB
All rights reserved.

General Description

The Remoterig RRC-1258MkII (RRC) is developed especially for remote control of Amateur radio stations via the Internet in a user-friendly and cost-effective way. The RRC units are used in pairs, one is connected to the radio (Radio-RRC) and the other is connected to the control equipment (Control-RRC). The system is unique in the way that no PC is needed for the voice and data communication it's handled by the two RRC. There are two versions available RRC1258MkII and RRC1258MkIIs, the difference is that the (s) versions handles two audio channels from the radio which is useful together with dual receiver equipment. The Remoterig system can be configured to work together with most Amateur radio stations available on the market from ICOM, Kenwood, Yaesu, Elecraft, Alinco and Tentec. The Remoterig system fits very well in the following situations:

- You are not allowed to put up antennas at your home.
- The noise level is too high to make Amateur radio activity possible.
- You want to build so big antennas that can't be done in urban areas.
- You do not want to be dependent of PC:s for the remote control.
- Etc.

The Remoterig system itself will not introduce any latency and the latencies introduced by Internet and buffering will rarely be any noticeable problem. The Remoterig system also includes a unique solution for operating CW over Internet and it also includes a CW-keyer. The Remoterig system is connected to the Internet primarily via 10 or 100 Mbit Ethernet and fixed connections like DSL, cable and WLAN. 3G based mobile solutions will also work but sometimes with reduced performance. The system is portable and you can use it from almost any network connection in the world. Session control, audio (VoIP) and data is transferred using standardized protocols like SIP, RTP etc. where you can select different audio qualities depending on available bandwidth. The RRC-1258MkII is easily configured via modern USB and WEB based user interfaces.

Detachable control panel



You will get the ultimate function of the Remoterig system together with radio stations with detachable control panels like Elecraft K3/0-mini-K3/100, Kenwood TS-480, Kenwood TM-D710, Kenwood TS-2000, Yaesu FT-857, ICOM IC-7100, IC-703, ICOM IC-706, IC-2820 and Alinco DX-SR8. You simply replace the cable between the control panel and the radio with the Remoterig system. You will get the same feeling and functionality as with the original setup.

TWIN

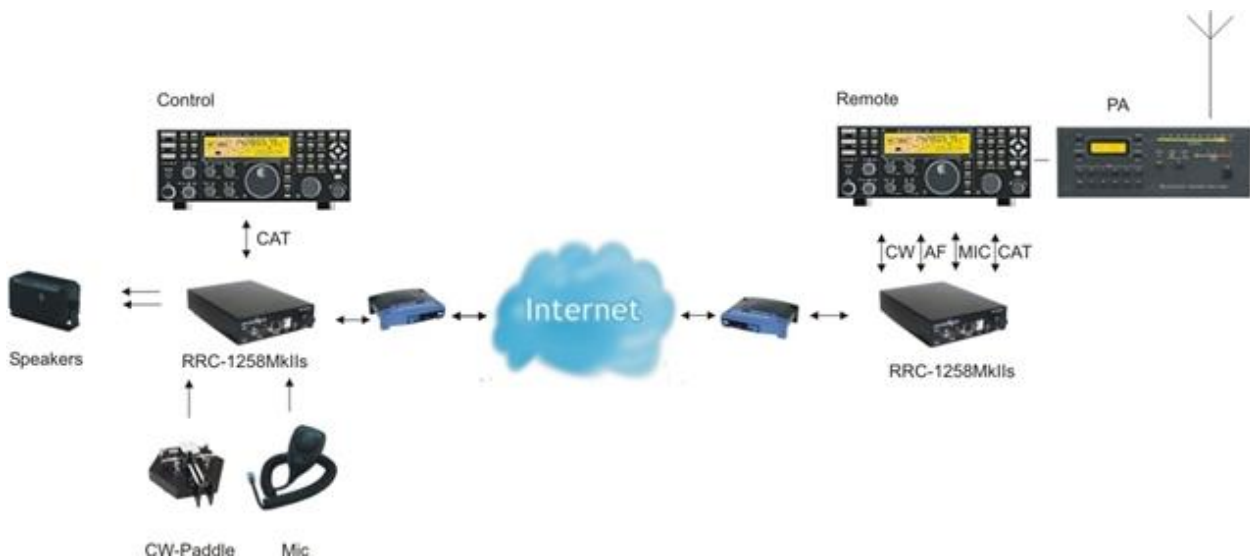

The twin solution for Elecraft K3 and Yaesus is the high end solution for the DX-er or contester who do not want to compromise in the selection of radio. The Twin solution is based on the idea that one local radio controls the remote radio and you get the feeling that you have the radio at your control site. For the Elecraft K3-Twin solution there is also a special K3 called K3/0-mini available which is specially designed to use as control as it has no RF-parts.

PC-based control

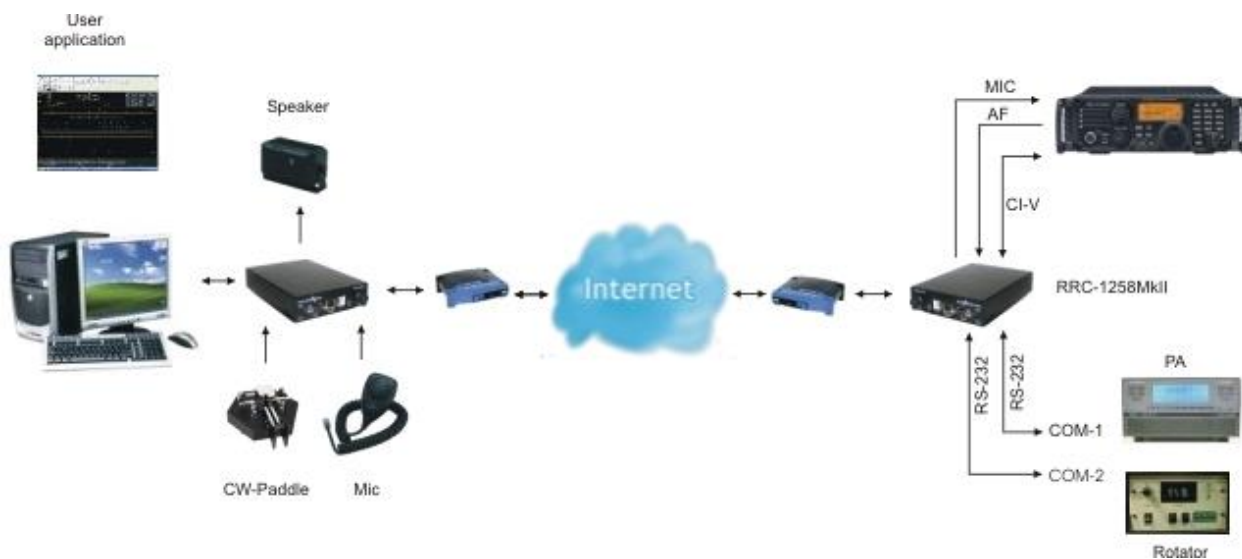

The system also works very well for more traditional remote control from PC-based control software's like HamRadioDeLuxe. The Remoterig system solves the voice and data transmission but you need a PC for the Control software itself in this setup.

Step by step system setup

Below follows a recommendation about how to proceed when setting up the system.

1. Spend some time to read thru this user manual to get familiar with the product.
2. Apply 12V DC (good stabilized power) to both units.
3. Connect both units with CAT5 patch cables to the same Ethernet switch or router as your PC which you will use to setup the system is connected.
4. Download the Microbit Setup Manager and the latest firmware from <http://www.remoterig.com> to your PC. Follow the instructions about how to install the Microbit Setup Manager (see chapter [Configuration with Microbit Setup Manager](#)).
5. Find out how your network is configured and configure the RRC to fit into your network (see chapter [Initial IP Setup via LAN](#)) with the Microbit Setup Manager. This has to be done with both units.
6. When you have configured the units to fit into your network, Start your Web browser and connect to the units one by one by entering their resp. IP-address. If you get in contact with their internal web server everything is OK. (You can also use the Browse button in the Setup manager)
7. Check the installed firmware version. If the one you downloaded from Remoterig is newer, update the units with the new firmware. Always update both units to the same version (see chapter [FW/HW](#) about how to update).
8. Disconnect all cables from the units and open the housings (see chapter [Strappings and jumpers](#)) and make the hardware strapping according to the instruction which is provided in the chapter for your radio in the end of this User manual. Check the red jumpers with a ohm meter to verify that they are not broken before assembling the housings again.
9. Make the basic software configuration for your system which is described in the chapter for your radio in the end of this Users manual.
10. Prepare the cables needed for your radio station and/or PC according to the cable drawings provided in the chapter for your radio in the end of this User manual. Double check your home made cables with an ohm meter before connecting them to the RRC and the radio to prevent harm of any equipment. Microbit do not take any responsibility of damaged RRC-units or radio equipment.
11. After preparing the cables connect them to the RRC-units and the radio equipment. Connect the power to all equipment. Check with your web browser again that you are in contact with both RRC-units.
12. Now try to establish the connection between the Control-RRC and the Radio-RRC. If you use a radio with a detached control panel it's done when you press the ordinary power on button. If you are using a PC-at the control end you need to browse to the status page in the Control-RRC and connect by clicking on the "Connect" button on.

13. When the connection is established, test the functionality. Check that you can hear the receiver audio, check that PTT is working and microphone level is OK to be sure that the strappings are OK.
14. When this basic functionality are OK you can go further connecting cables for CW, rotor control, PA-control etc. Prepare all functions that you need and test them before moving the RRC:s apart to different locations, everything gets much more complicated to test when travelling is needed.
15. When it's time to move the RRC:s apart you need to gather some information about how the network at the remote site is configured. The first thing is to determine if your Internet Service Provider (ISP) are providing a fixed or dynamic IP-address. Fixed IP:s are rare so you probably have a dynamic IP-address if you are not paying extra for a fixed one. A dynamic IP is no problem but you need to use a dynamic DNS service. You can use Remoterigs free dynamic DNS service or a DynDNS account. DynDNS account is no longer free. For detailed information about Dynamic DNS services see the [Dynamic DNS chapters](#) under Configuration with WEB-Interface. **Note!** If you plan to use 3G or 4G connection at the radio side, read the chapter about [Mobile Network Routers and Carrier-grade NAT](#)
16. After moving the RRC-apart you need to connect a PC to the local network at the remote site where the Radio-RRC should be connected and find out how the network is configured (see chapter [Initial IP Setup](#)). You have to set up the new IP, Netmask and Gateway. When it's done use your web browser to connect to the Radio-RRC:s internal web server and configure the DNS IP.
17. Configure the Radio-RRC:s Dynamic DNS settings (see chapter [Dynamic DNS Setting](#)).
18. Now it's time to configure your remote router. We recommend that you first of enable the remote configuring of your router, you may need it later. After that's done configure DMZ or port forwarding (see chapter [Network and Firewalls](#)). When this is done your remote Radio-RRC should be reachable over the Internet.
19. When back at the Control QTH try to browse to the Dynamic DNS address (Own host name) you have setup at the Radio-RRC. You should get in contact with the Radio-RRC internal web server exactly as it was local.
20. The only setting which need to be changed in the Control-RRC is the SIP-contact at the Radio settings page. The SIP-contact should be changed to the Dynamic DNS "Own host name" you have setup in the Radio-RRC or to the fixed IP of the Radio QTH if you have one. Then everything should work remotely.

Enjoy the remote controlling.

Hardware

Front



PWR LED

Green light is indicating normal status. When the green LED is flashing slow the unit is trying to connect to the Ethernet, normally it only takes a few seconds. If the LED do not end flashing it's probably something wrong with the network connection or network setup. A fast flashing power LED indicate that the unit is powered from USB (see USB below).

USB

The USB-interface is used to initially set up the IP parameters. It can also be used for downloading new software (can also be done via the WEB-interface). At the Control-RRC it can also be used for CAT control, PTT, RTTY or CW control via the RTS and DTR signals in the virtual COM-port delivered by the RRC USB device. From Version 6 the RRC can be powered via the USB to make it easier to update the Firmware. Note that the RRC need to be connected to 12V DC for normal operation. When the unit is powered from the USB the green power LED will flash fast.

COM1

COM1 can in special cases be used to set parameters and check statuses if USB or WEB cannot be used. The COM1 port can also be used for ex. rotator control as it can be configured as transparent serial port between the RRC:s.

RS-232

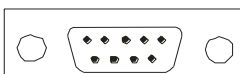

Pin no	RS-232 Interface (9-pol D-sub female)
1	
2	TXD (Out)

3	RXD (in)
4	
5	GND
6	
7	CTS (In)
8	RTS (Out)
9	

AUX/MIC

The AUC/MIC connector (RJ-45) is used for microphone connection or for connection of the radio control panel (IC-703/706, DX-SR8). Inside the RRC behind the connector is a set of straps with can be used to decide how the connector should be configured depending on radio or microphone. The red and yellow LED:s are indicating SIP-status:

LED	LED Red	LED Yellow
Off	Incoming audio stream OK	SIP disconnected
Flashing	-	SIP connection failed
On	Incoming audio stream fail	SIP connection OK

AUX/MIC

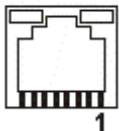

Pin no	AUX (RJ45)
1	depends on the inside straps
2	depends on the inside straps
3	depends on the inside straps
4	depends on the inside straps
5	depends on the inside straps
6	depends on the inside straps
7	depends on the inside straps
8	depends on the inside straps

TTL Control-RRC

The TTL connector on Control-RRC (RJ-12) is used primary for connection of the radio control panel (TS-480, RC-2000 and IC-E2820) and in other cases where you need to connect via a TTL level (5V) port. The connector is configured so a straight cable can be used to a TS-480 and RC-2000 control panel.

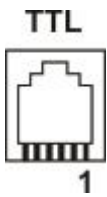

Pin no	AUX (RJ45)
6	AF output, Speaker 2W/8 ohm
5	TDO input, data from panel to radio (TTL)
4	RDO output, data from radio to panel (TTL)
3	GND
2	8V output, always active
1	GND

TTL Radio-RRC

The TTL connector on Radio-RRC (RJ-12) is used for connection of the cable which is normally connected between the control panel and the radio (TS-480, RC-2000, and IC-2820). It's also used for CAT control of radios with 5V.s inputs e.g. all ICOM with 3.5mm C-IV connector and FT-8x7 with the mini DIN-connector. The connector is configured so a straight cable can be used to a TS-480 control panel and to RC-2000.

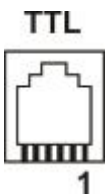

Pin no	AUX (RJ45)
6	AF Input (TS-480)
5	TDO input, data to radio (TTL)
4	RDO output, data to radio (TTL)
3	GND
2	8V output, always active
1	GND

SP Control-RRC

At the Control-RRC the connector is used as a speaker output. It's connected in parallel with the audio output pins in the MIC/AUX and TTL connectors. The connector is a standard 3.5 mm jack for a mini stereo plug and there is no switch in the connector. The speaker output power is 2W at 8 ohm. In the dual RX (stereo) version there are signals from both the Main-RX and Sub-RX available in the SP-connector. There is only a Lf power amplifier on the Main RX signal so I recommend that you set jumper JMP-4 in the Headset position and use headset

or Stereo speakers with built in If-power amplifier if you use a Dual Receiver system. PC-type speakers are very well suited for this.

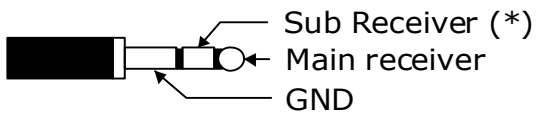

(*) Sub receiver, only available in RRC-1258MkIIs version

SP Radio-RRC

At the Radio-RRC the speaker connector is an input for the speaker signals from the radio. The Dual-Rx version has inputs for both the Main-Rx and Sub-RX. The Main-Rx input is connected in parallel with the input pins in the MIC/AUX and TTL connector. The inputs has resistive loads of 50 ohms. The connector is a standard 3.5 mm jack for a mini stereo plug and there is no switch in the connector.

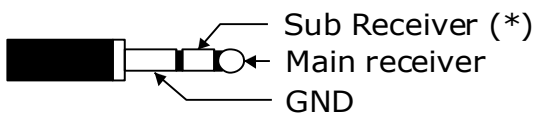

(*) Sub receiver, only available in RRC-1258MkIIs version

CW Control-RRC

The CW knob is used for adjusting the CW-speed of the built in CW-keyer. The CW –Speed adjustment is also connected to the WinKeyer emulator. There is no knob on the Radio-RRC.

Back



COM2 Control-RRC

COM2 is used to connect to a PC COM port (RS-232). It has a female connector which makes it possible to use a straight cable between RRC and PC. The communication parameter is set via the web interface.

RS-232

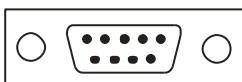

Pin no	RS-232 Interface for PC connection (9-pol D-sub female)
1	
2	RXD (out) to PC RXD
3	TXD (in) from PC TXD
4	
5	GND
6	
7	RTS - connected to JMP-3
8	CTS - connected to JMP-3
9	

COM2 Radio-RRC

COM2 is used to connect to a Radio with RS-232 port. It has a male connector, which makes it possible to use a straight cable between RRC and the radio. The communication parameter is set via the web interface.

RS-232

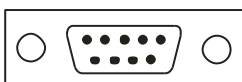

Pin no	RS-232 Interface for Radio connection (9-pol D-sub male)
1	
2	RXD (in) to pc RXD
3	TXD (out) from pc TXD
4	
5	GND
6	
7	RTS - connected to JMP-3 (*)
8	CTS - connected to JMP-3 (*)
9	

(*) Both Kenwood and Yaesu transceivers need the RTS and CTS pins to be strapped together. JMP-3 inside the box can be used to strap them if you want to use a standard fully connected cable.

PAD Control-RRC

At the Control-RRC the input is used to connect a CW-paddle. The input is for a standard 3.5 mm stereo plug. Normally the left paddle is connected to the tip and the right paddle to the ring. Common is connected to the inner ring and ground. Note that the CW-Keyer function must be enabled to activate this function.

PAD Radio-RRC

At the Radio-RRC the output is used to connect the output signal from the CW-keyer to the radio straight KEY input. The output is for a standard 3.5 mm stereo plug. A standard cable with 3.5 mm connector in both ends can often be used. Note that the OUT1 mode or OUT2 mode must be set to Keyer to activate this function.

PWR

The RRC is powered via the PWR connector (2.1/5.5 mm) with 10-18 VDC.

Radio	Control-RRC (12 VDC)	Radio-RRC (12 VDC)
IC-706	up to 600mA, depending on back lighter and audio volume	max 160 mA (110mA 10Mbit)
TS-480	up to 500mA, depending on audio volume	max 160 mA (110mA 10Mbit)
RS-232	up to 400mA, depending on audio volume	max 160 mA (110mA 10Mbit)

12V DC
- ⊕ +

Pin no	PWR
+	+ 10-18 VDC (centre)
-	GND

RESET

A short press on the reset switch will reboot the unit. By pressing and keep the button pressed for 20 sec the unit reset to factory default settings with the following network settings:

Control-RRC IP-address: 192.168.0.227
 Radio-RRC IP-address: 192.168.0.228
 Netmask: 255.255.255.0
 Gateway: 192.168.0.1
 DNS: 192.168.0.1

I/O

In the I/O connector is 3(2) inputs and 3 outputs, 8V and GND available (see below). The connector is used for transferring signals from one RRC to the other. If the CW-keyer function is not used the connector can be used for whatever controls signals needed in both directions. The output transistor can sink max 200mA so install an external relay if it's not strong enough.

I/O

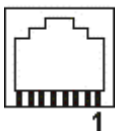

Pin no	I/O (RJ45)
1	IN1, active low (CW-Keyer right-paddle)
2	IN2, active low (CW-Keyer left-paddle)
3	OUT2, open collector (parallell with PAD Tip at Radio-RRC)
4	IN0, active low (only available at Control-RRC)
5	OUT0 open collector
6	OUT1 open collector (parallell with PAD Ring at Radio-RRC)
7	8V OUT (max 100mA)
8	GND

ETHERNET

The unit can be connected to both 10 and 100 Mbit/s Ethernet based TCP/IP network. The RRC can be configured for different connection types for Ethernet port, Auto, 10HDX, 10FDX, 100HDX, 100FDX and Auto-with-preferred-10FDX. Default is Auto-with-preferred-10FDX which works best in most cases.

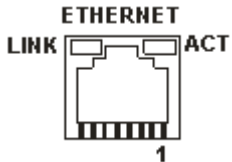

Pin no	Ethernet (RJ45)
1	Out [+]
2	Out [-]
3	In [+]
4	
5	
6	In [-]
7	
8	
LINK	Green LED indicates link OK flashing LED indicates traffic
ACT	Yellow LED indicates speed = 100Mbit/s (off = 10Mbits/s)

Strapping and jumpers

Before connecting the RRC to your radio you need to put some straps in place depending on your radio. Down below follows instructions of how to disassembly the RRC and pictures showing where to find the different straps.

1:

Start with removing the screws holding the D-sub on the rear marked COM2. The tool should be 5 mm (3/16").



2:

Open the box by pressing the D-sub until you can get your fingers behind the edge of the lid and can slide the housing apart.



3:

Behind the AUX/MIC connector there is a strapping area which looks like an IC-socket. There are two rows with 9 holes. The row next to the AUX/MIC connector is connected to the connector. The strapping is done by connecting the red strap wires, supplied with the RRC, between the holes according to the description for the radio (see radio chapter). Normally the same strapping should be done in both Control-RRC and Radio-RRC. (The picture shows the strapping for IC-706). **Attention! The strapping wires should NOT be soldered.** Just push them into the socket. The mechanical friction is enough to get connection.

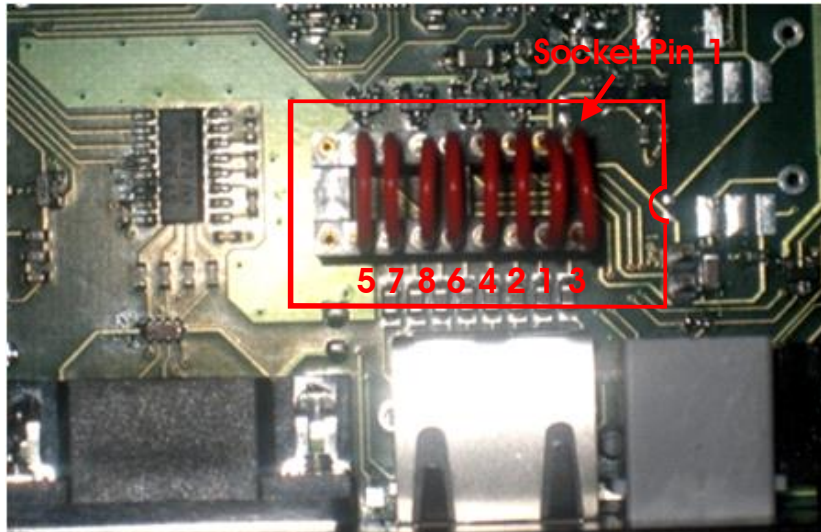

4:

Control-RRC only: JMP-1 is placed behind the TTL connector. With the strap in place a DC voltage is feed to the microphone element. All ICOM microphones should be DC-feed. Dynamic microphones like the ones used by Kenwood should not be DC-feed. HEIL microphones should not be DC-feed either.

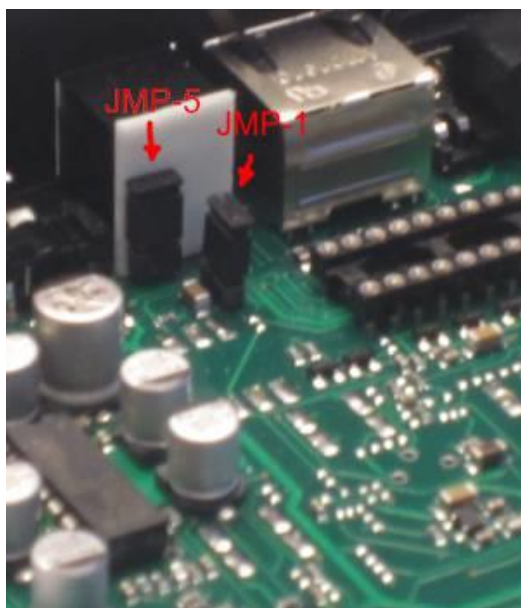

5:
Control-RRC only: JMP-2 is placed near the back of the RRC next to the RESET button. JMP-2 is used to select if the DC-power to the front panels should be 8 or 9 V. With the strap in place it will be 8V, which fits all ICOM radios. Without the strap the voltage will be 9V, which fits Kenwood TS-480 and RC-2000 panels that need 9V for the back-lighter.



6:
JMP-3 is placed next to the rear D-sub COM2. JMP-3 is used to connect RTS and CTS together (pin 7 and 8) in COM2. Most of the Yaesu and Kenwood radios with RS-232 port need to have them tied together. This is convenient if you want to use a prefabricated fully connected cable.



7:

Control-RRC Only: JMP-4 is placed behind the CW-pot, and is available only in the Control-RRC and are only present in the RRC-1258MkIIs up to Hardware version 5. JMP-4 is used to select between Speaker level or Headset level for the Main-Rx output. The Sub-Rx is always Headset level. From hardware version 6 it's always speaker level from both RX.



8:

JMP-5 is placed behind the TTL connector and is only present in the RRC-1258MkIIs from hardware version 7. JMP-5 is used to decide if pin1 in the TTL connector should be grounded or not. It should be grounded (in place) for all Radios but Yaesu FT-857 and ICOM ID-E-880

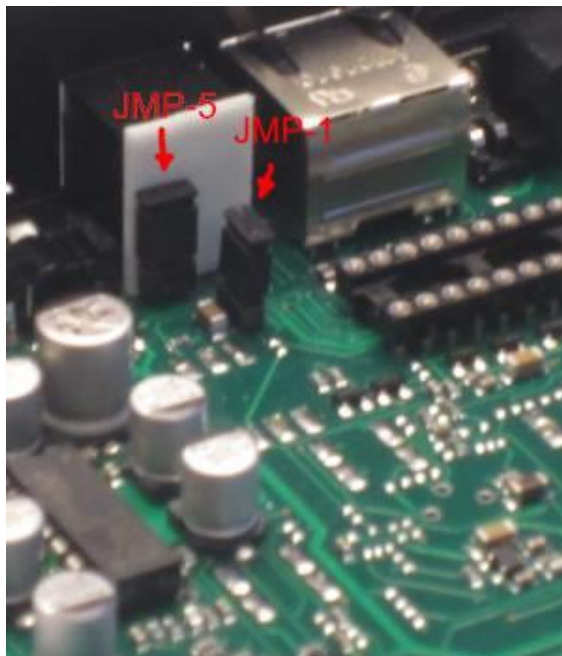

9:

When you are done you can slide the lid on the bottom part and put back the screws. Be careful the threads do not stand to much force.



Configuration with Microbit Setup Manager

The initial settings of the network parameters are easiest done with the Microbit Setup Manager. The Setup Manager is a software which runs under Windows on a PC and connects to the RRC via USB (an USB cable is supplied with the RRC). The Setup Manager can be used for:

- IP Settings and verification
 - IP-address
 - Netmask
 - Gateway
 - DNS
 - DHCP
- Firmware upgrade
 - Application
 - Bootloader
- Changing profile
- Scanning for WiFi networks and WiFi setup.

Start with downloading the Microbit Setup Manager from the homepage www.remoterig.com. Install the Microbit Setup Manager by following the instructions which shows up. If you have an old version of Windows XP where Netframework 2.0 is not installed, you have to install Netframework from Microsoft before installing the Setup Manager. When you have finished the installation a new shortcut to the Setup Manager will show up on the desktop. Click on the icon to start Setup Manager



Initial IP setup via LAN

Do not install any WiFi cards yet. Connect both your RRC:s to 12V and connect both to the same Ethernet switch or router as your configuring PC is connected to.

To do the Initial IP setup over the LAN a RRC firmware version from v2.79 or later are required. If you install a new set of RRC:s this is no problem but if you have a set of used RRC:s you may need to use USB to first upgrade them to the latest firmware ([see chapter about USB configuration](#)).

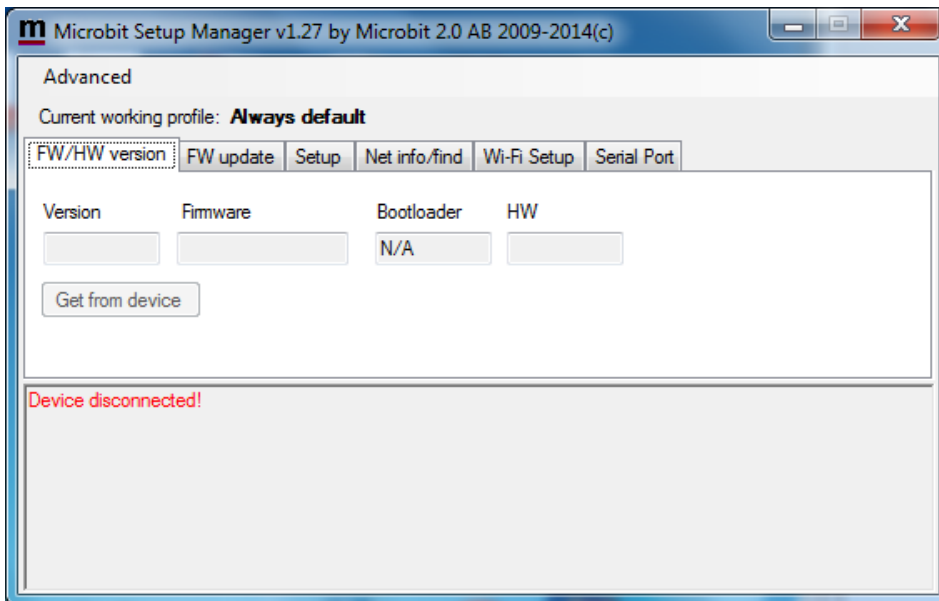

Click on the Net info/find Tab

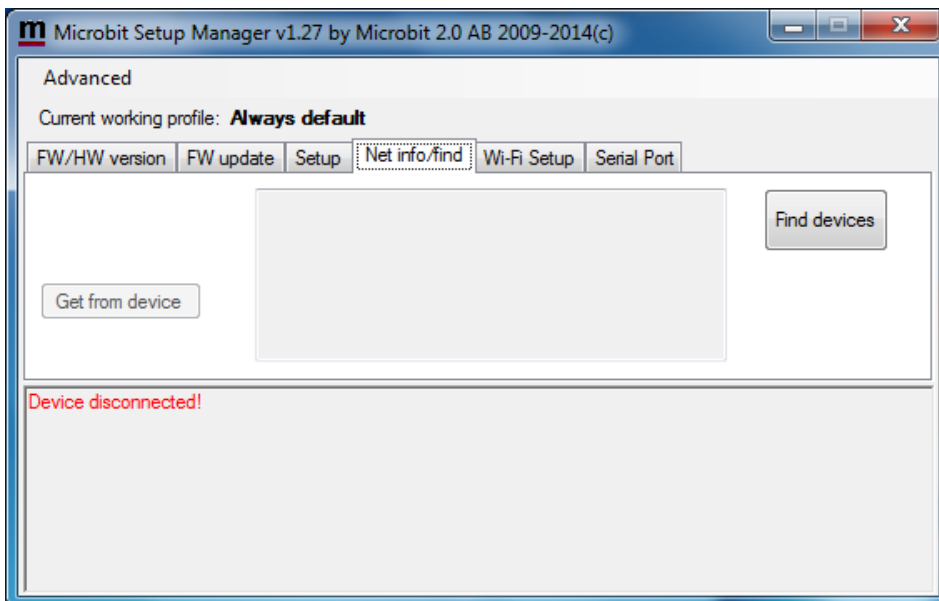

Click on the "Find devices" button"

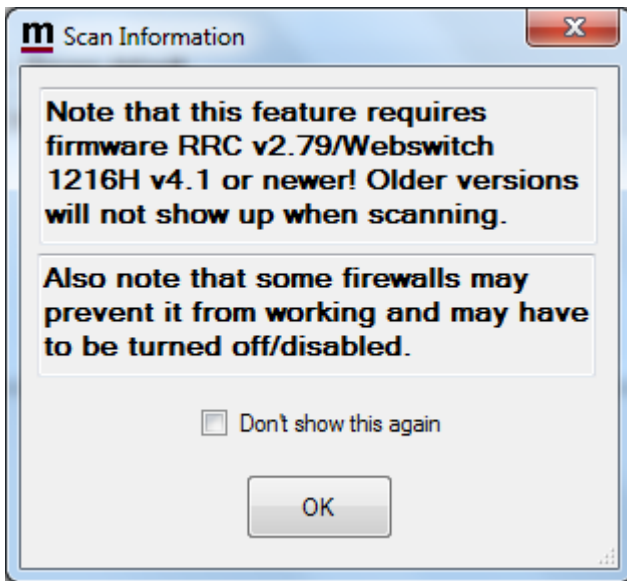

A reminder pop up that it requires a firmware version from 2.79 or later. If you install a new set of RRC:s this is no problem but if you have a set of used RRC:s you may need to use USB to first upgrade them to the latest firmware (see chapter about USB configuration).

Click OK

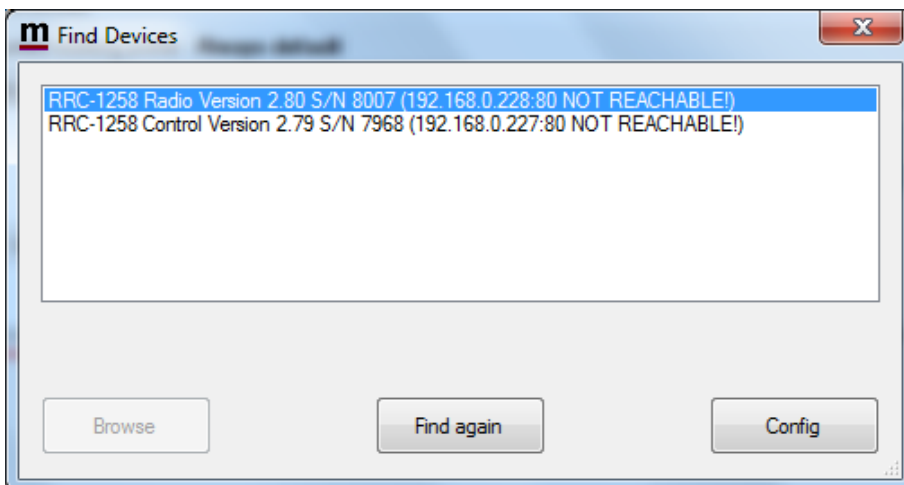

After a while the Setup manager will find the RRC:s

If the text "NOT REACHABLE" shows up after the IP number, then the RRC default IP:s are not in the same logical network as the PC you are configuring and you have to change them. If they are reachable and you are satisfied with the IP-numbers you can skip the Change IP-settings procedure and go direct to.....

Changing IP-settings.

Select the RRC you want to configure by clicking on the row. The selected row will change to blue.

Click on the "Config" button

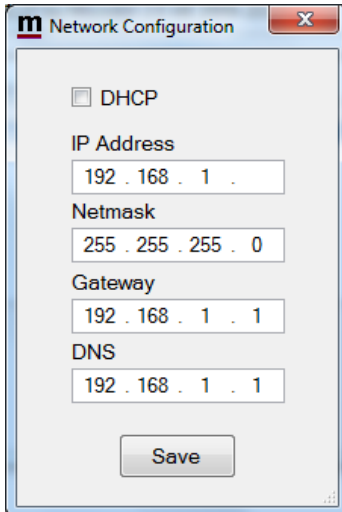

A "Network Configuration" dialog window will pop up. The Netmask, Gateway and DNS settings will be filled in already, they are copied from your PC:s Networks setting and normally do not need to be changed. The first 3 groups of the IP number are also filled in to match your PC-network settings.

Give the RRC a IP number by entering a number between 2 and 254 in the position for the last group. We suggest you use the default numbers 227 for Control-RRC and 228 for Radio-RRC if they are not already occupied in your LAN, then it's easier to follow the manual.

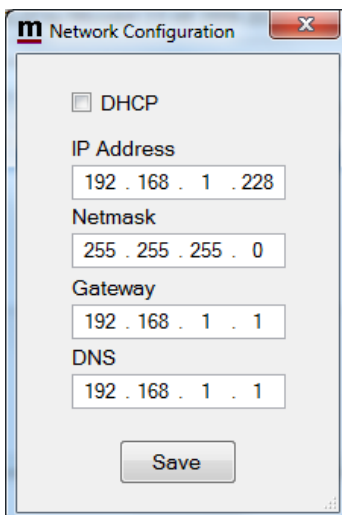

As we selected the Radio-RRC first we enter 228 and click the "Save" button.

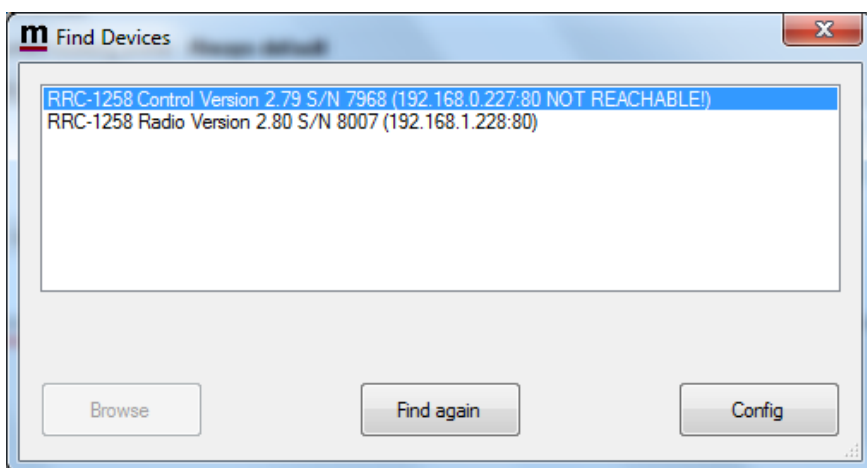
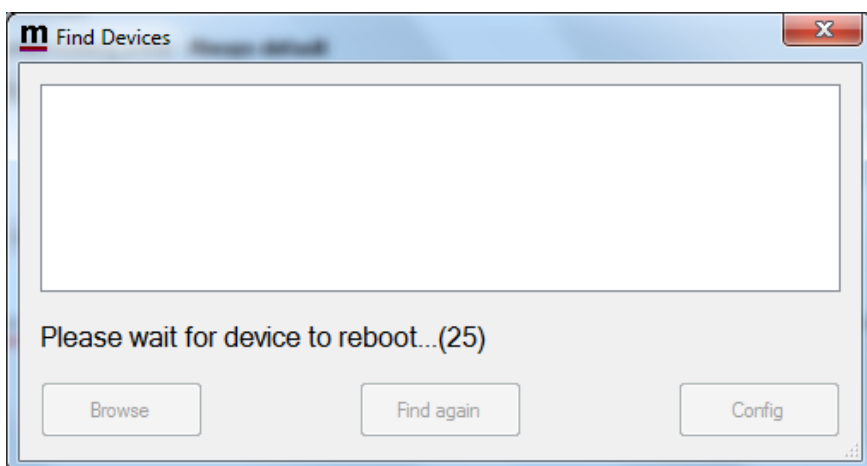

The RRC will reboot, when it's rebooted the "Find Devices" window will show the new IP (in this example 192.168.1.228) and the "NOT REACHABLE" text will not be shown.

Now do the same procedure for the Control-RRC.

Select the row for the Control-RRC and click on the "Config" button

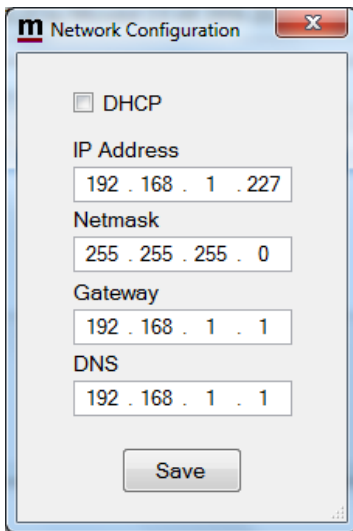

Enter 227 in the last group and click "Save"

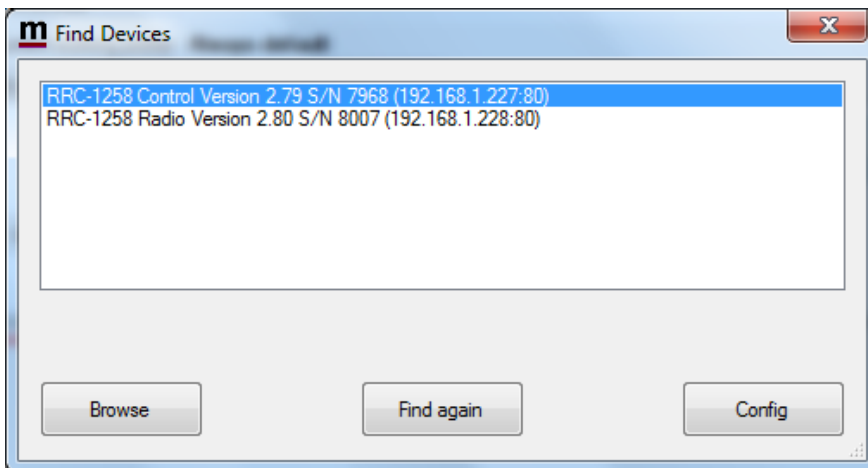

After the RRC has rebooted, the "Find Devices" window will show the new IP (in this example 192.168.1.227) and the "NOT REACHABLE" text will not be shown.

Now both RRC are reachable over the LAN.

Check the connectivity by clicking on the corresponding row and click on the "Browse" button

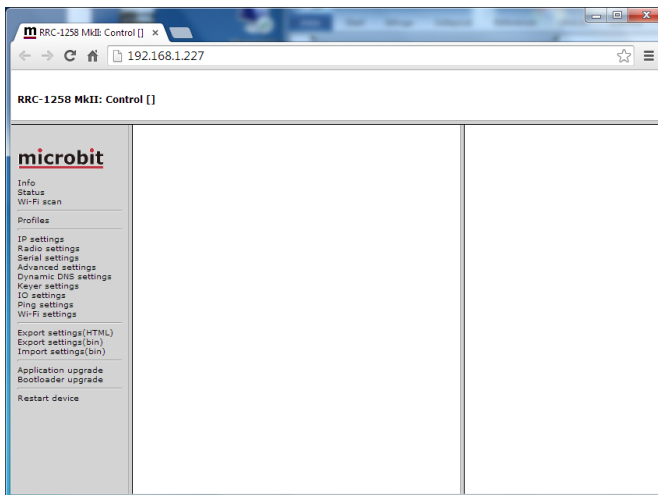

The Internal webserver in the RRC will produce a web page like the one above.

Note ! If you have changed the IP-address of the Radio-RRC from the default IP address like in the example above, remember that you need to change the "SIP-contact" IP-address in the Control-RRC at the Radio-settings page.

You can now start the configuration via the web

[Back to Step By Step setup system setup](#)

Initial IP setup via USB

The initial IP-setup can be done from the Microbit Setup Manager via USB also. This is the way it had to be done in past. This method is a little bit more complicated for beginners but can be convenient to use sometimes as no networks connection are needed with this method.

If your RRC has an old firmware (before 2.79) you can upgrade the firmware via the USB interface before you do the setup (see below).

Connect your RRC to 12V and connect the USB-cable between your computer and the USB jack on the front of the RRC. Windows will automatically install the necessary drivers. When it's done the text in the bottom field will change from "RRC not connected" to "RRC-connected" which is an indication that you are in connection with the unit.

FW/HW version

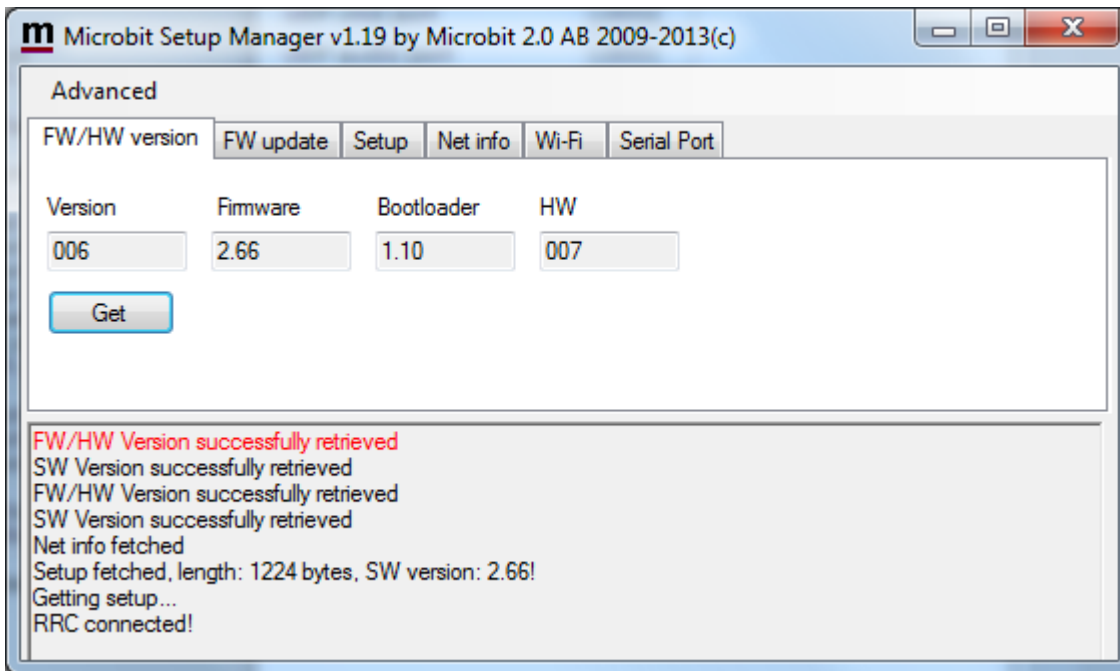

When you connect the RRC the version of the firmware and Bootloader will show up in the upper window. The hardware versions is also shown. Go to the page www.remoterig.com and under downloads you can find the latest firmware. If there is a newer firmware available download it to your desktop unzip it and change to the "FW-update" tab.

FW update

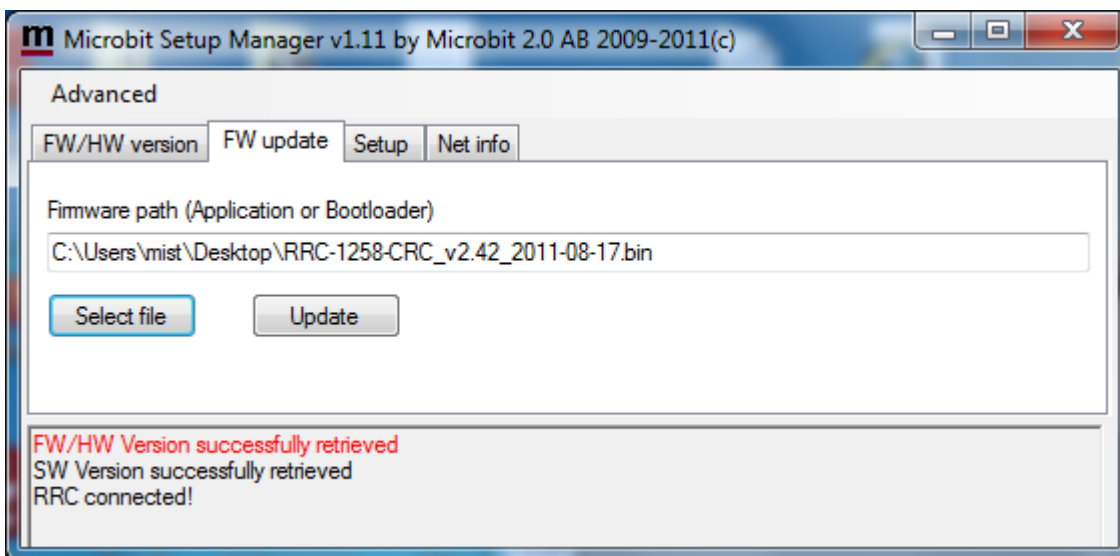

Click on the "Select file" button and browse to the file with the new firmware, it should be something like "RRC-1258-CRC_v2.42_2011-08-17.bin" depending on the version and release date. When you have selected the file click on the "Update" button and the update process will start, the text in the bottom field will change to "Updating firmware". Attention -- Do not interrupt the update process in any way!

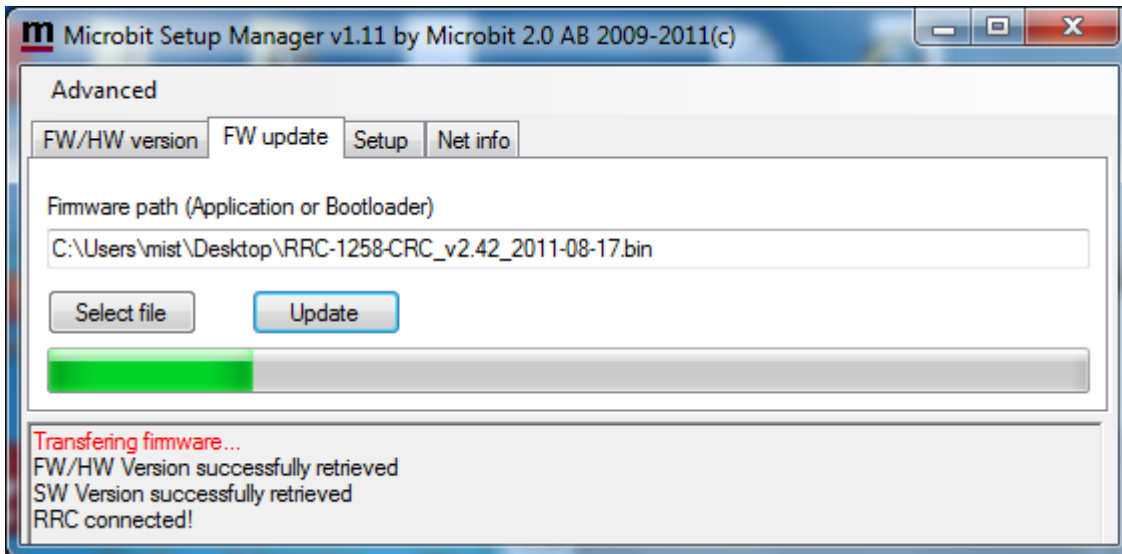

After about a 1 minute the update is finished and the RRC will restart. When the text "RRC-connected" shows up again in the lower field of the Microbit Setup Manager, you can change to the "FW/HW" tab and check software version.

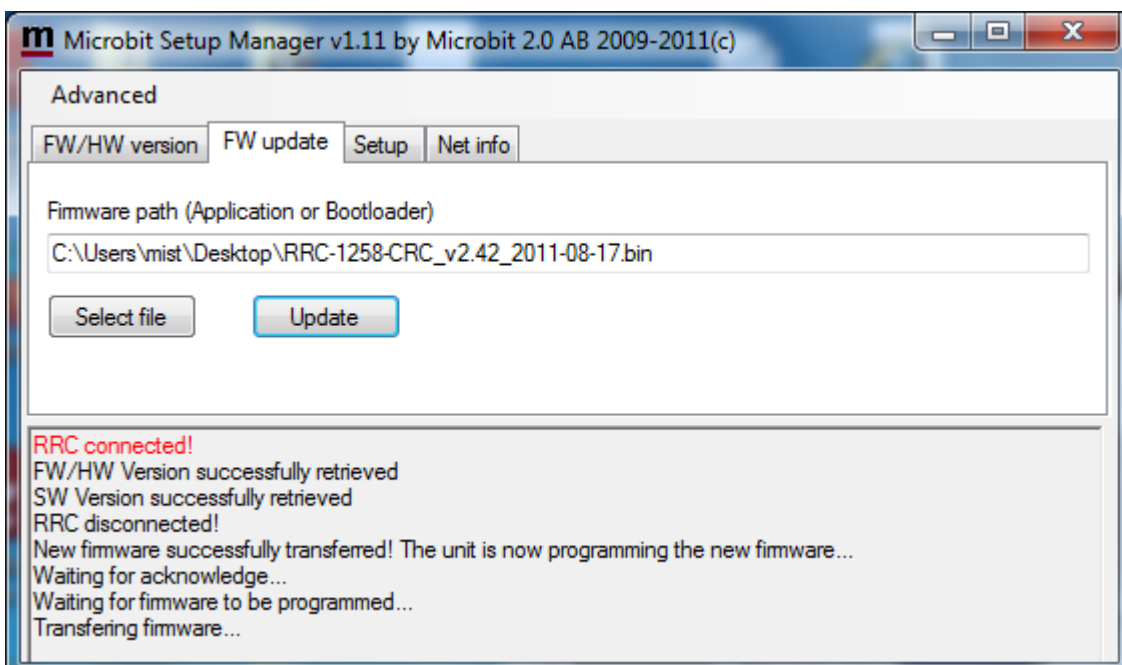

Setup

The setup tab are used to setup the IP address and/or select the profile (from v2.44). More info about the IP setup see Initial IP-setup.

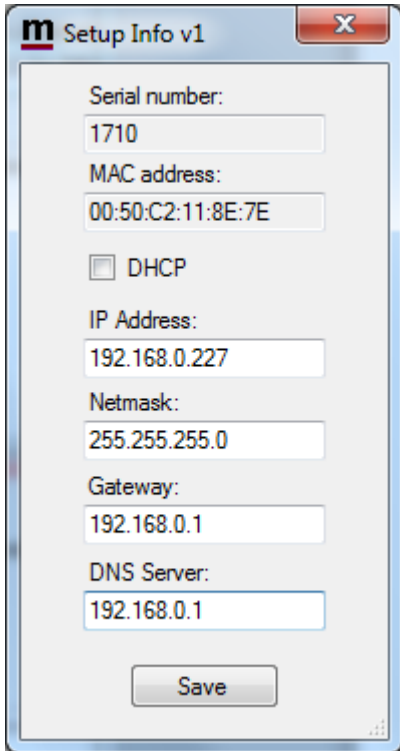

A new window will pop-up with the basic IP settings. Change the settings so they fit into your local network and press the "Save" button to save the new settings. The RRC will restart again and when the text "RRC-connected" shows up again in the lower field of the Setup Manager, you can click on the "Setup" button again to verify the changes.

Net info

Click on the "Get" button to read the IP setting currently in use by the RRC.

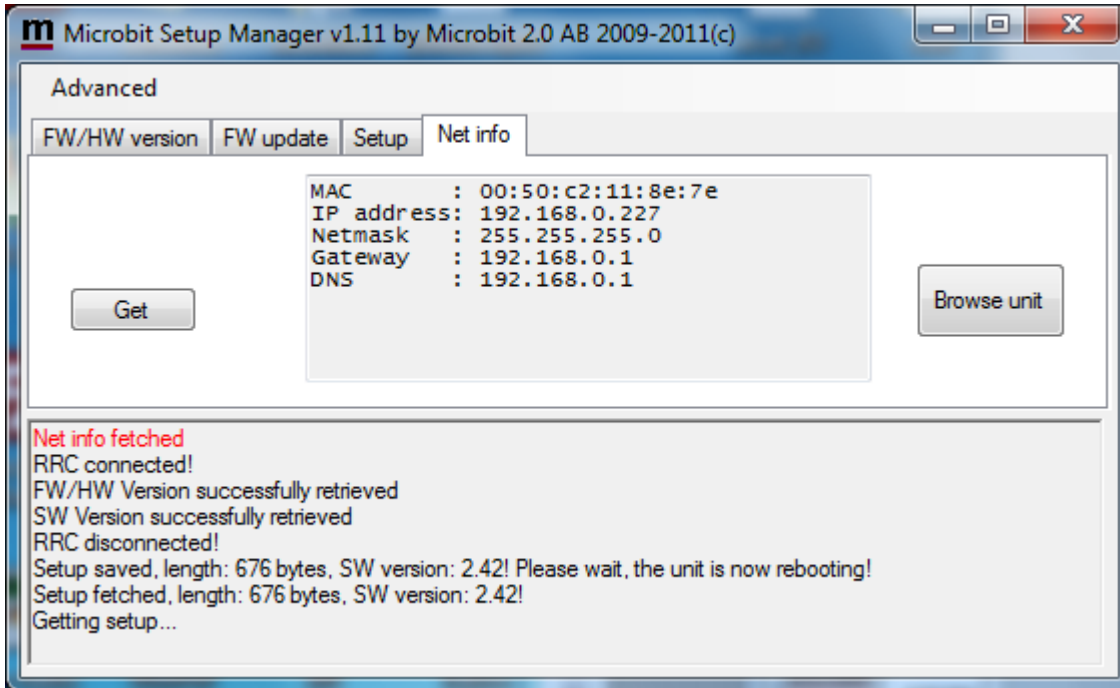

WiFi and Serial Port tabs

The Wifi tab is described in the WiFi Chapter. The Serial port tab is not used for the RRC-1258MkII it's used for other products.

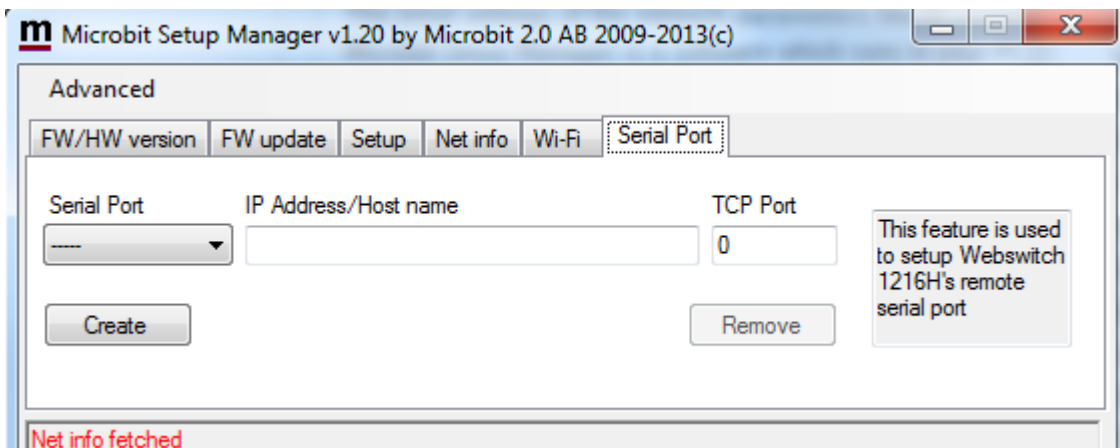

Initial IP setup

The default Ip settings from the factory is 192.168.0.227 (Control-RRC) and 192.168.0.228 (Radio-RRC). The net mask is 255.255.255.0. and the gateway 192.168.0.1.

To be able to contact the RRC-units via the network you must configure the units to fit into your home network. You can check your network configuration from your PC.

On the start menu select Run. In the Run dialog box enter cmd.

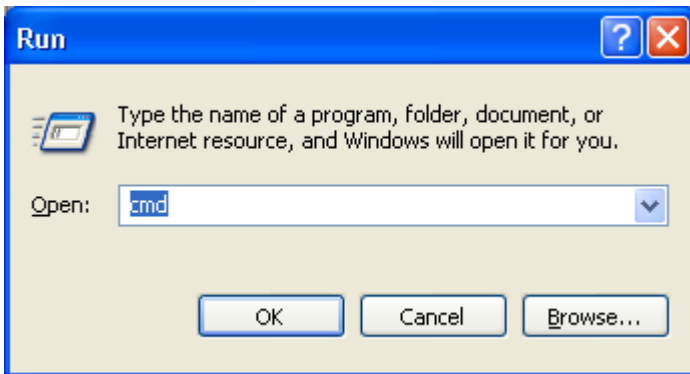

You will get a DOS-window.

At the DOS-prompt enter ipconfig.

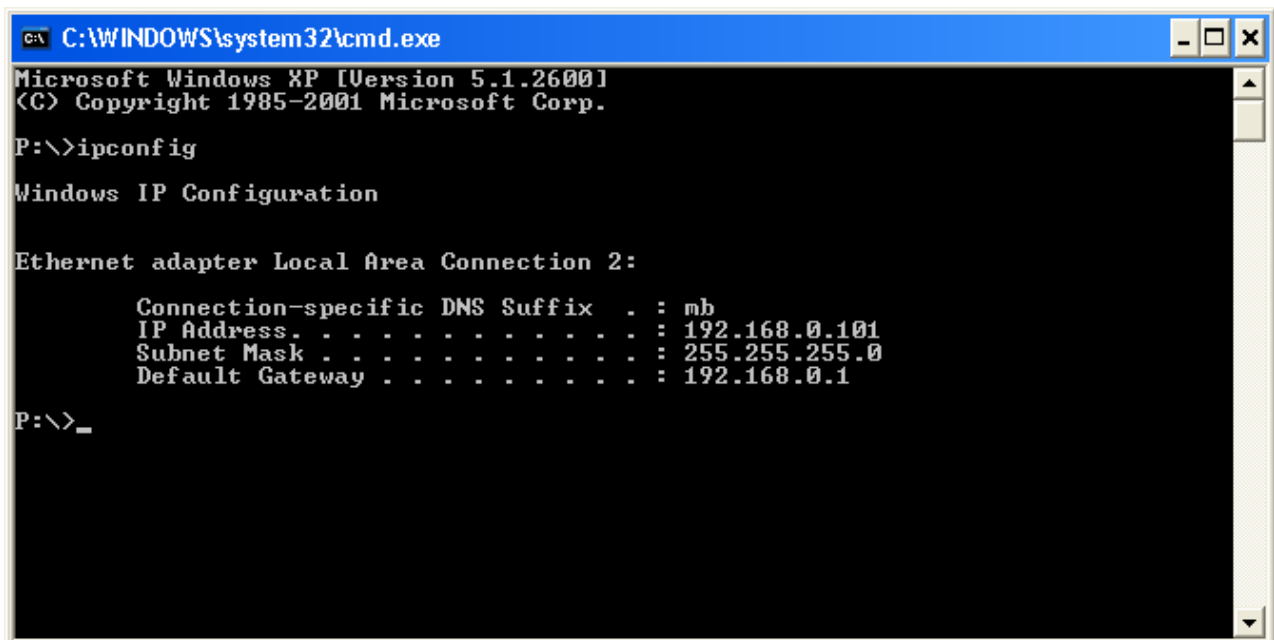

Then you will get the needed information:

Your PC IP address in this example is 192.168.0.101 this means that the IP of the RRC:s must have IP:s in the area 192.168.0.2 to 192.168.0.255.

The Netmask is 255.255.255.0 the Netmask in the RRC:s should be the same

The Default gateway is 192.168.0.1 the Gateway in the RRC:s should be the same

In this case all the default IP setting will be OK.

In an other network, this is the result of the ipconfig command.

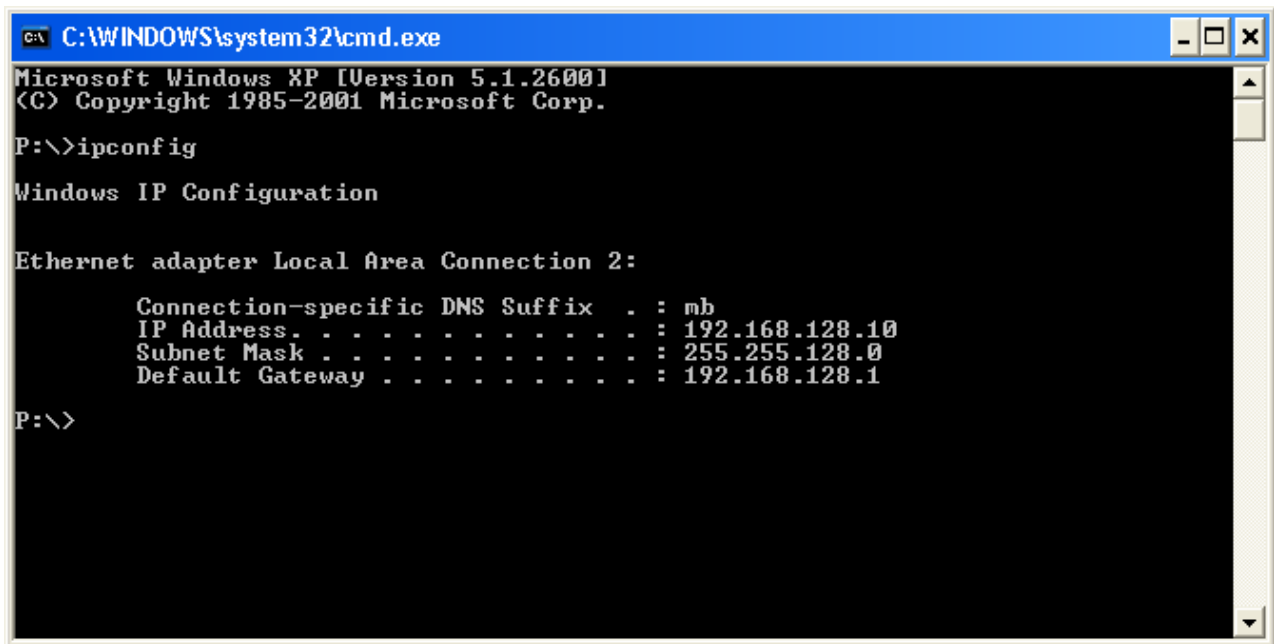

```
C:\WINDOWS\system32\cmd.exe
Microsoft Windows XP [Version 5.1.2600]
(C) Copyright 1985-2001 Microsoft Corp.

P:\>ipconfig

Windows IP Configuration

Ethernet adapter Local Area Connection 2:

    Connection-specific DNS Suffix  . : mb
    IP Address . . . . . : 192.168.128.10
    Subnet Mask . . . . . : 255.255.128.0
    Default Gateway . . . . . : 192.168.128.1

P:\>
```

Your PC IP address in this example is 192.168.128.10 this means that the IP of the RRC:s must have IP:s in the area 192.168.128.2 to 192.168.128.255.

The Netmask is 255.255.128.0 this the Netmask in the RRC:S should be the same

The Default gateway is 192.168.128.1 the Gateway and in the RRC:S should be the same

The DNS should in almost all situation be the same as Default gateway.

In this case you must change the IP:s of the RRC. I recommend to use 192.168.128.227 and 192.168.128.228

Use the Microbit Setup Manager to change the IP settings.

Select the Setup tab click on the "Get Setup" button and enter the IP addresses in the Setup info dialog box.

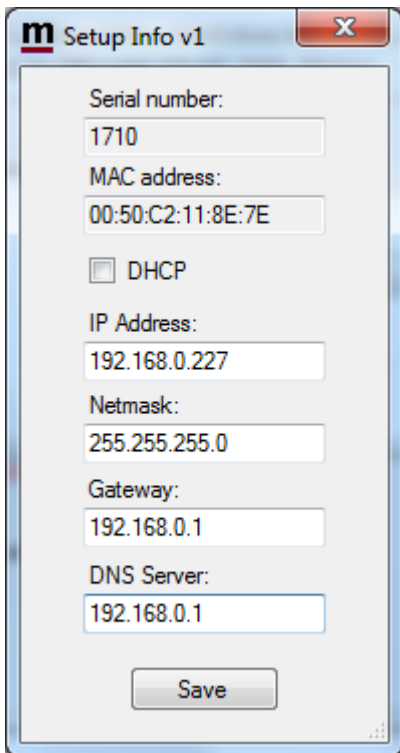

Configuration with WEB-interface

Before you can use your RRC-1258MkII you must configure both the hardware (strapping) and the software settings. The units will have the default IP addresses 192.168.0.227 (Control-RRC) and 192.168.0.228 (Radio-RRC). The net mask is 255.255.255.0. The configuration is easiest done via the web interface. Be aware of that your PC must be in the same net e.g. having an IP-number between 192.168.0.2 and 192.168.0.254 and not be the same as the RRC. If the default IP-addresses of the RRC not fit your network please use the PC-program Microbit Setup Manager to change the IP-addresses via LAN or USB. It's convenient to use DHCP at the Control-RRC but wait to active DHCP until everything is setup and working.

Select setup page from the links on the left side and edit the parameters. After each setup pages is finished press Submit to temporary store the new settings. When you do that a new red Apply changes button appears on the pages. You can now change parameters on other pages but the new settings will not take effect until you press Apply changes. When you do that the unit will reboot and start up with the new settings. If you change your mind after clicking on submit you can click on Restart device on the left to restart the device without changing any settings.



Info

The info page shows some static information about the RRC as firmware revision etc. and also the basic IP-configuration.

Name	Value
Company	Microbit
Product	1258
PID	4
Version	6
HW	7
Software	2.73
Bootloader	1.10
Compiler	4.6.2
Build	May 16 2013 16:01:09
ROM/RAM	449428/41868
ETH-RAM	2944 (max 3kB)
USB-RAM	15312 (max 16kB)
ResetSrc	0 [3]
Uptime	708
Serial number	5227
MAC address	00:1e:fd:01:8b:0b
IP address	192.168.139.10
Netmask	255.255.128.10
Gateway	192.168.128.1
DNS	192.168.128.1
Wi-Fi network	module not present

Status

On the status page you can check some parameters which can be useful when debugging etc. But the most important is that here is the "Connect" and "Disconnect" button used to connect or disconnect the Internet connection between the two RRC in some modes.

If the system is setup to be used with Control panels or Twins then there is no Connect/disconnect buttons, the connection is controlled by the power on switch on the control panel.

In some modes there are a disconnect button on the Radio-RRC status page which in a multi user system can be used to disconnect a user who have forgot to do it.

When connecting you will see how the SIP-status is changed to "Connected/Transferring" if everything is OK. Here is also shown how your NAT-router has mapped the ports and the momentary status of the inputs and outputs and some other things.

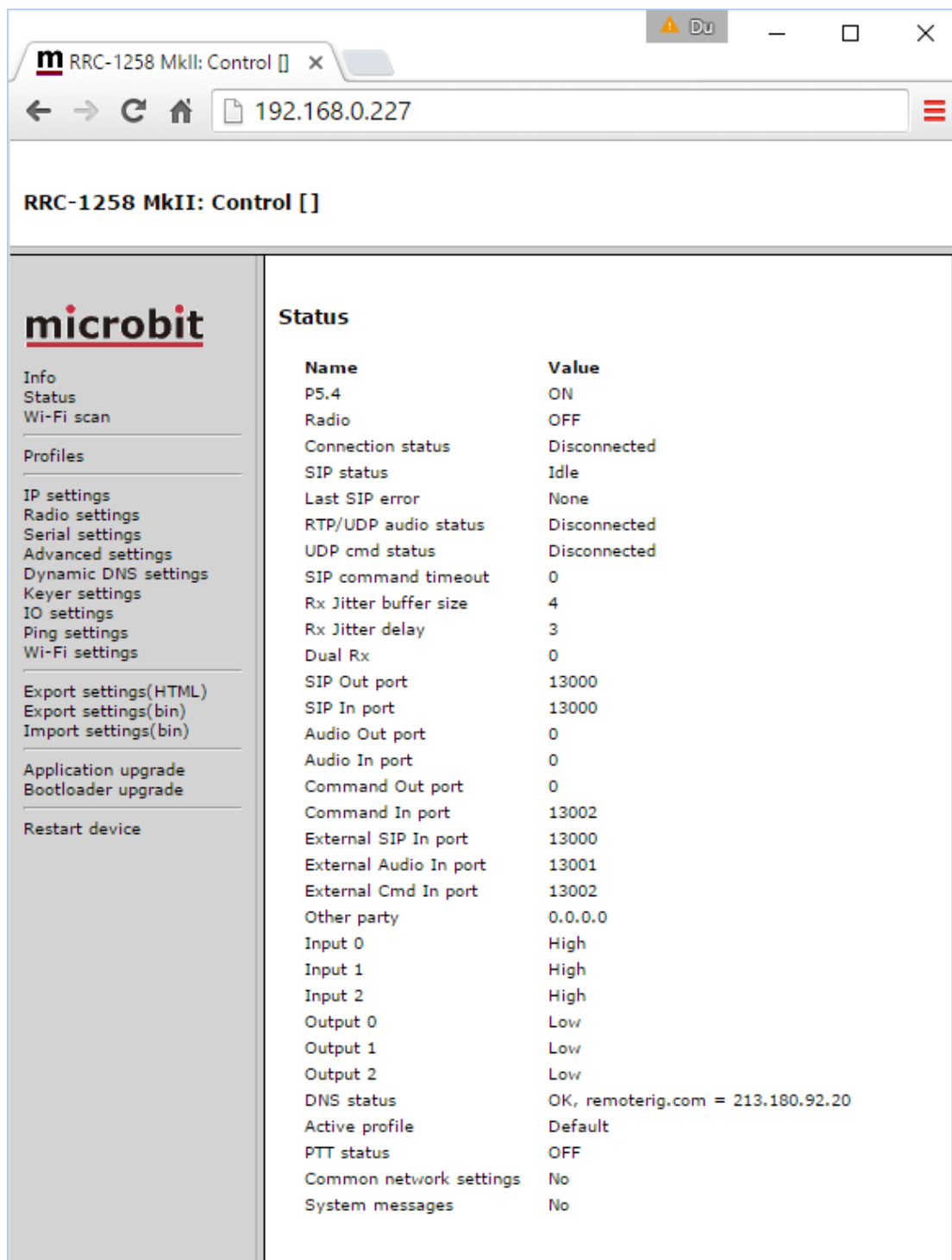

The screenshot shows a web browser window with the address bar set to 192.168.0.227. The page title is "RRC-1258 MkII: Control []". On the left side, there is a navigation menu with the "microbit" logo and several categories: Info (Status, Wi-Fi scan), Profiles, IP settings, Radio settings, Serial settings, Advanced settings, Dynamic DNS settings, Keyer settings, IO settings, Ping settings, Wi-Fi settings, Export settings (HTML, bin), Import settings (bin), Application upgrade, Bootloader upgrade, and Restart device. The main content area is titled "Status" and contains a table with two columns: "Name" and "Value".

Name	Value
P5.4	ON
Radio	OFF
Connection status	Disconnected
SIP status	Idle
Last SIP error	None
RTP/UDP audio status	Disconnected
UDP cmd status	Disconnected
SIP command timeout	0
Rx Jitter buffer size	4
Rx Jitter delay	3
Dual Rx	0
SIP Out port	13000
SIP In port	13000
Audio Out port	0
Audio In port	0
Command Out port	0
Command In port	13002
External SIP In port	13000
External Audio In port	13001
External Cmd In port	13002
Other party	0.0.0.0
Input 0	High
Input 1	High
Input 2	High
Output 0	Low
Output 1	Low
Output 2	Low
DNS status	OK, remoterig.com = 213.180.92.20
Active profile	Default
PTT status	OFF
Common network settings	No
System messages	No

Profiles

The profile menu is used to store and load settings profiles. This could be convenient if you change settings often. But **NO** settings are needed here if you do not use it, so leave this page to later if it's your initial setup of the RRC:s.

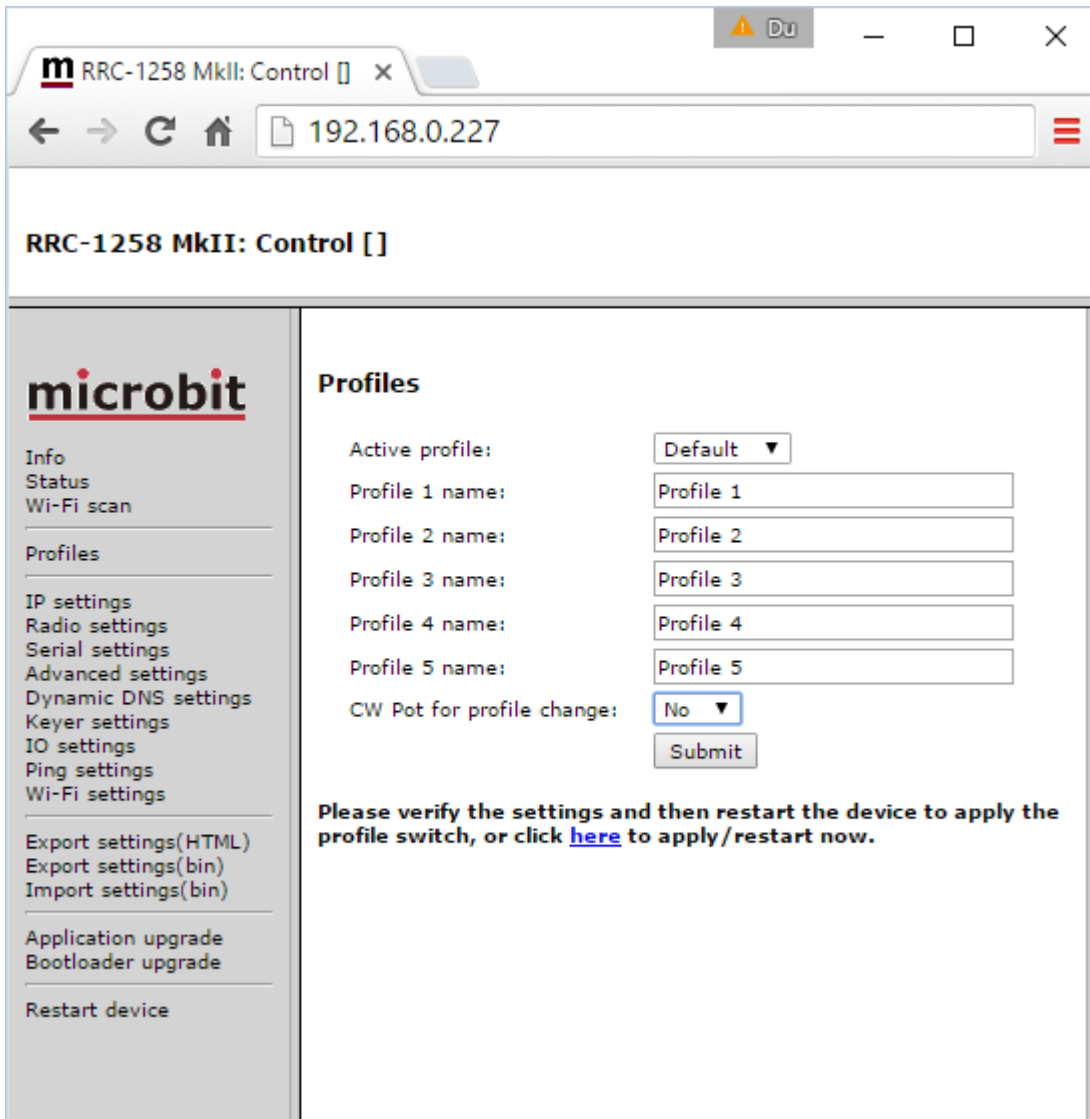

You can use up to five profiles and you can give them describing names.

The first time you activate another profile than the default profile the default profile will be copied to the other profiles.

When you save settings in the normal way with the red "apply settings" button the data will be saved in the profile which is active for the moment.

To change profile just select "Active profile" to the profile you want to change to, and press submit. The new profile will then be loaded but will not be used before restart so you can check all settings and the restart to make the new profile active.

Changing Profile with Microbit Setup Manager

Profiles can also be changed from the Setup Manager which can be useful if you connected it to different networks.

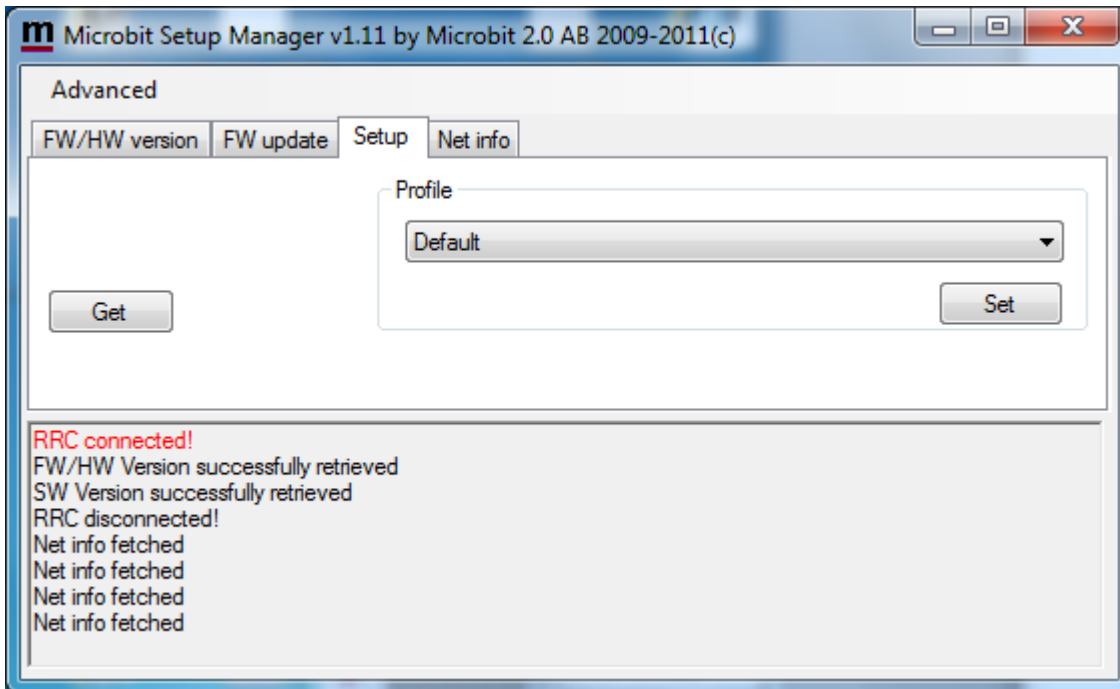

Changing Profile with the CW-pot

A special feature is available where you can use the CW-pot on the front to change profile. This feature has been requested by users who change profile often and do not want to have a PC available. To use this feature change the setting "CW-pot for profile change" to Yes.

The 3 front LEDs (PWR, AUX/MIC LEDs) will show the current profile after startup (applying power or pressing the reset button) by a flashing pattern. Just turn the CW pot in any direction within 7 seconds while the LEDs are flashing to start the profile change. The LEDs will then stop flashing the current profile and start showing the new profile. When the desired profile has been set stop turning the CW pot and the RRC will restart itself after 7 seconds to apply the selected profile. To confirm the chosen profile was set the RRC will repeat the flashing pattern, just wait 7 seconds and the RRC will be running.

This is the pattern used by the 3 LEDs from left to right with X=lit:

Profile	Pwr LED (Green)	Aux/Mic (Red)	Aux/Mic (Yellow)
Default			x
1		x	
2		x	x
3	x		x
4	x	x	
5	x	x	x

Note that you will have to adjust the CW pot again when the RRC is running if you are using it to set the CW speed.

IP Settings

The IP Settings menu is used to setup the initial IP parameters needed for the unit to connect to the IP network. Down below the settings are described more in details.

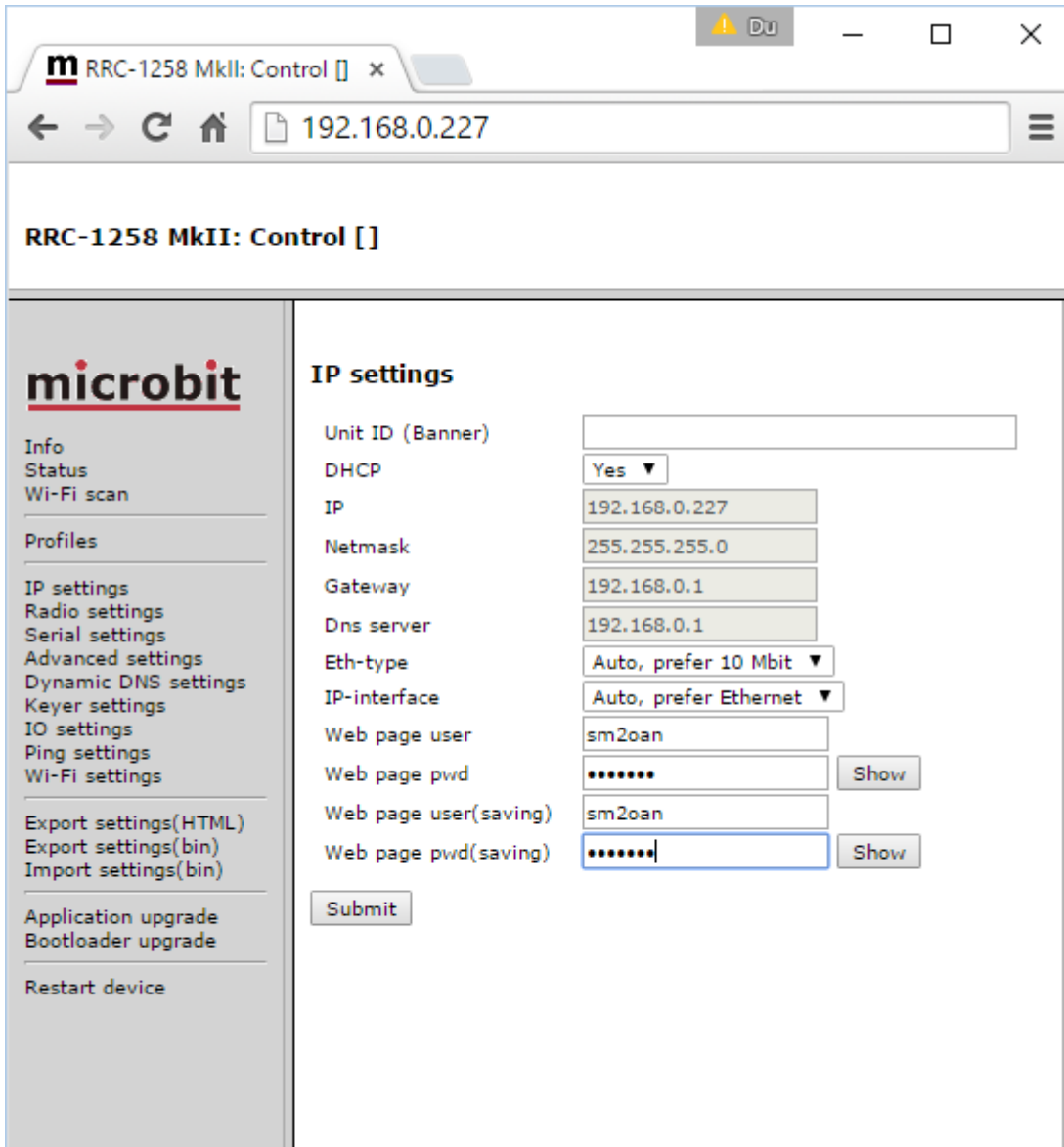

Parameter	Setting
Unit ID (Banner)	Text, whatever you want, that will be shown at the top of the web-page (within brackets). Used to identify different RRC. "empty" (default) "text"
DHCP	Select between a fixed IP address and DHCP. DHCP can be practical for the Control-RRC but fixed IP address is preferred in Radio-RRC. No (default) Yes
IP	IP-address (only when fixed IP-address is used) 192.168.0.227 (default Control-RRC) 192.168.0.228 (default Radio-RRC) nnn.nnn.nnn.nnn
Netmask	Net mask (only when fixed IP-address is used) 255.255.255.0 (default) nnn.nnn.nnn.nnn
Gateway	Gateway (only when fixed IP-address is used) 192.168.0.1 (default) nnn.nnn.nnn.nnn
Dns server	DNS-address (only when fixed IP-address is used) 192.168.0.1 (default) nnn.nnn.nnn.nnn
Extern IP/Host	Fixed external IP-address of your NAT-router. Should NOT be used in normal installations. "empty" (default) nnn.nnn.nnn.nnn
Eth-type	Type of Ethernet connection: Auto Auto, prefer 10 Mbit (default) 10HDX* 10FDX* 100HDX* 100FDX* Auto prefer 10 Mbit is default as more speed is not needed and the emissions from a 10 Mbit LAN is much less than from a 100 Mbit LAN (*) If you use fixed settings you must have a managed switch where you can set the same setting.

IP-interface	<p>Normally the RRC connects via the Ethernet interface if it's available, and as second choice via the WiFi. If you set it to "Ethernet" you can force the RRC not to connect via WiFi even if the Ethernet is not available for the moment.</p> <p>"Auto, prefer Ethernet" (default) "Ethernet"</p>
Web page user	<p>Enable password protection for the web pages and also the telnet connection by entering a username (this field) and a password (next field). If this field is empty the RRC will not ask for password. Some of the pages are still accessible but no editing is possible.</p> <p>"empty" (default) "username"</p>
Web page pwd	<p>Password for the web pages and telnet connection. The password are shown as **** to view it click on the "show" button"</p> <p>"empty" (default) "password"</p>
Web page user (saving)	<p>The saving user and password settings can be used if you only want to protect the pages from unauthorized savings or if you are several user who need to see the web pages but only one are allowed to change the settings.</p> <p>"empty" (default) "username"</p>
Web page pwd (saving)	<p>Password for saving settings. The password are shown as **** to view it click on the "show" button"</p> <p>"empty" (default) "password"</p>

Radio Settings

The Radio settings are used to setup the RRC to act together with different radios. The settings must be done in both Control-RRC and Radio-RRC and the parameters are partly different for the both RRC.

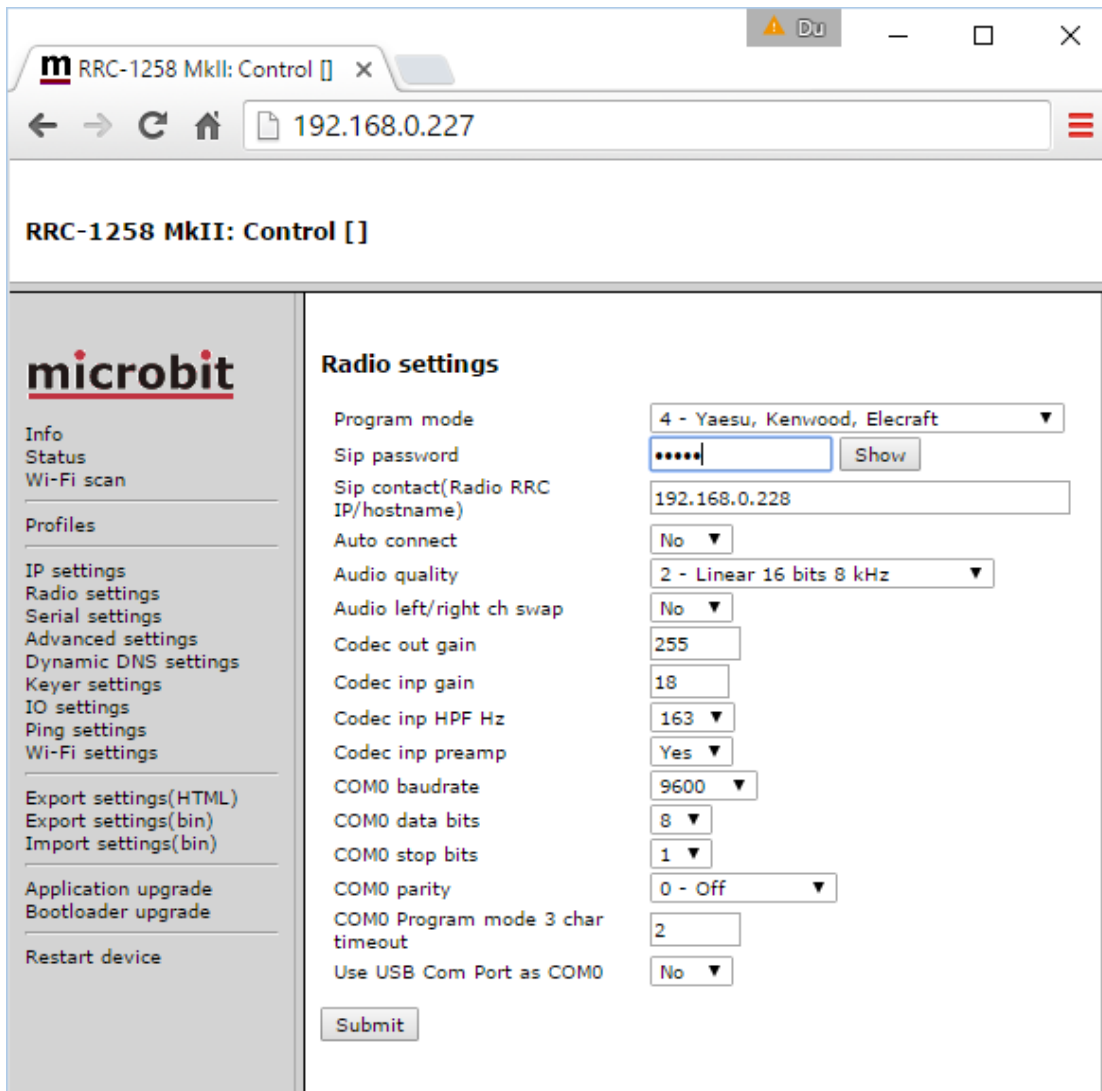

microbit

Info
Status
Wi-Fi scan

Profiles

IP settings
Radio settings
Serial settings
Advanced settings
Dynamic DNS settings
Keyer settings
IO settings
Ping settings
Wi-Fi settings

Export settings(HTML)
Export settings(bin)
Import settings(bin)

Application upgrade
Bootloader upgrade

Restart device

Radio settings

Program mode: 4 - Yaesu, Kenwood, Elecraft

Sip password: Show

Audio quality: 2 - Linear 16 bits 8 kHz

Audio dual-rx: No

Codec out gain: 255

Codec inp gain: 0

Codec inp HPF Hz: 163

Codec inp attenuation: No

COM0 baudrate: 9600

COM0 data bits: 8

COM0 stop bits: 1

COM0 parity: 0 - Off

COM0 Program mode 3 char timeout: 2

Submit

Parameter	Setting
Program mode	<p>Select the program mode depending on connected radio:</p> <ul style="list-style-type: none"> 0 = Transparent (for repeater links etc.) 1 = ICOM CI-V (generic) 2 = IC706 (with detached control panel) 3 = FT-8x7, FT-1000 (generic) 4 = Kenwood, Yaesu, Elecraft 5 = TS480/TM-D710 (with detached control panel) 6 = (*1) 7 = IC-R2500/IC-2725(with detached control panel) 8 = TS-2000/TM-D700 (TS-2000 with RC-2000) 9 = IC-2820 (with detached control panel) 10 = Yeasu FT-950/FT-2K/FT-5K/FT-9K- Twin 11 = Transparent, 4-wire (for repeater links etc.) 12 = DX-SR8 (with detached control panel) 13 = ID-E880(with detached control panel) 14 = K3 twin 15 = Yaesu FT-857 (with detached control panel) 16 = Yaesu FT-100 (with detached control panel) 17 = Yaseu FTM-350 (with detached control panel) <p>(*1) These selections are only possible in special editions of the RRC.</p>
Sip password	<p>Protect your remote rig and should be same in both ends. Normally shown as **** click on the "show" button to view the password. (default: no password)</p>
Sip contact	<p>Control-RRC: Sets the fixed IP address or the Dynamic DNS "own host name" to the Radio-RRC</p>
Auto connect	<p>Control-RRC: When enabled the Control-RRC will connect to Radio-RRC immediately after power up in program mode 0, 1, 3 and 4. No (default) Yes</p>

<p>Audio quality</p>	<p>Sets the audio quality depending on available bandwidth. Sample rate must be same in both RRC but coding can be different (more information can be found in appendix-A Audio coding):</p> <ul style="list-style-type: none"> 0 = A-law 8 kHz 1 = Linear 12 bits 8 kHz 2 = Linear 16 bits 8 kHz (default) 3 = A-law 12 kHz 4 = Linear 12 bits 12 kHz 5 = Linear 16 bits 12 kHz 6 = A-law 16 kHz 7 = Linear 12 bits 16 kHz 8 = Linear 16 bits 16 kHz 9 = A-law 24 kHz 10 = Linear 12 bits 24 kHz 11 = Linear 16 bits 24 kHz 12 = IMA ADPCM 4 bits 8 kHz 12 = IMA ADPCM 4 bits 16 kHz
<p>Audio Dual-RX</p>	<p>Sets if LF from the Sub-RX should be sent as an separate audio channel. Be aware of that this doubles the need of Bandwidth. (Only available in the (s) version.)</p>
<p>Codec out gain</p>	<p>Sets the attenuation for the audio output, in 255 steps and 0.5 dB per step. Should always be set to 255.</p> <ul style="list-style-type: none"> 255 = no attenuation (default) 254 = -0.5 dB 253 = -1.0 dB ... 0 = max attenuation
<p>Codec inp gain</p>	<p>Sets the gain for the audio input in 63 steps and 0.75 dB per step. Should be 18 at Control-RRC for high level electret microphones and should always be 0 at Radio-RRC.</p> <ul style="list-style-type: none"> 0 = default Radio-RRC ... 18 = default Control-RRC ... 63 = max value

Codec inp HPF Hz	<p>Sets the low cut frequency for the audio passband [Hz]:</p> <p>82 102 131 163 (default) 204 261 327 408</p> <p>The upper cut frequency is set automatically depending on the sampling rate.</p>
Codec inp preamp	<p>Control-RRC:</p> <p>Enables a +20 dB pre-amplifier for the audio input at the Control-RRC:</p> <p>No Yes (default)</p>
Codec inp attenuation	<p>Radio-RRC:</p> <p>Enables a -20 dB attenuator to the speaker input at the Radio-RRC:</p> <p>No (default) Yes</p>
COM0 baudrate	<p>Set COM0 baudrate for the radio communication [bps]:</p> <p>600 1200 2400 4800 9600 (IC-R2500,IC-2725) 19200 (IC703/706) 38400 (IC2820,DX-SR8,ID-E880) 48000 (FTM-350) 57600 (TS480, TS2000) 64000 (FT-857, FT-100)</p>
COM0 data bits	<p>Set COM0 data bits:</p> <p>5 6 7 8 (default)</p>
COM0 stop bits	<p>Set COM0 stop bits:</p> <p>1 (default) 2</p>
COM0 parity	<p>Set COM0 parity:</p> <p>0 = Off (default) 1 = Odd 2 = Even 3 = Forced-1 4 = Forced-0</p>

COM0 Program mode 3 char timeout	The char timeout can be programmed. The default timeout should be 2 and works for all radios except FT-1000 in 4800 baud which need it to be set to 60. 2 = default 60 = FT-1000 in 4800 baud
Use USB Com Port as COM0	COM0 can be connected to the USB interface instead of the normal serial interface. When installing Microbit Setup manager a virtual Com port called "Microbit RRC Virtual Comport (COMX)" is installed. That's the one you should connect to when using HRD or other softwares. Yes or No (default = No).

Serial Settings

The serial ports COM1 and COM2 can be used as a transparent serial channel between Control-RRC and Radio-RRC over Internet. The COM-ports can be used for CAT control, rotator control etc. COM1 is always free to be used with the drawback that you cannot use COM1 for configuration. COM2 is used for the radio control in some of the program modes and can then not be used as a transparent serial channel. There is also a COM3 which is only available via USB and only for WinKey and RTTY.

Radio settings / Program mode	COM1 free channel	COM2 free channel
0 - Transparent	yes	yes
1 - ICOM CI-V	yes	no
2 - IC-7100,IC-706,IC-703	yes	yes
3 - FT-8x7, FT-1000x	yes	no
4 - Yaesu, Kenwood, Elecraft	yes	no
5 - TS480/TM-D710	yes	yes
6 - (*)	yes	yes
7 - IC-R2500/IC-2725(*1)	yes	yes
8 - TS2000/TM-D700	yes	yes
9 - IC-2820	yes	yes
10 - Yaeasu FT-450/FT-950/FT-2000/FT-5000/FT-9000 Twin	yes	no
11 - Transparent, 2/4-wire(*1)	yes	yes
12 - DX-SR8	yes	yes
13 - ID-E880 (*1)	yes	yes
14 - Elecraft K3-Twin	yes	no
15 - Yaesu FT-857	yes	yes
16 - FT-100	yes	yes
17 - FTM-350	yes	yes

COM1 and COM2 mode can be configured differently depending on what they will be used for. The same settings must be done in both Control-RRC and Radio-RRC.

(*1) = Need special hardware

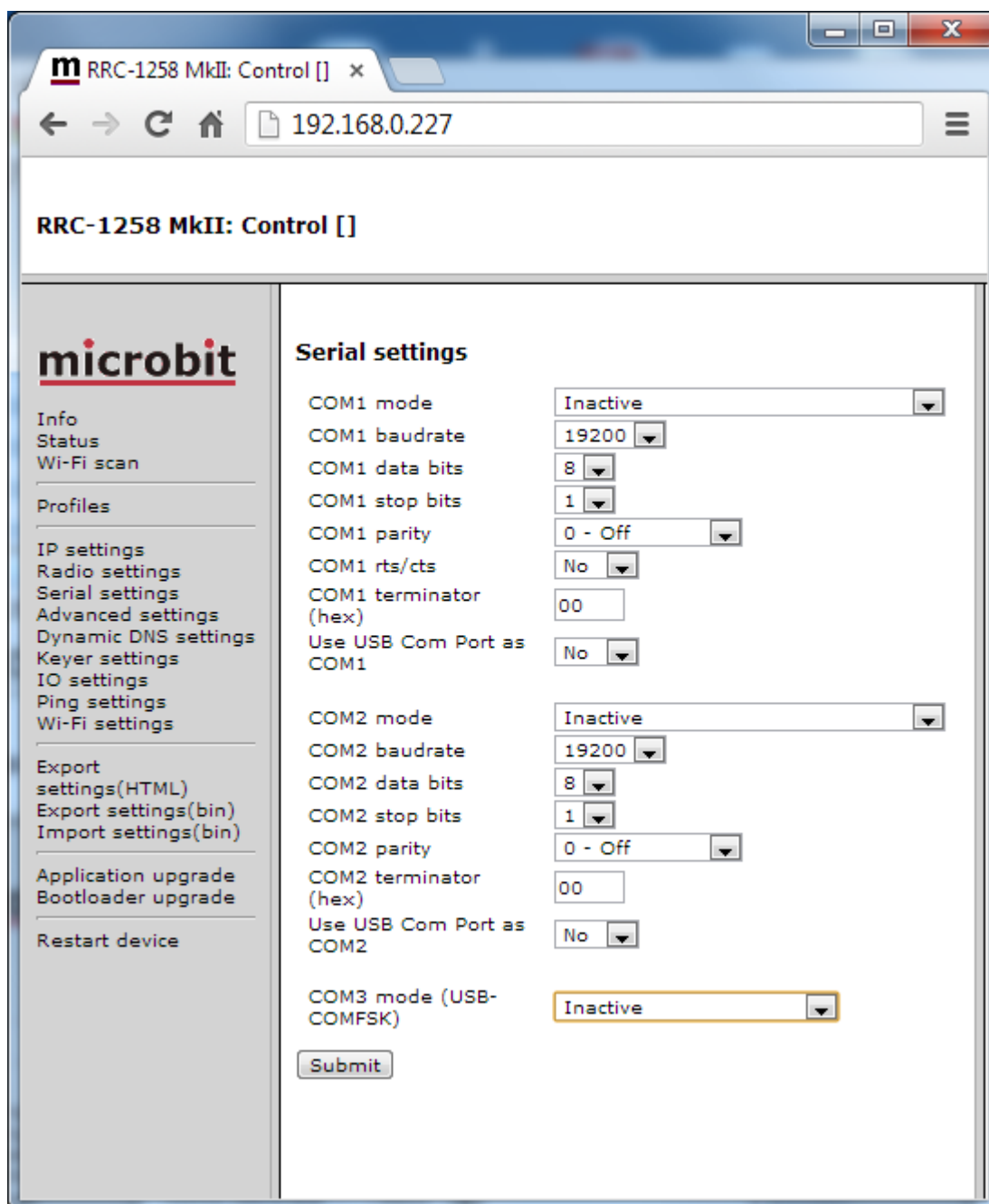

Parameter	Setting
COM1 mode	<p>Select mode for COM1-to-COM1 transparent transfer of serial data between two opposite RRC. The setting defines the event that triggers the data transfer over Internet.</p> <p>Inactive (default)</p> <p>Mode 1 = Char-by-char. A data packet is send for each char, needs lot of bandwidth.</p> <p>Mode 2 = ICOM CI-V. Used for CI-V control of IC-703/706 at the same time as you use the control panel.</p> <p>Mode 3 = Char-timeout. A data packet is sent when there is a pre-defined pause between two received char.</p> <p>Mode 4 = Kenwood, Yaesu, Elecraft. Used for CAT control of TS-480 or TS-2000 at the same time as you use the control panel.</p> <p>Mode 5 = User-def-terminator. Used if you want to define the terminator char by yourself (see below). Should be activated together with Mode-7 in Radio-RRC to combine data from COM1 with the other ports described above.</p>

	<p>Mode 6 = CAT to COM2 local (Control-RRC) makes it possible to connect for example a logger PC which needs to speak to the Control radio to COM1 at the Radio-RRC. The IP-data from radio side COM2 and this local COM1 will be intelligent mixed (in sequence) before sent to local COM2. Data from local COM2 goes to both local COM1 and to the radio side COM2 via IP. This function is only for the Yaesu Twin configuration only.</p> <p>Mode 6 = CAT to COM2 local (Radio-RRC) makes it possible to connect other hardware which needs to speak to the radio via COM1 at the Radio-RRC. The IP-data from control side COM2 and local COM1 will be intelligent mixed (in sequence) before sent to local COM2. Data from local COM2 goes to both local COM1 and to the control side COM2 via IP. Can be used for MicroHam, the Web-Switch, Power Amplifier etc. This function is for Yaesu, Kenwood and Elecraft only.</p> <p>Mode 7 = CAT to COM2 local & remote (Radio-RRC) Same function as above but it also combines data sent from COM1 in Control-RRC with data from the local COM1 and Control-RRC COM2. (Remember that this function doubles the data amount sent over the Internet).</p> <p>Mode 7 = CAT to COM2 remote (Control-RRC) Is used in combination with mode 7 at the Radio-RRC.</p> <p>Mode 8 = The WinKeyer emulator is activated, and data received from COM1 are sent as CW from the Radio-RRC in parallel with the ordinary keyer.</p>
COM1 baudrate	<p>Set COM1 baudrate [bps]:</p> <p>600 1200 2400 4800 9600 (default) 19200 38400 48000 57600</p>
COM1 databits	<p>Set COM1 data bits:</p> <p>5 6 7 8 (default)</p>

COM1 stop bits	Set COM1 stop bits: 1 (default) 2
COM1 parity	Set COM1 parity: 0 = Off (default) 1 = Odd 2 = Even 3 = Forced-1 4 = Forced-0
COM1 cts/rts	Enable the transfer of CTS input to RTS output of other RRC. 0 = No (default) 1 = Yes
COM1 terminator	Defines the terminator character used in COM1-mode=5 (user-def-terminator). Character should be in HEX-format. 00 (default)
Use USB Com Port as COM1	COM1 can be connected to the USB interface instead of the RS-232 interface if your PC do not have traditional com ports. When installing Microbit Setup manager a virtual Com port called "Microbit RRC Virtual Comport (COMX)" is installed. That's the one you should connect to when using HRD or other softwares. Yes or No (default = No).

COM2 mode	<p>Select mode for COM2-to-COM2 transparent transfer of serial data between two opposite RRC. The setting defines the event that triggers the data transfer over Internet.</p> <p>Inactive (default) Logical parallel with COM0. = Is used for level converting for CI-V and FT-8x7. The settings from "Radio settings" are used.</p> <p>Mode 1 = Char-by-char. A data packet is send for each char, needs lot of bandwidth.</p> <p>Mode 2 = ICOM CI-V. Used for CI-V control of IC-703/706 at the same time as you use the control panel.</p> <p>Mode 3 = Char-timeout. A data packet is sent when there is a pre-defined pause between two received char.</p> <p>Mode 4 = Kenwood, Yaesu, Elecraft. Used for CAT control of TS-480 or TS-2000 at the same time as you use the control panel.</p> <p>Mode 5 = User-def-terminator. Used if you want to define the terminator char by yourself (see below).</p> <p>Mode 8 = The WinKeyer emulator is activated, and data received from COM1 are sent as CW from the Radio-RRC in parallel with the ordinary keyer.</p>
COM2 databits	See COM1
COM2 stop bits	See COM1
COM2 parity	See COM1
COM2 terminator	See COM1
Use USB Com Port as COM2	<p>COM2 can be connected to the USB interface instead of the RS-232 interface if your PC do not have traditional com ports. When installing Microbit Setup manager a virtual Com port called "Microbit RRC Virtual Comport (COMX)" is installed. That's the one you should connect to when using HRD or other softwares.</p> <p>Yes or No (default = No).</p>
<p>COM3 mode (COMExtra)</p> <p><i>Only available in the Control-RRC</i></p>	<p>COM3 is available only via USB. It's shown as COMExtra in Widows Device manager. In mode-8 the WinKeyer emulator is activated, and data received from the USB port are sent as CW from the Radio-RRC in parallel with the ordinary keyer. In mode-10 received data from the USB port RTTY are sent by the Radio-RRC via one of the (selectable) outputs.</p> <p>"Inactive" (default) "Mode-8 WinKeyer" "Mode-10 Baudot RTTY"</p>

Advanced settings

Under advanced settings it is possible to change the default port numbers used by the RRC. It can be necessary if there are more than one RRC on your LAN. In earlier versions we used port 5060 for SIP but it's often reserved for IP-telephony today so we have changed default ports. You really need to know what you are doing when you change port numbers especially on the Radio-RRC so that you don't disconnect yourself. Change web and telnet port number ONLY if you have to due to other services or more than one RRC on your LAN. If you lose the connection a car ride might be the next thing you do.

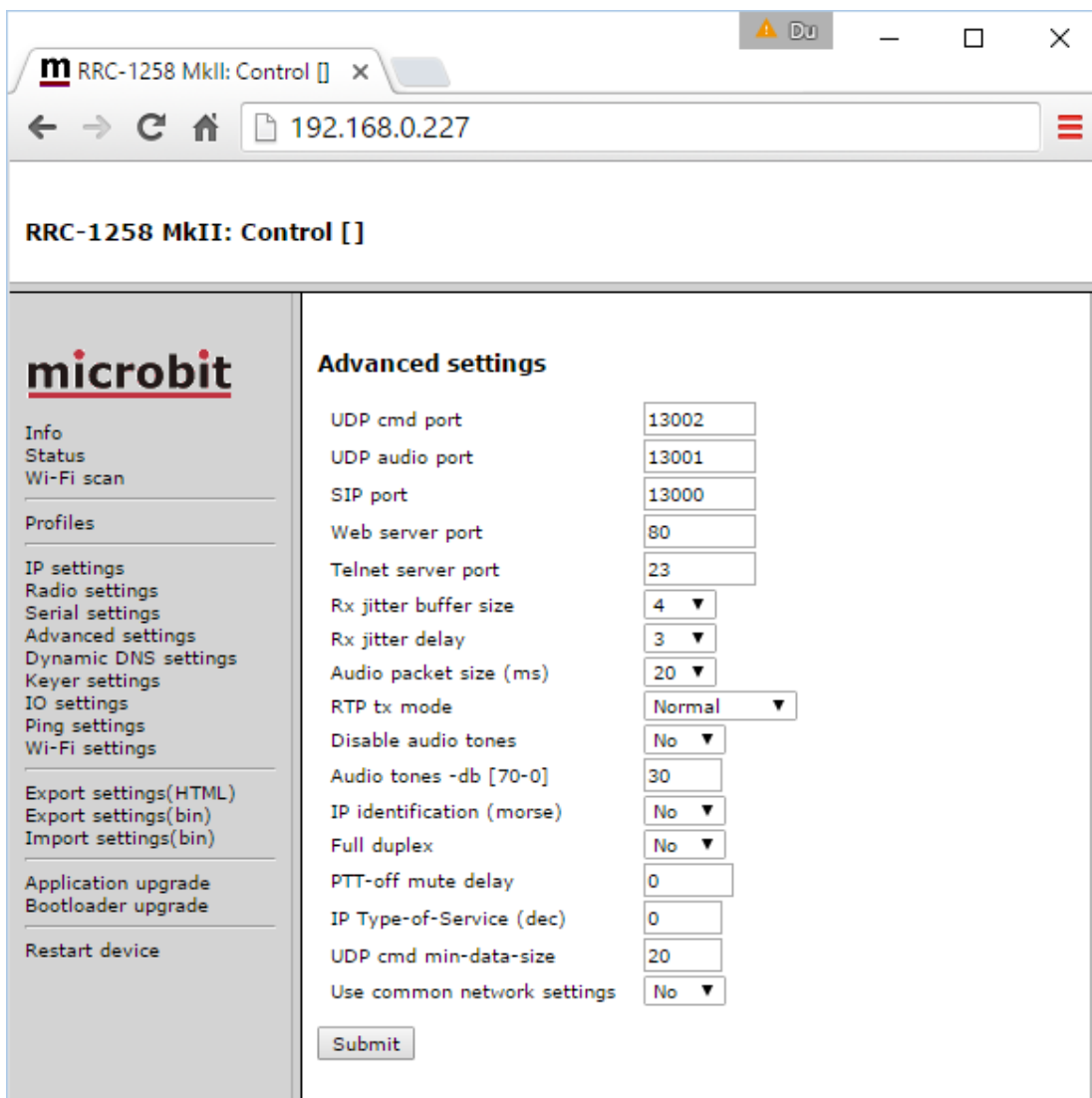

The screenshot shows a web browser window with the address bar set to 192.168.0.227. The page title is "RRC-1258 MkII: Control []". The main content area is titled "Advanced settings" and contains the following configuration options:

UDP cmd port	13002
UDP audio port	13001
SIP port	13000
Web server port	80
Telnet server port	23
Rx jitter buffer size	4 ▼
Rx jitter delay	3 ▼
Audio packet size (ms)	20 ▼
RTP tx mode	Normal ▼
Disable audio tones	No ▼
Audio tones -db [70-0]	30
IP identification (morse)	No ▼
Full duplex	No ▼
PTT-off mute delay	0
IP Type-of-Service (dec)	0
UDP cmd min-data-size	20
Use common network settings	No ▼

A "Submit" button is located at the bottom of the settings list.

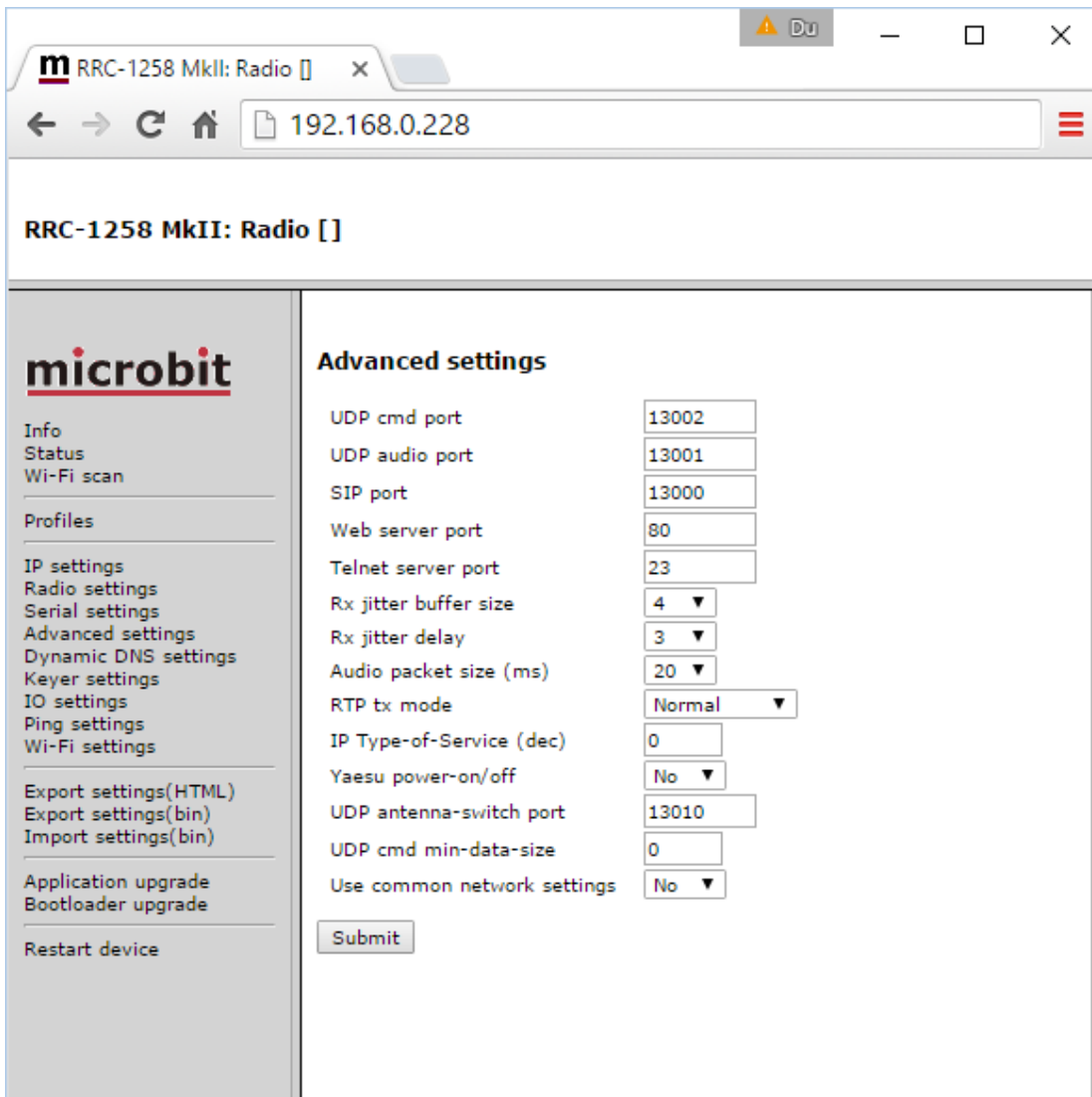

Parameter	Setting
UDP cmd port	Port number used for the Command channel. 13002 (default)
UDP audio port	Port number used for the audio channel 13001 (default)
SIP port	Port number used for the SIP session. 13000 (default)
Web server port	Port number used for the internal http web server. 80 (default)
Telnet server port	Port number used for the internal telnet server. 23 (default)

Rx jitter buffer size	Set the maximum number of audio packets from the received audio stream that is buffered. Dictates maximum playback delay. Higher values result in better tolerance against bad Internet connections. Note that this value must be larger than the jitter delay. 4 (default)
Rx jitter delay	Set the number of audio packets received and buffered from the audio stream before beginning playback. Dictates minimum playback delay. Small values gives short delays, higher values result in better tolerance against bad Internet connections but the delay will increase. Note that this value must be less than the jitter buffer size. 3 (default)
Audio packet size (ms)	Sets the max size (length) of the audio packets in ms. If you have a good Internet connection with lots of bandwidth or running both RRC:s under the same LAN/WLAN it's possible to reduce the packet size down to 1 ms. Smaller packets means decreased delay but increased bandwidth. 20 (default)
RTP Tx Mode	<u>Control-RRC</u> : If VOX will be used switch on this function. It means that the audio stream is sent continuously from the Control-RRC to the Radio-RRC. This can be a security problem for some user because the audio from the mic is sent to the Internet all the time. <u>Radio-RRC</u> : Some mobile (3G) networks have a delay before they open up for the audio stream which ends up in problems when releasing the PTT. This function often solves this problem. If you use a Squelched radio you can set "RTP tx mode" to Squelched, the audio data will then only be sent when the squelch is open to reduce cost if you pay by Mb for example. Normal (default) Continuous Squelch (Only radio-RRC)
Disable Audio tones (Control-RRC only).	Makes it possible to disable the Busy and Error tones. No (default) Yes
Audio tones-dB [70-0] (Control-RRC only)	You can set the level of the different status tones generated by the RRC 70-0 30 (default)
IP identification (morse) (Control-RRC only)	Makes it possible to let the Control-RRC to send it's IP number in morse code, can be useful when DHCP is used. No (default) Yes

Full Duplex (Control-RRC only)	Makes it possible to use full duplex. Eg. the speaker will not be muted when PTT is pressed. To use the function "Continuous RTP Tx" must be activated in the Radio-RRC. No (default) Yes
Yaesu pwr-on/off (Radio-RRC only)	Is used to switch on and off Yaesu FT-450/950/2000/5000/9000radios automatically on connect/disconnect when radiomode 4 or 10 is used. No (default) Yes
PTT-off mute delay (Control-RRC only)	Makes it possible to mute chirps coming from Tx-monitor audio when PTT is released. 0-999 (0 = default)
IP Type-of-Service (dec)	The RTP packets can be tagged for ToS according to RFC 791 to make it possible to use QoS in networks which support QoS. The parameter is entered in decimal. 0 (default)
UDP antenna-switch port (Radio-RRC only)	Sets the port to which the Remoterig 10 x Antenna switch should connect to, Should match the settings in the antenna switch. 13010 (default)
UDP cmd min-data- size	In some very rare situations routers/ISP will not transfer very short UDP messages. In this situations you can set the min data size of the message. The message is filled out with dummy data. 0-100 0 (default)
Use common network settings	No (default) Yes

Dynamic DNS setting (only Radio-RRC)

The Radio-RRC has a Dynamic DNS client to be used when the Internet Service Provider (ISP) uses dynamic IP addresses (DHCP) instead of fixed IP address. DHCP is the most common for private users. The RRC supports our own **free Remoterig dynamic DNS service** and DynDNS which is not free for new users anymore. You can choose to use one of them. The advantage with using a dynamic DNS service is that you do not need to know the IP address to your remote router, you only need to remember the own host name. The Radio-RRC will automatically update the DNS server when the IP changes so you don't need to bother about it.

Remoterig dynamic dns service

The Remoterig dynamic dns service only support equipment from Remoterig and Microbit like the RRC-1258 and the WebSwitch 1216H etc.

The Remoterig dynamic dns service do not need any registration it's automatically generated based on the serial number on the equipment.

To activate the Remoterig dynamic dns client select "ddns.remoterig.com" from the drop down on the Dynamic DNS settings page. Also select a DNS check interval, if your IP address change often you can select a low value, if it goes month between the changes you can select a higher value. After that click on "Submit" and "Apply changes", the RRC will restart.

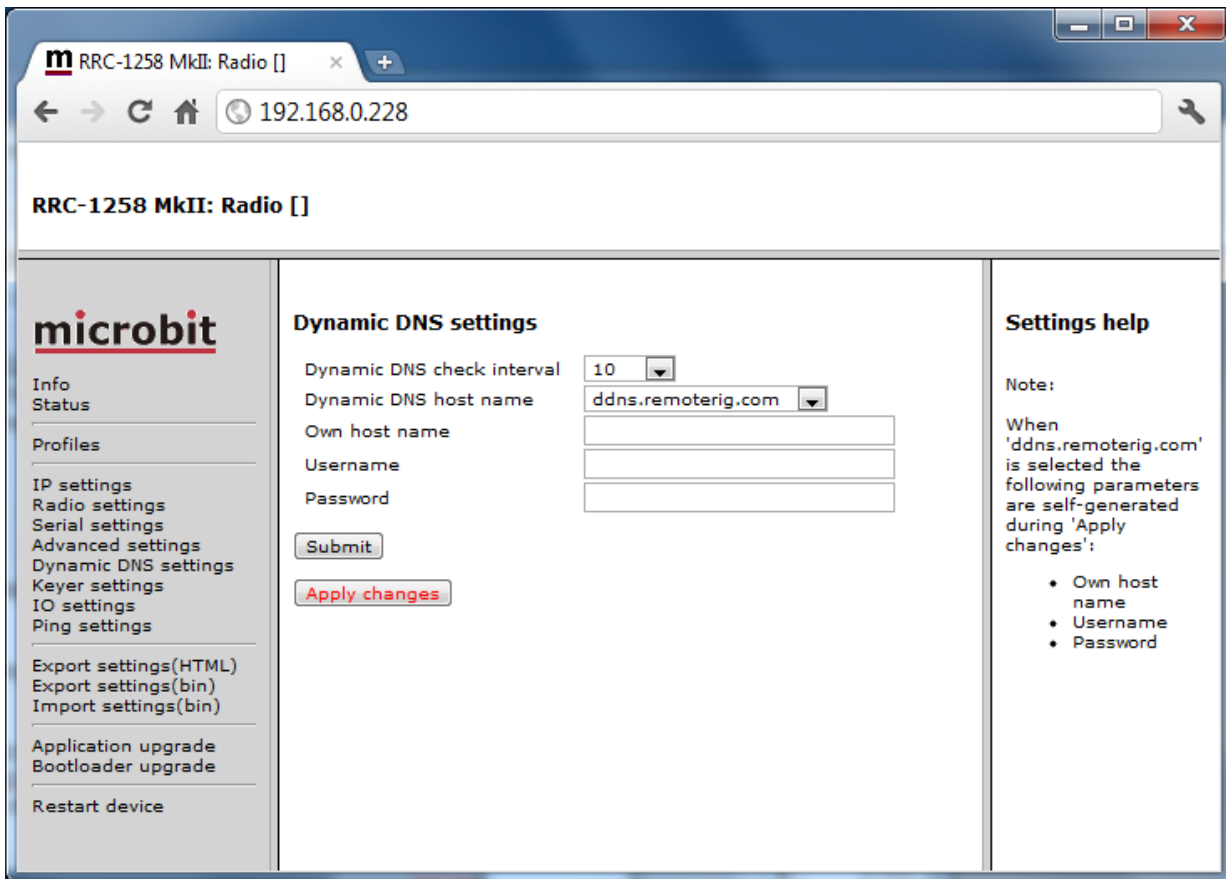

After the RRC has restarted go back to the Dynamic DNS settings page. You will now see that the settings Own hostname, Username and Password are automatically generated. The only important information is the Own hostname, copy the whole row, this is the information you should put into the SIP contact box in the Control-RRC and the web address you should use when remote configure the Radio-RRC in the future. No more registration is needed. Remember that DNS address like this is only for use when you connect over the internet, as long as you are operating on you own LAN use the IP address. When using ddns it's important that the DNS settings are ok as they are needed for the RRC to be able to update the ddns.

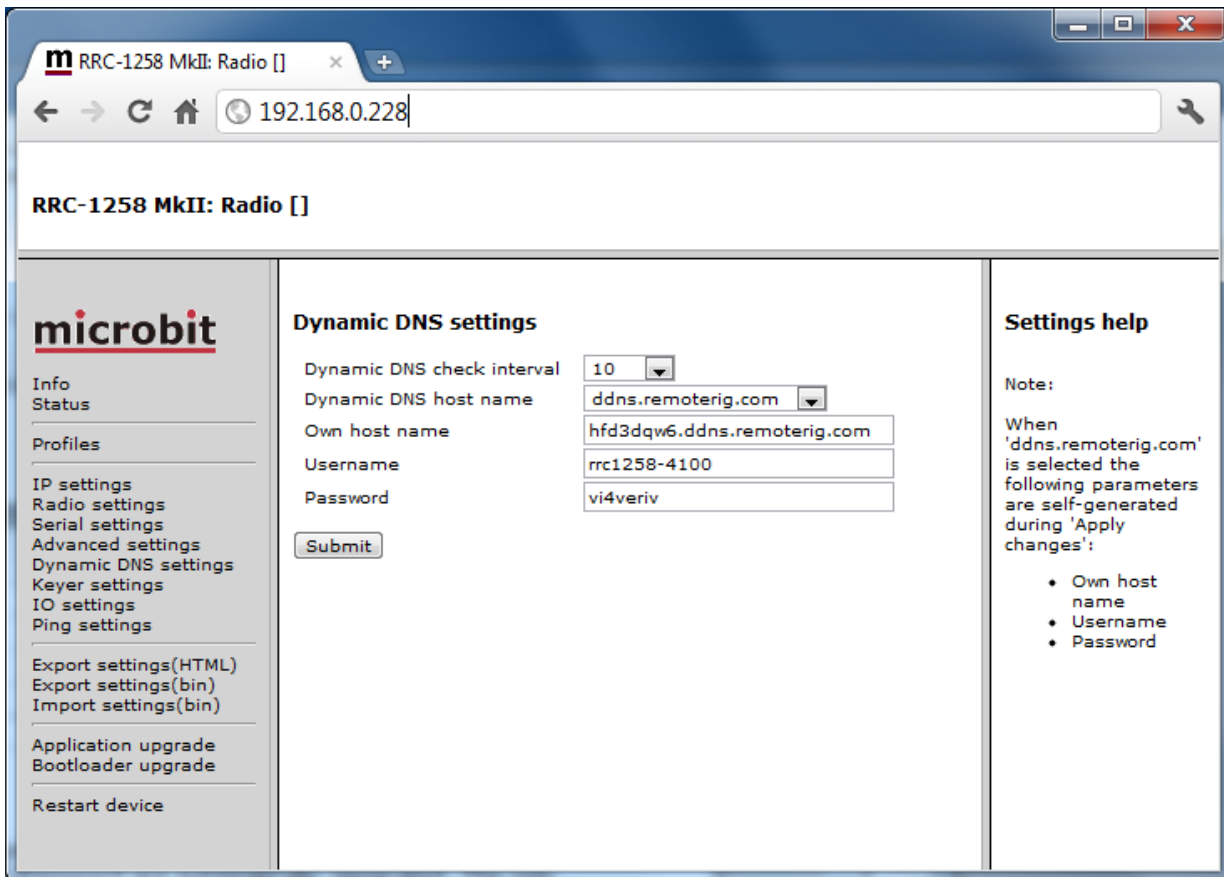

When you have done the setup and restarted the RRC, it will update the Remoterig DDNS. You can check the status of the update at <http://ddns.remoterig.com/status>

Enter the hostname from your RRC in this example = hfd3dqw6.

If your RRC has updated the DDNS you will see when and what current public IP the RRC has reported.

If it's not updated check the RRC-status page and check the DNS and DDNS status.

DynDNS dynamic dns service

The Radio-RRC also supports the commercial dynamic DNS service DynDns. Earlier this was a free service, it's still free for old users but not for new. If your router has a DynDNS client you can also use that one, and do not activate more than one DynDNS client at the same LAN segment. DynDNS do not accept multiple updates from same IP. The DynDNS client checks what IP address your router has got from the ISP and sends the information to DynDNS:s DNS server. When using DynDNS you enter "Own host name" instead of an IP address in the SIP contact setting in the Control-RRC and you don't need to bother if the IP address at the Radio-RRC changes. You need to register an account at <http://www.dyndns.com/services/dns/dyndns/> and get a domain name. There are other providers of the same service but RRC-1258MkII only supports DynDNS or Remoterig ddns.

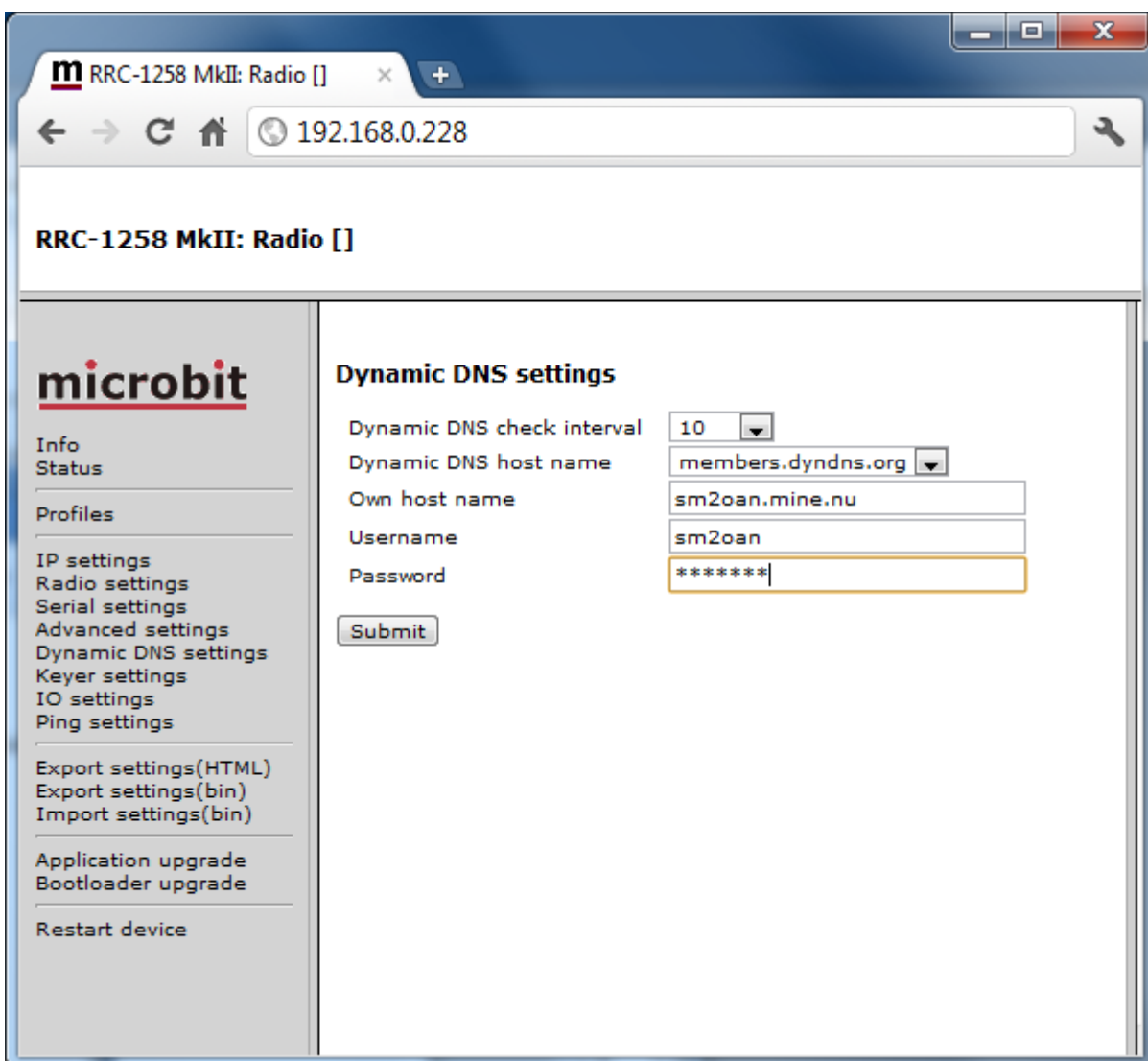

Parameter	Setting
Dynamic DNS check interval	<p>Sets how often the external IP address of your router should be checked, value in minutes:</p> <p>Off (Dynamic DNS client disabled) 10 20 30 40 50 60 180 600 1440</p>
Dynamic DNS host name	<p>Sets which DNS service you will use ddns.remoterig.com (our own free service) members.dyndns.org (commercial service)</p>
Own host name	<p>Domain name registered at DynDNS.com. Example: my-radio-site.ham-radio-op.net</p>
Username	Dynamic DNS account username.
Password	Dynamic DNS account password.

Keyer Settings (Control-RRC)

A very powerful function for remote CW operation is implemented in the RRC-1258MkII. The system is able to handle delays and jitter caused by Internet in a unique way. This function is also dependent on the I/O configuration, see IO settings. The Keyer also handles straight key CW generated from an old fashion straight keyer or a computer. The RRC also emulate a WinKeyer to be able to send CW from a log program supporting WinKeyer. The WinKeyer emulator has to be assigned to COM1, COM2 or COM3 (USB) see serial settings.

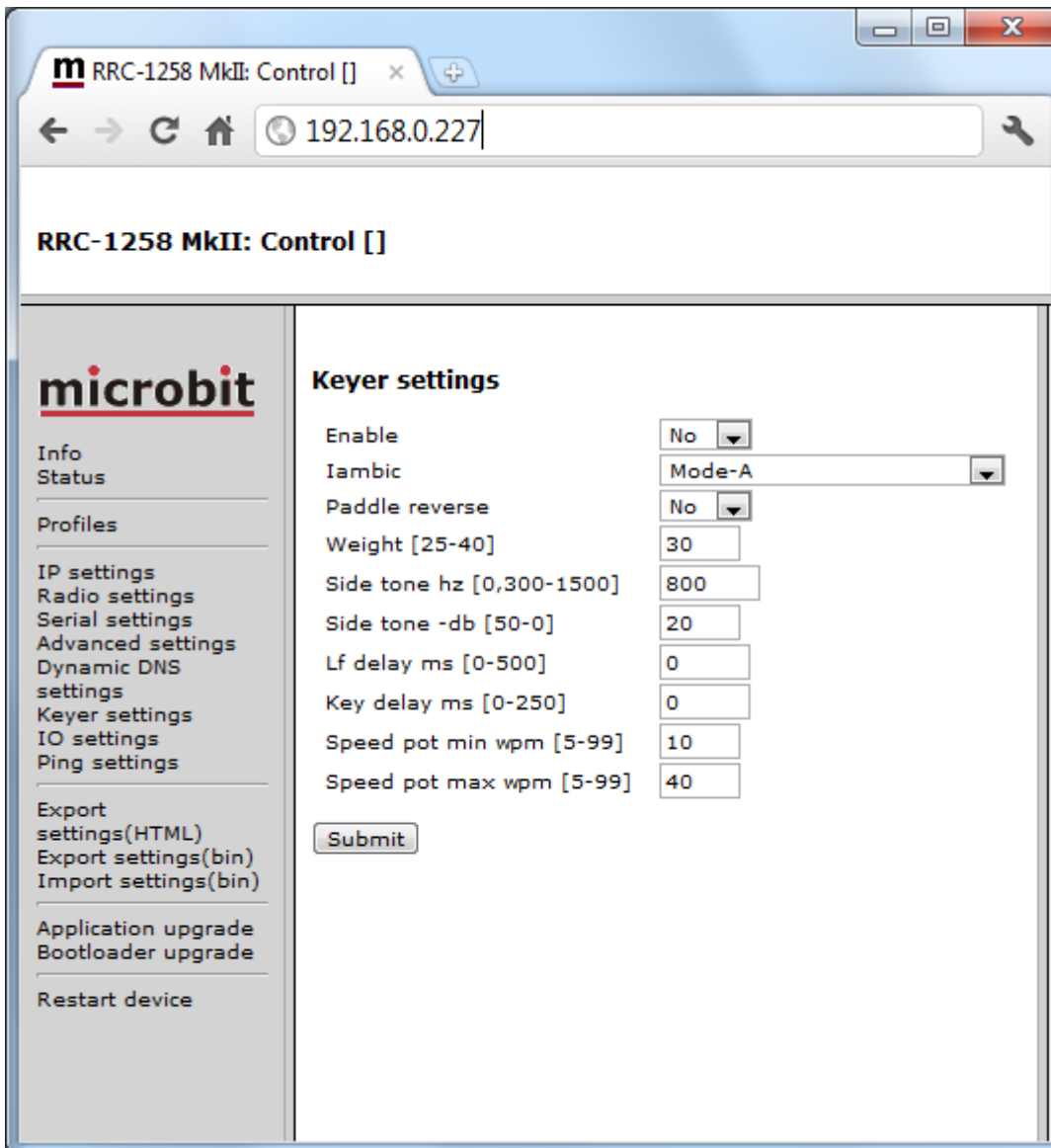

Parameter	Setting
Enable	Enable the CW-keyer function. <u>No</u> = CW-keyer is off <u>Yes</u> = CW-keyer is on (default)

Iambic	Set the CW-keyer iambic mode. <u>Old type, squeeze keyer</u> <u>Mode-A</u> <u>Mode-B (default)</u> <u>Mode-B + auto-char-space</u>
Paddle reverse	Set the reverse mode for the CW-paddle. <u>No, left paddle dot & right paddle dash (default)</u> <u>Yes, left paddle dash & right paddle dot</u>
Weight	Time ratio between dash and dot. 25-40 = 2.5-4.0/1 30 = 3.0/1 (default)
Side tone hz	Frequency for the side-tone in Hz. 0,300-1500 = side-tone frequency in Hz 800 = 800 Hz (default) 0 = No local side tone is generated, can be used to test how the CW sounds if you enable side tone in the radio and send with memory keyer or PC.
Side tone -dB	Audio level for the side-tone in dB. 50-0 = audio level in -dB 20 = -20 dBm (default)
Lf delay ms	Mute (delay) time for audio from the radio at Control-RRC after a dot/dash command. Recommendation - start with same value as the ping time. 0-500 = delay in milliseconds 0 = no delay (default)
Key delay ms	Delay time before the keying of the radio is executed at RRC- radio. 0-250 = delay in milliseconds 50 = 50 ms delay (default)
Speed pot min wpm[5-99]	Sets the lower limit of the pot range 5-99 = 5-99 wpm 10 = 10 wpm (default)
Speed pot max wpm[5-99]	Sets the upper limit of the pot range 5-99 = 5-99 wpm 10 = 40 wpm (default)

Keyer Settings (Radio-RRC)

In the Radio-RCC only one parameter is available. "PTT-activated by keyer" is a function that is useful if you want the PTT input of the radio to be activated when using the Remoterig keying function. The PPT is activated before the "Key delay" meaning that a PA for example can be activated x ms before the keying signal is activated to prevent hot switching. With the PTT tail delay you can decide how long the PTT will be kept active after the last CW character is sent.

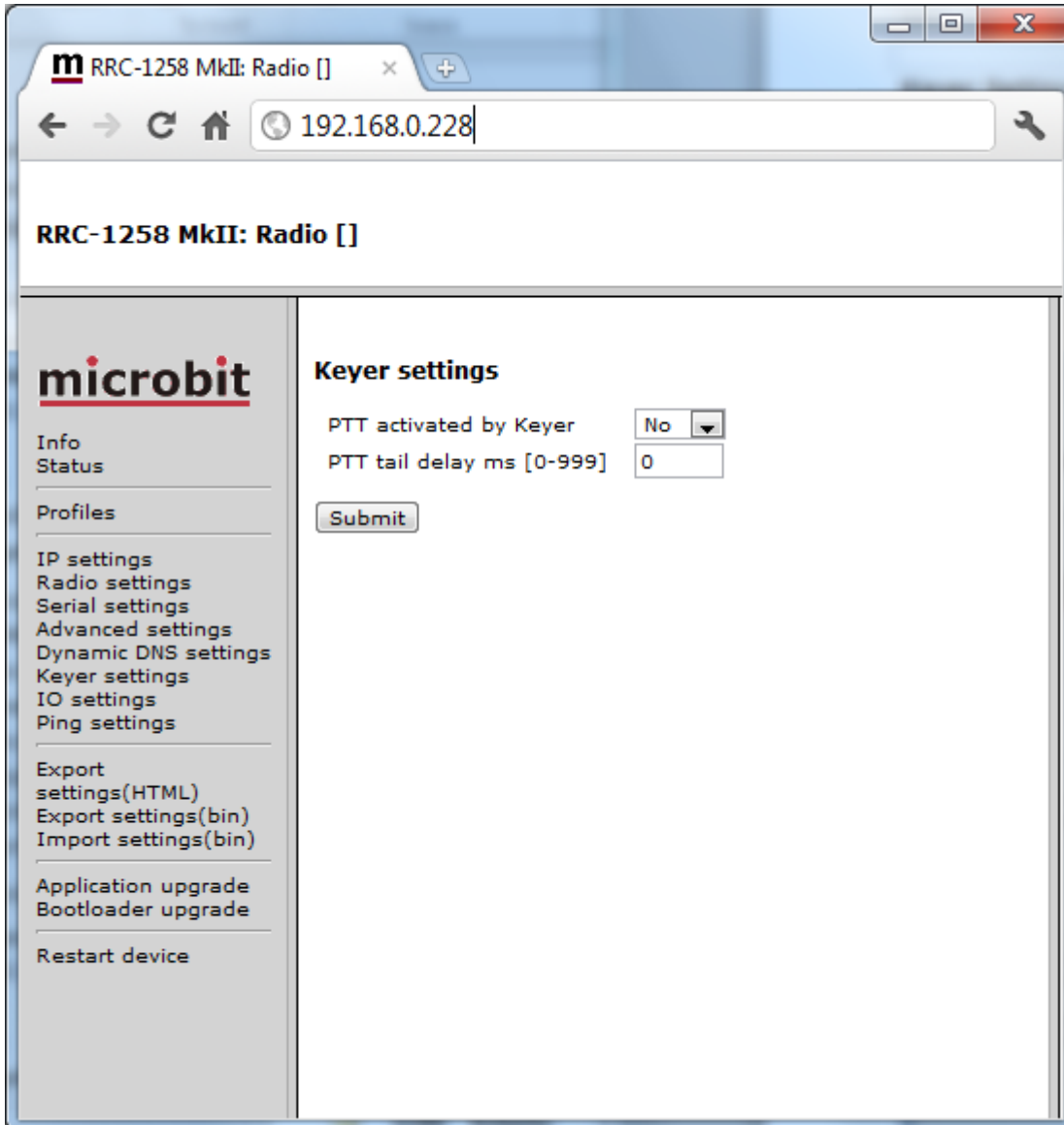

Parameter	Setting
PTT activated by keyer	Enable the PTT function. <u>No</u> = (default) <u>Yes</u> = PTT is activated by the keyer
PTT tail delay ms [999]	Enable the PTT Tail function 0 = No delay (default) 1-999 = delay in ms.

IO Settings

The inputs and outputs in both the Control-RRC and Radio-RRC are configurable to meet different needs.

Control-RRC:

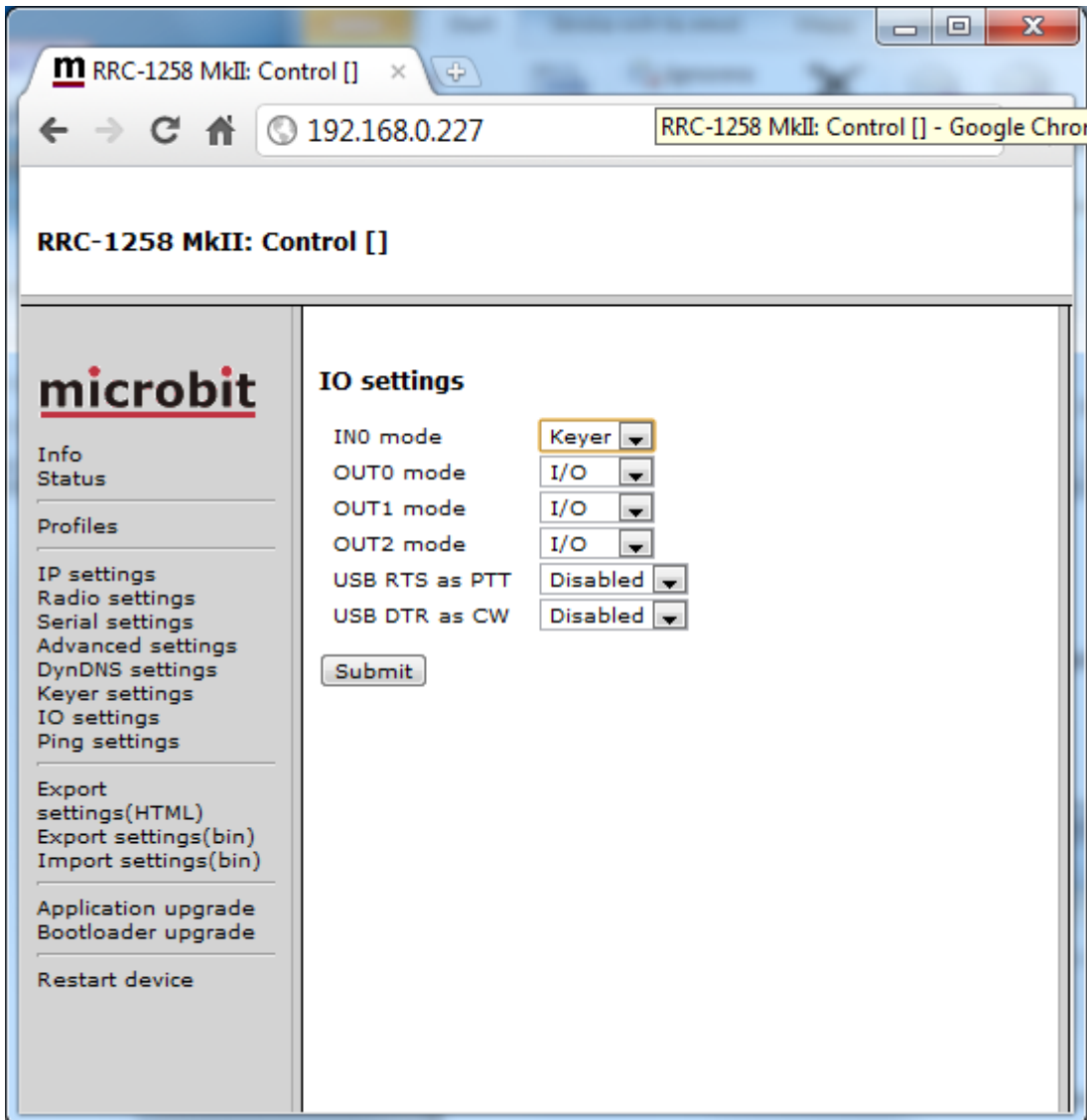

Parameter	Setting
INO mode	Select the function for Input-0 (INO) signal in the I/O connector. 0 = <u>I/O</u> , input status is transferred to Radio-RRC (default) 1 = <u>Keyer</u> , straight key or external keyer 2 = <u>PTT</u> , PTT-switch or foot-switch etc.

OUT0 mode	Output 0 can only be configured for one of two functions. I/O = Indicating that SIP connection is up. Keyer = The output follows the Keyer output.
OUT1 mode	OUT1 mode Output 1 can be configured for one of two functions. I/O = The output follows Input 1 from the Radio-RRC. Keyer = The output follows the Keyer output.
OUT2 mode	Output 2 can can be configured for one oftwo functions. I/O = The output follows Input 2 from the Radio-RRC. Keyer = The output follows the Keyer output.
USB RTS as PTT	Select which of the USB virtual COM ports RTS signal which should be used as external PTT. Useful when using Logging software, RTTY programs etc. Disabled = (default) COM0 = COM0 rts is used as PTT control COM1 = COM1 rts is used as PTT control COM2 = COM2 rts is used as PTT control
USB DTR as CW	Select which of the USB virtual COM ports DTR signal which should be used as CW key input. Useful when using Logging software, RTTY programs etc. Disabled = (default) COM0 = COM0 dtr is used as CW key input COM1 = COM1 dtr is used as CW key input COM2 = COM2 dtr is used as CW key input

Radio-RRC:

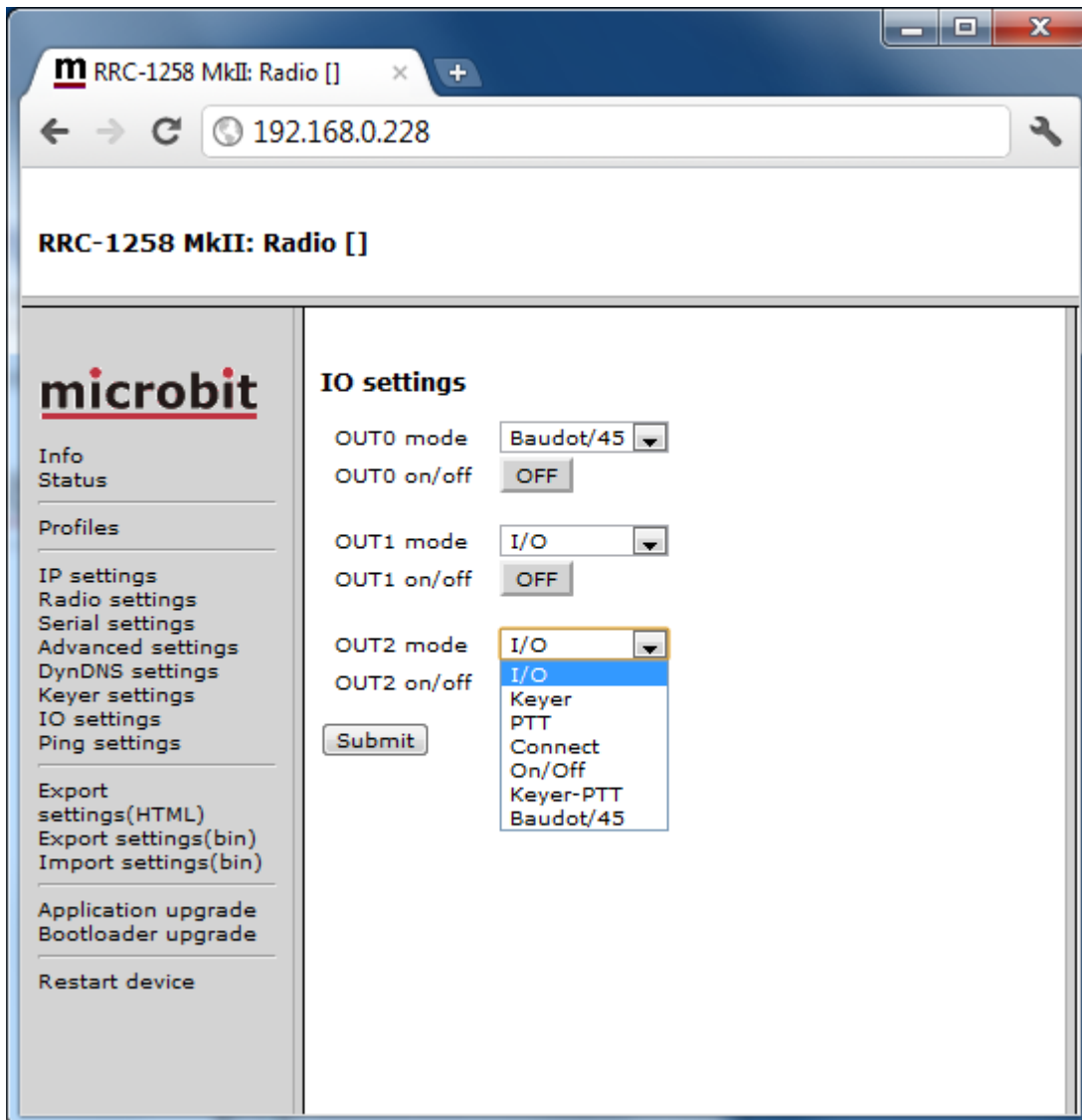

Parameter	Setting
OUT0 mode	<p>Select the function for output-0 (OUT0) signal the I/O connector.</p> <p>0 = <u>I/O</u>, active when IN0 on Control-RRC is active (Control-RRC IN0-mode setting must be in state I/O). (default)</p> <p>1 = <u>Keyer</u>, output to the radio straight key input</p> <p>2 = <u>PTT</u>, used as external PTT</p> <p>3 = <u>Connect</u>, active when the SIP-connection is active</p> <p>4 = <u>On/Off</u>, controlled by the ON/OFF button on this side (*)</p> <p>5 = <u>Keyer PTT</u>, active when CW is send via the keyer (can be used to key a PA). If you set "key delay" in the Control-RRC this output will be activate "key delay" ms before the actual CW-keying is started.</p> <p>6 = Baudot/45 used as output for RTTY 45.45 baud. RTTY input via USB virtual com port at Control-RRC. Connect PC software to the virtual com named FSK COM.</p> <p>7 = Baudot/45 (inv) same as above but the RTTY key signal is inverted.</p>
OUT1 mode	<p>Select the function for output-1 (OUT1) signal the I/O connector (or tip in the PAD-jack).</p> <p>0 = <u>I/O</u>, active when IN0 on Control-RRC is active. (Control-RRC CW-Keyer function must be disabled). (default)</p> <p>1 = <u>Keyer</u>, output to the radio straight key input</p> <p>2 = <u>PTT</u>, used as external PTT</p> <p>3 = <u>Connect</u>, active when the SIP-connection is active</p> <p>4 = <u>On/Off</u>, controlled by the ON/OFF button on this side (*)</p> <p>5 = <u>Keyer PTT</u>, active when CW is send via the keyer (can be used to key a PA). If you set "key delay" in the Control-RRC this output will be activate "key delay" ms before the actual CW-keying is started.</p> <p>6 = Baudot/45 used as output for RTTY 45.45 baud. RTTY input via USB virtual com port at Control-RRC. Connect PC software to the virtual com port named FSK COM.</p> <p>7 = Baudot/45 (inv) same as above but the RTTY key signal is inverted.</p>
OUT2 mode	<p>Select the function for output-2 (OUT2) signal the I/O connector (or ring in the PAD-jack).</p> <p>0 = <u>I/O</u>, active when IN0 on Control-RRC is active. (Control-RRC CW-Keyer function must be disabled).</p> <p>1 = <u>Keyer</u>, output to the radio straight key input. (default)</p> <p>2 = <u>PTT</u>, used as external PTT</p> <p>3 = <u>Connect</u>, active when the SIP-connection is active</p> <p>4 = <u>On/Off</u>, controlled by the ON/OFF button on this side (*)</p> <p>5 = <u>Keyer PTT</u>, active when CW is send via the keyer (can be used to key a PA). If you set "key delay" in the Control-RRC this output will be activate "key delay" ms before the actual CW-keying is started.</p> <p>6 = Baudot/45 used as output for RTTY 45.45 baud. RTTY input via USB virtual com port at Control-RRC. Connect PC software to the virtual com port named FSK COM.</p> <p>7 = Baudot/45 (inv) same as above but the RTTY key signal is inverted.</p>

(*) When the ON/OFF buttons are pushed the output change will be immediate, but will resume to last saved position after power on. To make the changes permanent use the "apply changes" button.

Ping settings (only Radio-RRC)

The Radio-RRC has a Ping Watchdog function which can be used as an extra security. This function is quite common in network equipments. It can be set to ping an IP address and when it does not get any answer, it will make a hard reboot of the RRC. The status of the ping watchdog can be checked at the status page. This function is only available on the Radio-RRC.

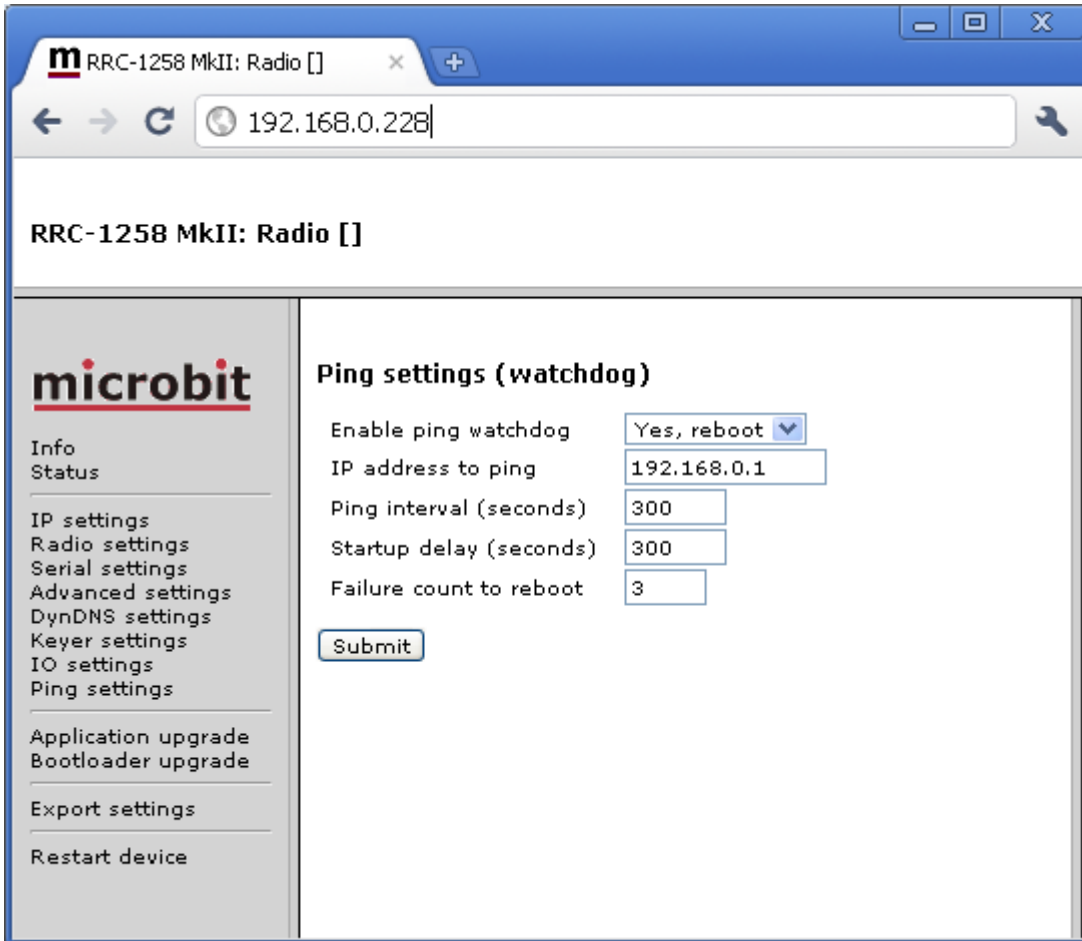

Enable ping watchdog	Enables the function. No = Function is disabled Yes, test = Function enabled but it will not actually reboot, can be used for test Yes, reboot = Function is enabled.
IP address to ping	IP address to ping is entered here, In normal cases use the Gateway IP.
Ping Interval (seconds)	Interval between the ping is sent. (1-65535, default 300 s)
Startup delay (seconds)	Delay before the first ping is sent. (300-65535), default 300 s. If Test mode is activated it can be set to 10-65535
Failure count to reboot	Sets how many times the ping is allowed to fail before reboot is done. (1-255, default 3)

Wi-Fi settings

You can enter SSID and Password direct or check them on the WiFi page. See more in the WiFi Chapter.

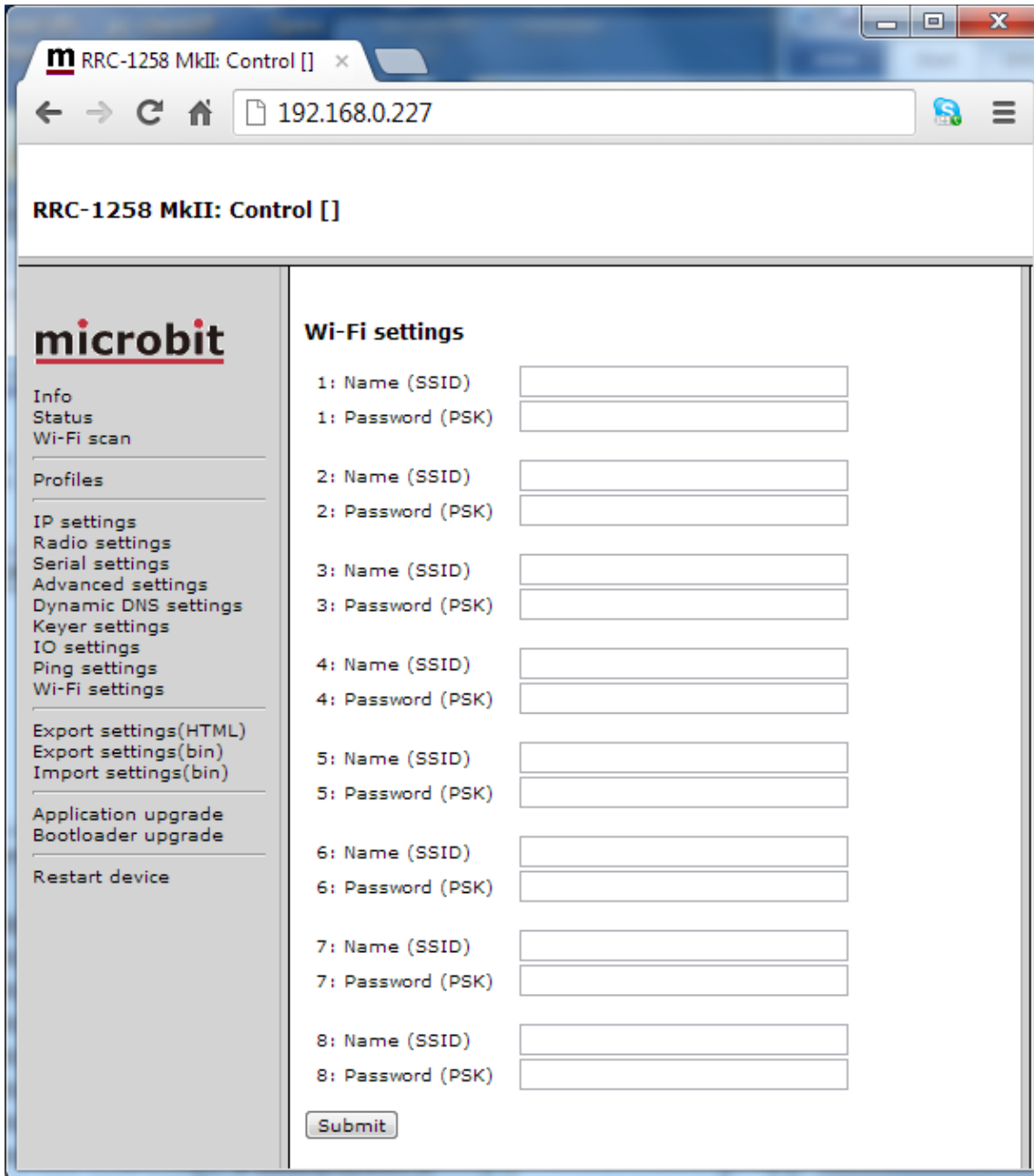

Export settings (HTML)

This function creates a text file with the actual settings and status of the unit. This file can be sent via email for support purposes for example.

Export settings (bin)

This function is used to backup your settings to a file in your PC. When clicking on the link a dialog box will show up where you can decide where to store and the name of your backup file.

Note! The exported file will only include settings for the active profile.

Import settings (bin)

This function is used import your backup file from your PC. Click on select file and browse to your file and then click import.

Note that the imported settings will be stored in the currently selected profile.

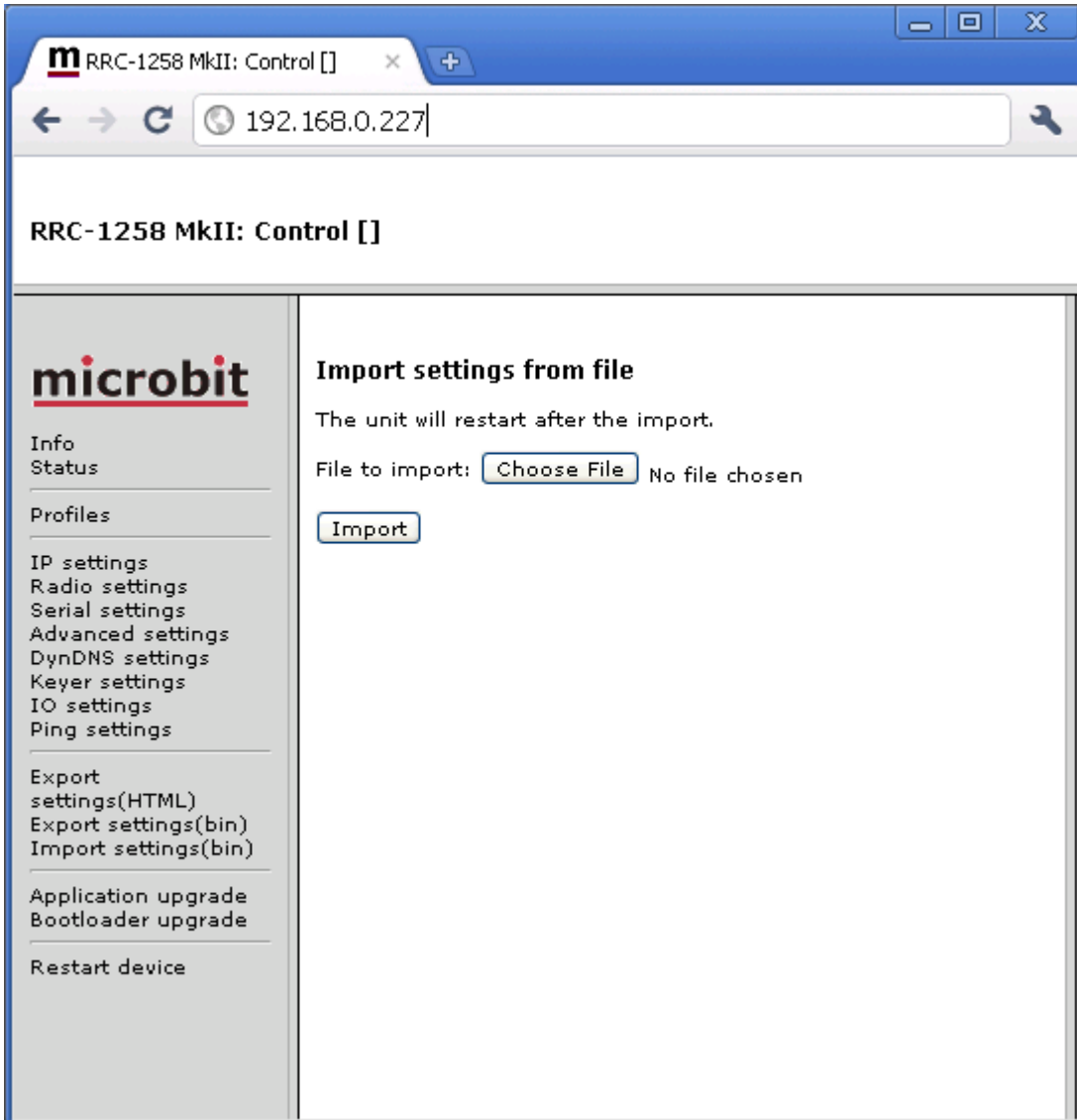

Application firmware upgrade

The application firmware can be updated over the Internet via the web interface when bugs are fixed and/or new functionality is implemented. You don't have to be where the RRC-1258MkII is to do the updates. Download the new firmware from www.remoterig.com and save the file on your computer (it has a name like RRC1258-CRC_v1.38_2009-09-04.bin).

Connect to the RRC you want to update and select 'Application-upgrade'. Then click on the 'Browse' button and select the file with the new firmware. After that you click on the 'Upgrade' button and the new firmware will be transferred and saved into the RRC. When the firmware is updated the RRC will restart. Note -- Do not interrupt the upgrade process in any way.

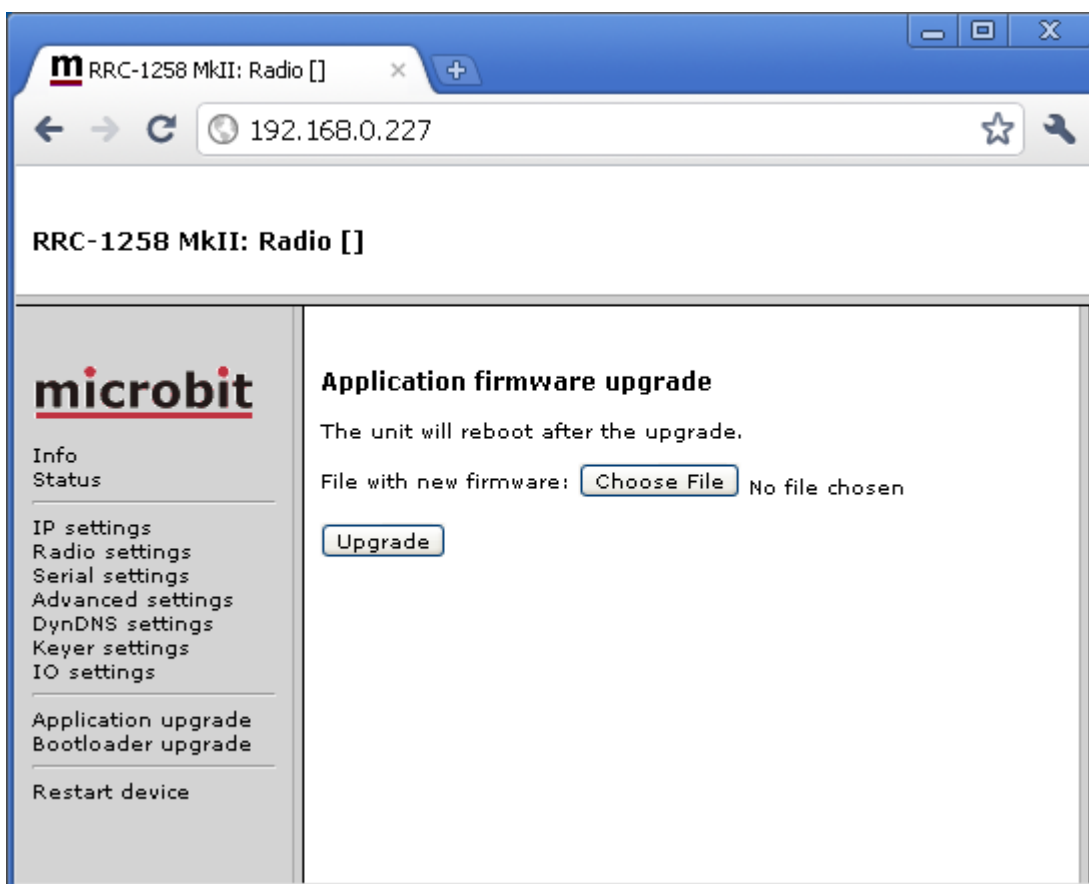

Wait a minute or two then connect to the RRC again and select 'Info' and verify that the Software version is updated. If it looks like its not updated empty the web browser cache, to prevent it from showing an old cached page. The update NEVER fails but the browser is a common problem.

Bootloader firmware upgrade

This follows the same steps as the application firmware upgrade procedure above.

Restart device

Restart device can be used if you want to reset and restart the RRC without saving any changes (before apply changes) or just for ordinary reset.

Configuration with terminal-interface

All parameters can also be programmed via the serial interface COM1 (RS-232) or Telnet port. COM1 has the following settings: 38400 baud, 8 bits, No parity, and 1 stop bit. Select the sys [s] and setup-edit [1] menus to configure the RRC. This method of configuration is not user friendly and should be avoided.

```
=====
a: audio
c: codec
d: debug
e: extio
f: flash
i: sip
l: led
q: audio quality
p: power
r: radio
s: sys
u: usb
=====
s

sys
=====
1: setup edit
2: setup view
3: setup clear
4: sntp
5: rtc
6: wdt reset
7: dns query
8: show network info
9: STUN test
0: memory
a: UDP send
b: UDP receive
c: Setup default 1(Control)
d: Setup default 2(Radio)
r: COM1-rts/cts on/off
q: exit
```

WiFi



General

The RRC-1258 can be equipped with a WiFi Interface. A WiFi interface is convenient when you want to connect the RRC:s to a WiFi network. You do not need any extra cables or boxes. For the Control-RRC the main reason to use WiFi might be the portability, and for the Radio-RRC to physically separate the RRC from the telephone/DSL line which is the most common route for lightning storms to hit the RRC and the Radio.

The WiFi Interface is mounted on the pin header P3 in the RRC-box. Units produced from the summer 2012 has P3 in place from production. Units produced earlier do not have P3 in place you have to solder to put it in place, Instruction for how this is done can be found on the Remoterig website under Support/Mods (hardware).

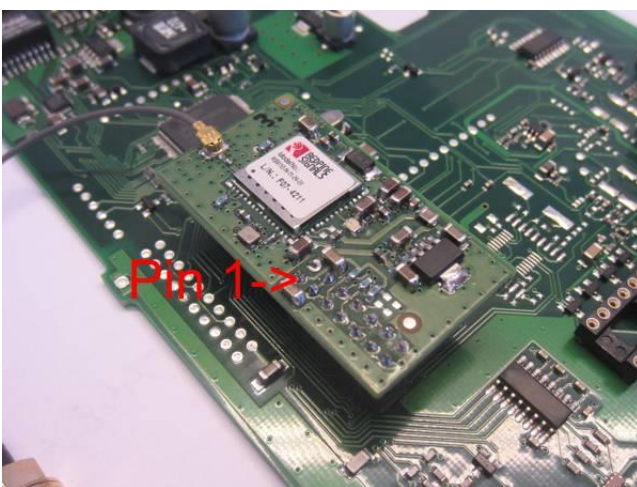

The 2.4 GHz Wifi Interface is compliant to 802.11b/g and single stream 802.11n and supports WPA2- (AES), WEP (64 and 128 bit) modes of security in infrastructure mode and also TKIP in SPI mode.

There is no limitations compared to Ethernet, all settings that are used when they are connected to Ethernet can be used.

The RRC automatically switch between WiFi or Ethernet. IF Ethernet is connected, Ethernet will be used.

Connecting to a Wifi network

The easiest way to setup the WiFi connection is to do it via the Microbit Setup manager. If you know the parameters it can be done from the web interface also, but you cannot scan WiFi Networks that way so we focus on using the Setup manager.

Do not forget to connect 12V power to the RRC, the setup works when the unit is powered from USB but you can not scan for WiFi networks until you connect 12V.

The RRC can store settings for up to 8 different WiFi networks. The RRC will automatically connect to the strongest network from the list. You can not force the RRC to connect to a specific network, if you must do that, you have to remove the unwanted network from the list.

- Disconnect the Ethernet cable if it's connected, Connect 12V to the RRC, and connect the USB cable from your PC to the RRC. Start the Microbit setup manager
- Select the WiFi tab

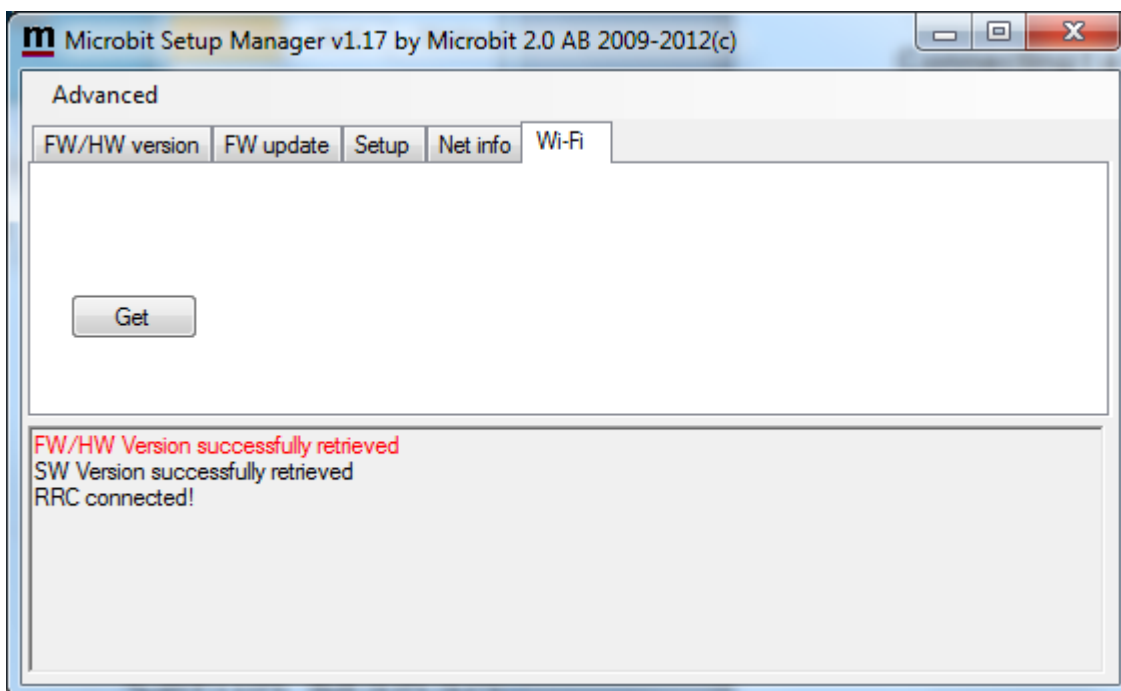

Click on the Get button.

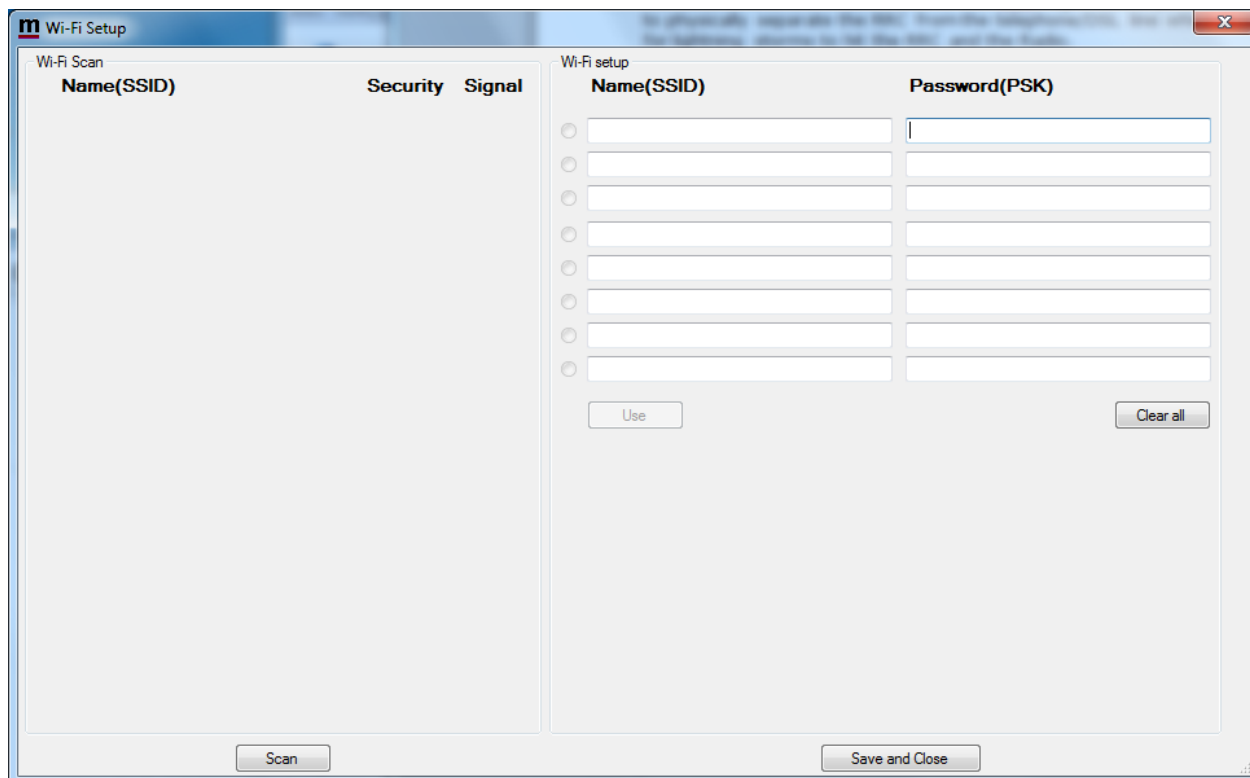

- You will get a empty page when the unit is not programmed, when you later open this page you will see the stored settings for your WiFi networks. Click Scan.

- After a 1 second you will see the WiFi networks which are available at your current location. The networks are sorted in order decided by Signal strength, the strongest on top. Up to 32 WiFi networks can be shown.

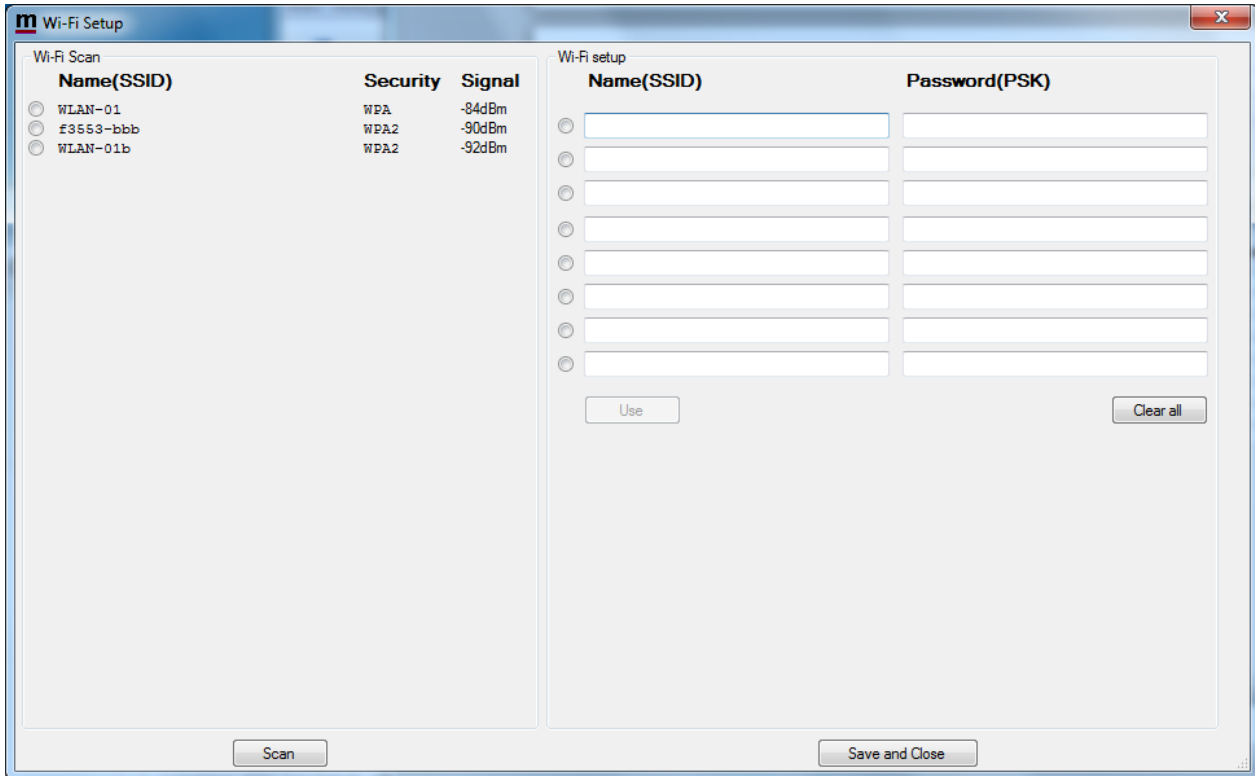

- Select the network you want to use by clicking on the button beside the SSID.
- Click on the button on the row where you want to store the Network.
- Click on the "use" button.
- Enter the password (Private shared key) if it's needed.
- Click "Save and close" button.

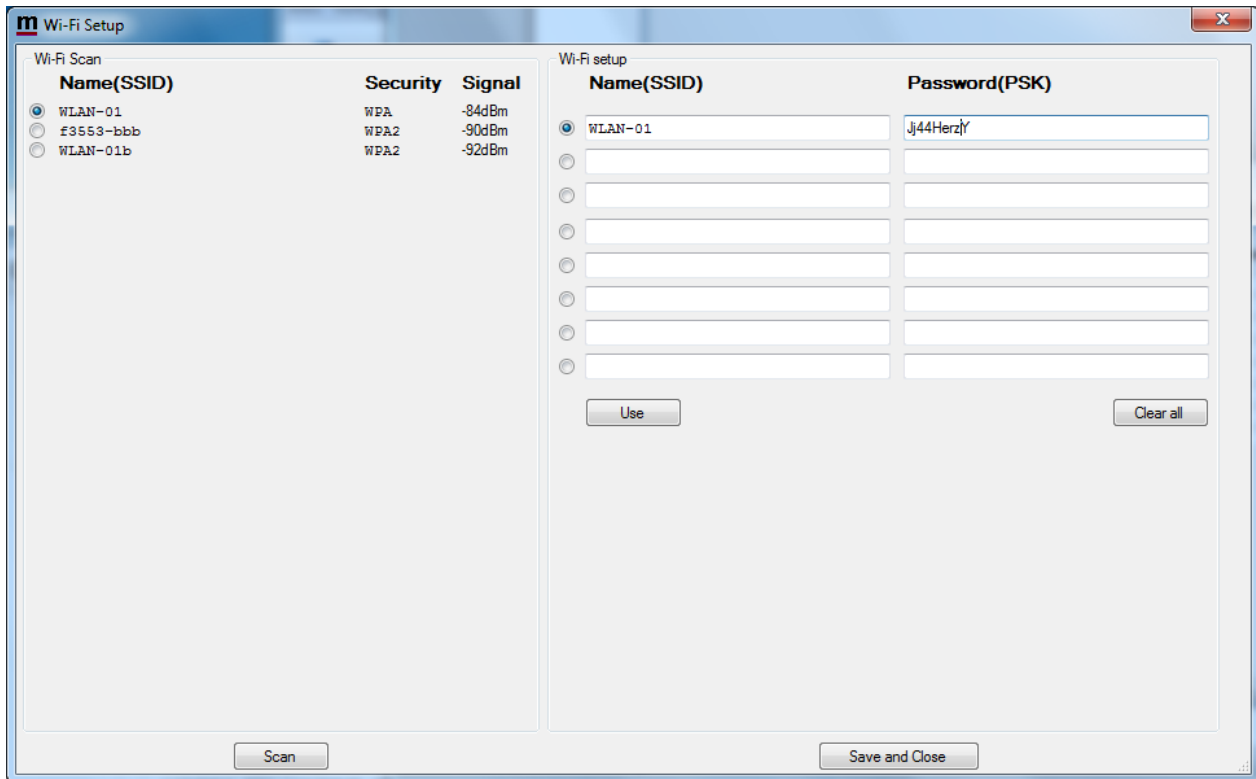

- Give The RRC a few seconds to reboot and connect to the WiFi Network.
- Click on the Net info tab.
- Click on the "Get" button. You will now see that the Box has got an IP-address from the DHCP- server. If it still shows 000.000.000.000 etc. wait a moment and click on the "Get" button again

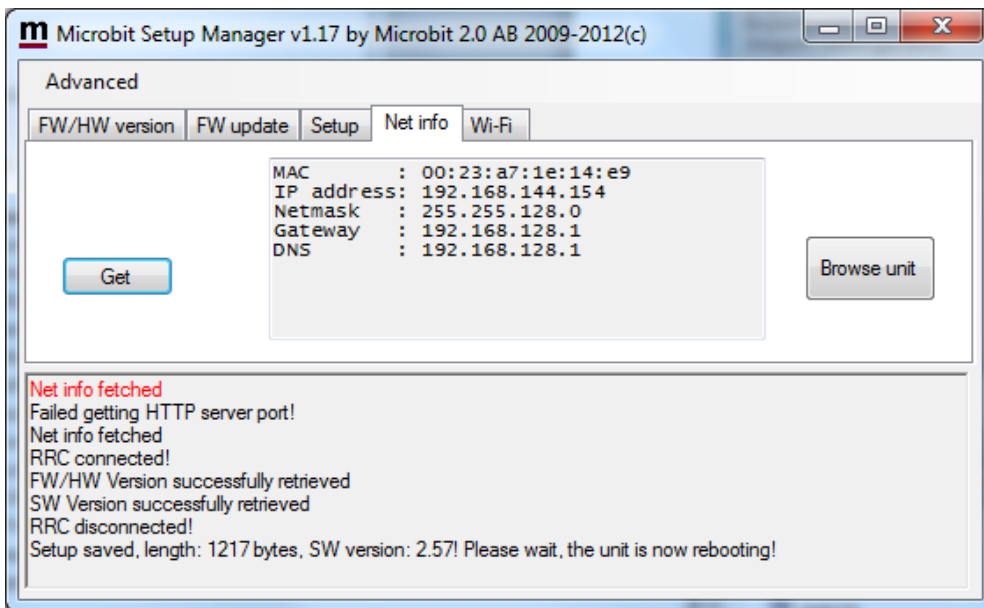

- Click on the "Browse unit" button. You will now see the RRC internal web pages(*1).
- Click on "Info" and you will see the WiFi network status

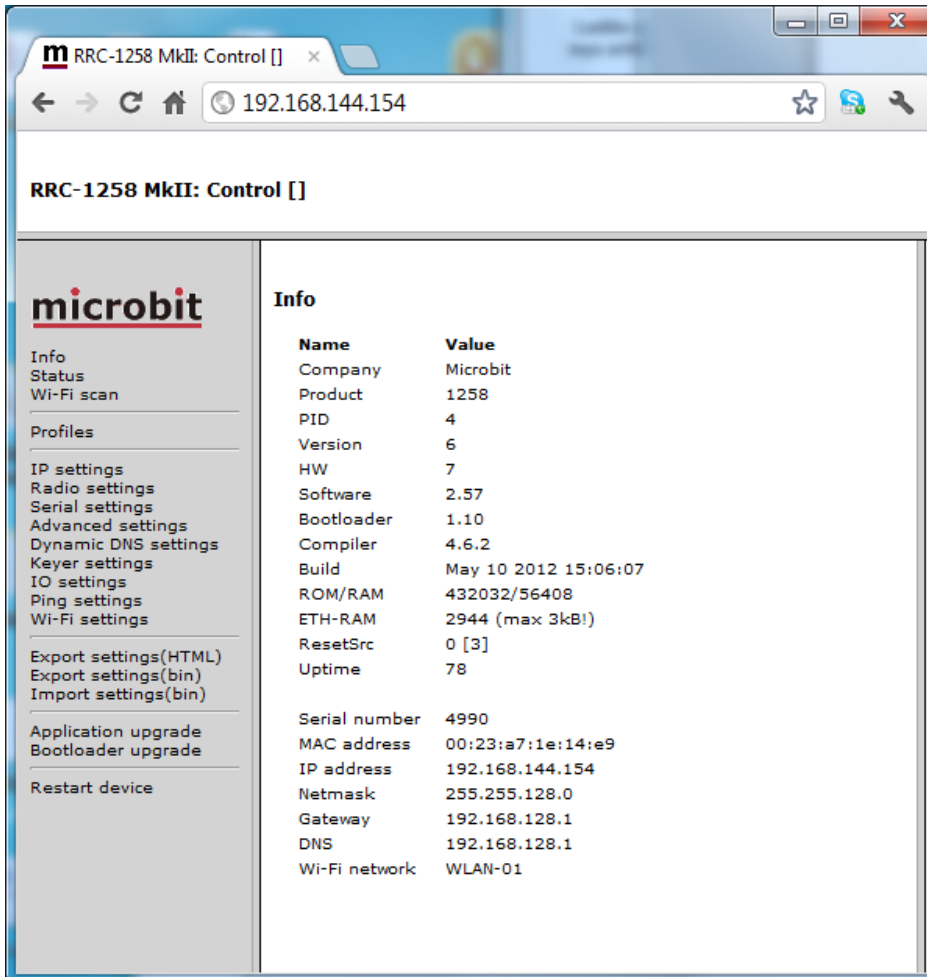

*1 - Your PC has to be connected to the same network as the RRC if it should be possible to connect to it. If the PC is connected to the same WiFi Network, "wireless isolation" must be switched off in the Router/access point.

CW-Keyer

General

The RRC-1258 has a CW-keyer function that makes CW operation possible over Internet even if there are long latencies and lots of jitter. Note that the CW-keyer is by default disabled.

The CW-keyer side-tone is generated locally at the control RRC. When the dot or dash is executed the audio from the radio can be muted at the Control-RRC to disable the radio side-tone or annoying clicks and sounds. The time the mute function is active is defined by the lf-delay setting. The value of lf-delay depends on the latency of Internet. A good start value is the same value as the ping time between control and radio QTH.

Another unique feature is a kind of adjustable jitter buffer at the radio end. If the Internet connection has varying latencies, you can set a key-delay before the keying of the radio is executed. This delay makes it possible to reconstruct the transmission on-the-fly and the system will be much more tolerant against varying latencies (jitter). Longer key-delays give higher tolerance against jitter but also add delay until the keying is executed at the radio. Even if you have a good connection you could try with a low value. Remember that when you increase this value you must also increase the lf-delay value.

Settings

Keyer settings:	Control	Radio
Enable	Yes	
Iambic	Mode-A	
Paddle reverse	No	
Weight [25-40]	30	
Side tone hz [500-1500]	800	
Side tone -dB [50-0]	20	
Lf delay [0-500]	0	
Key delay [0-250]	0	

IO settings:	Control	Radio
IN0 mode	I/O	
USB DTR as CW	No	
OUT0 mode		I/O
OUT1 mode		I/O
OUT2 mode		Keyer

Connections

PAD – Control-RRC:

At the Control-RRC the PAD-jack is used to connect a CW-paddle. The input is for a standard 3.5 mm stereo plug. The left paddle is connected to the tip and the right paddle to the ring. Common is connected to the inner ring and house. Note - these signals are also available in the I/O-connector.

Signal	PAD jack	IO setting
left-paddle	tip	-
right-paddle	ring	-
gnd	inner ring	-

PAD – Radio-RRC:

At the Radio-RRC the PAD-jack is used to connect the output signal from the CW-keyer to the radio straight-KEY input. The output is for a standard 3.5 mm stereo plug. A standard cable with 3.5 mm connector in both ends can often be used. Note - these signals are also available in the I/O-connector.

Signal	PAD jack	IO setting
keyer-output	tip	OUT2 mode = Keyer
keyer-output	ring	OUT1 mode = Keyer
gnd	inner ring	-

USB – Control-RRC:

A PC with straight-key functionality can be used to perform the keying, alone or in combination with a CW-paddle. To activate keying the PC could use the DTR signal in the virtual USB COM-port delivered by the RRC USB device. The PC control works in parallel with the CW-paddle so it is possible to shift between PC-keying and the CW-paddle without changing the configuration.

I/O-connector – Control-RRC:

A PC with straight-key functionality or other external keyer can be used to perform keying, alone or in combination with a CW-paddle. To activate keying connect pin-4 (IN0) to GND. The external keyer works in parallel with the CW-paddle so it is possible to shift between external keying and the CW-paddle without changing the configuration.

Note - The straight-key input (IN0) is a generic input and cannot be connected direct to a PC, you need an interface, see appendix.

Signal	I/O connector	IO setting
right-paddle	1 (IN1)	-
left-paddle	2 (IN2)	-
straight-key/PC	4 (IN0)	IN0 mode = Keyer
gnd	8	-

I/O-connector – Radio-RRC:

The output signal from the CW-keyer to the radio straight-KEY input can also be found in the I/O connector.

Signal	I/O connector	IO setting
keyer-output	5 (OUT0)	OUT0 mode = Keyer
keyer-output	6 (OUT1)	OUT1 mode = Keyer
keyer-output	3 (OUT2)	OUT2 mode = Keyer
gnd	8	-

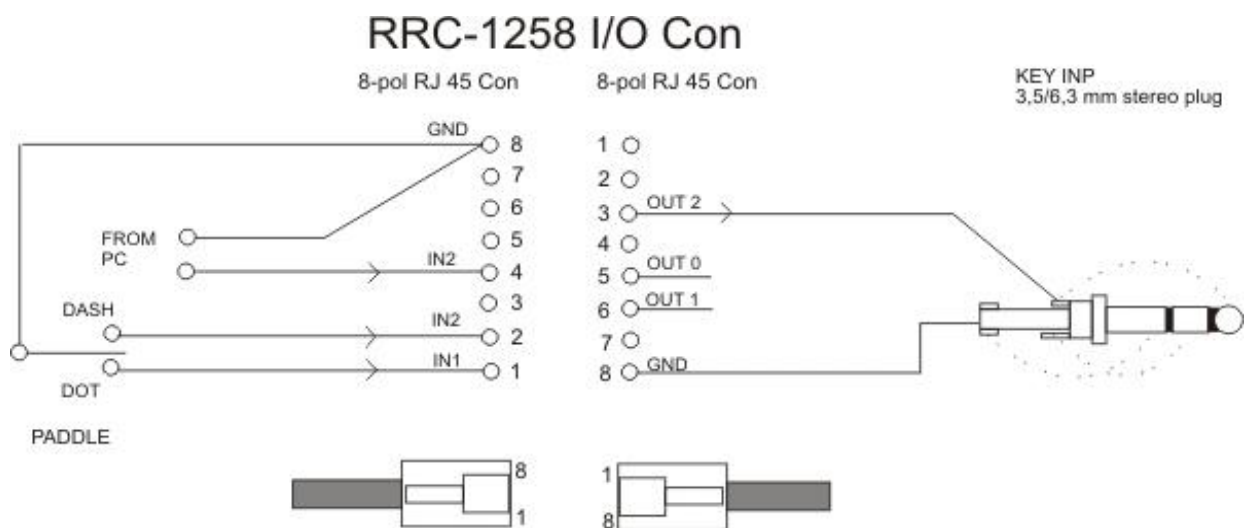

RTTY Keying

General

Most HF-radios have a special FSK/RTTY keying input which is better to use than AFSK (audio frequency shift keying) since you don't need to set mic gain and other settings. The RRC-1258 has a separate serial channel for transfer of 45.45 baud RTTY keying data. The RTTY serial channel is only available via the USB interface.

When installing the Microbit Setup manager a USB-driver called COMExtra is installed

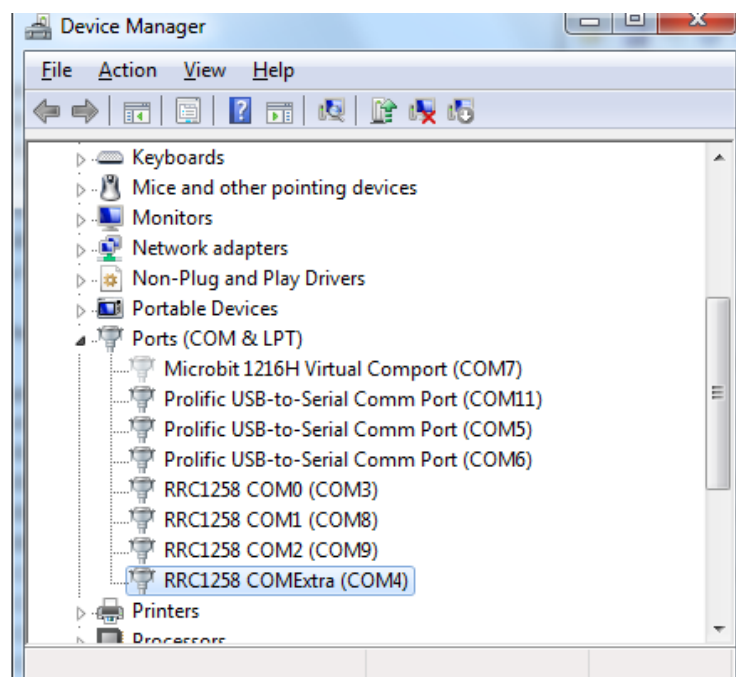

In your RTTY PC-Software you should select the serialport number assigned to the driver by Windows, in the example above it's COM4.

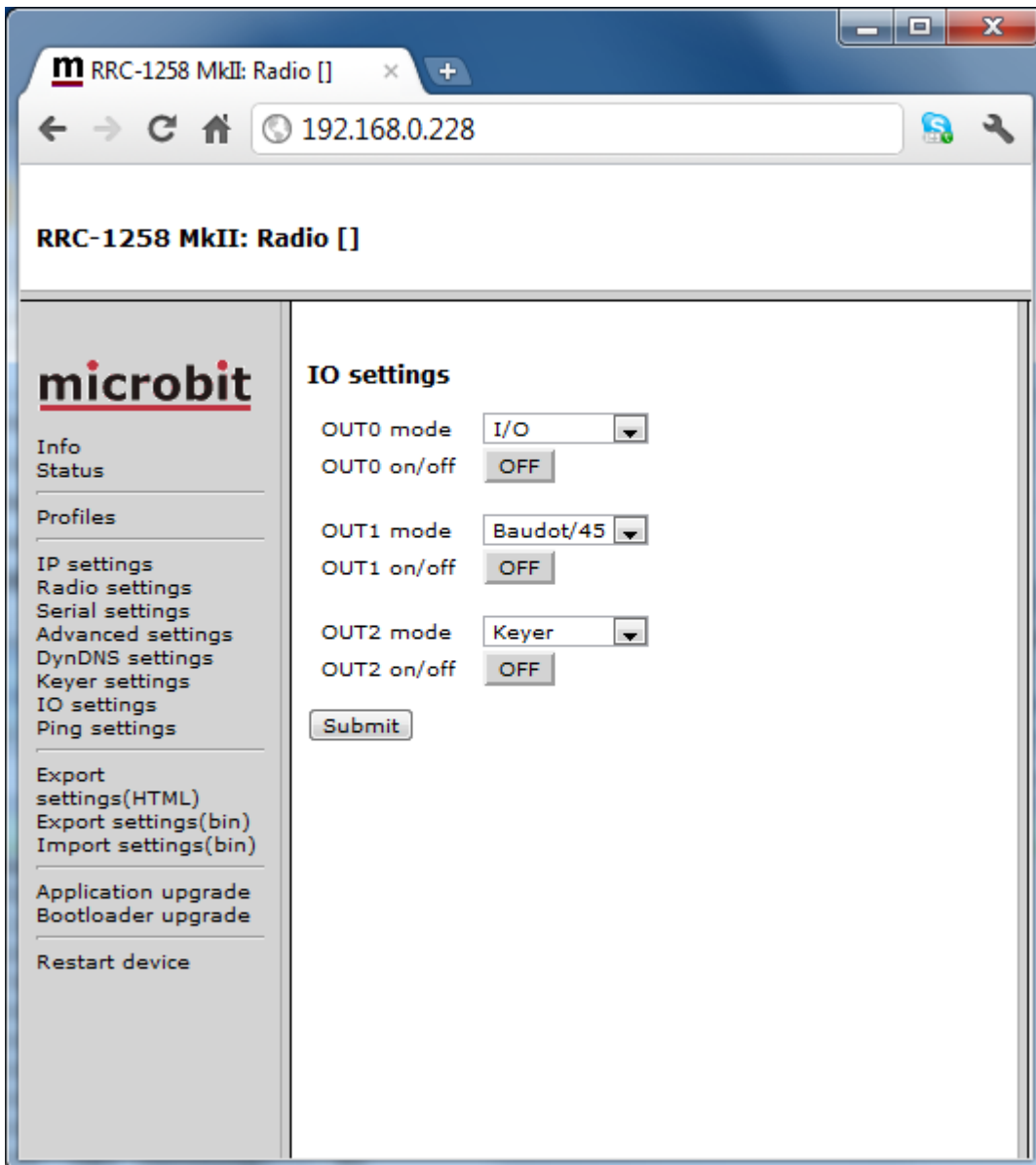

At the Radio-RRC IO-settings page you need to select which output you want to use for the RTTY keying signal. RTS from the RRC-1258 COMExtra USB port is used to key PTT.

RTTY with MMTTY

The Remoterig specific settings to use MMTTY for RTTY is shown below.

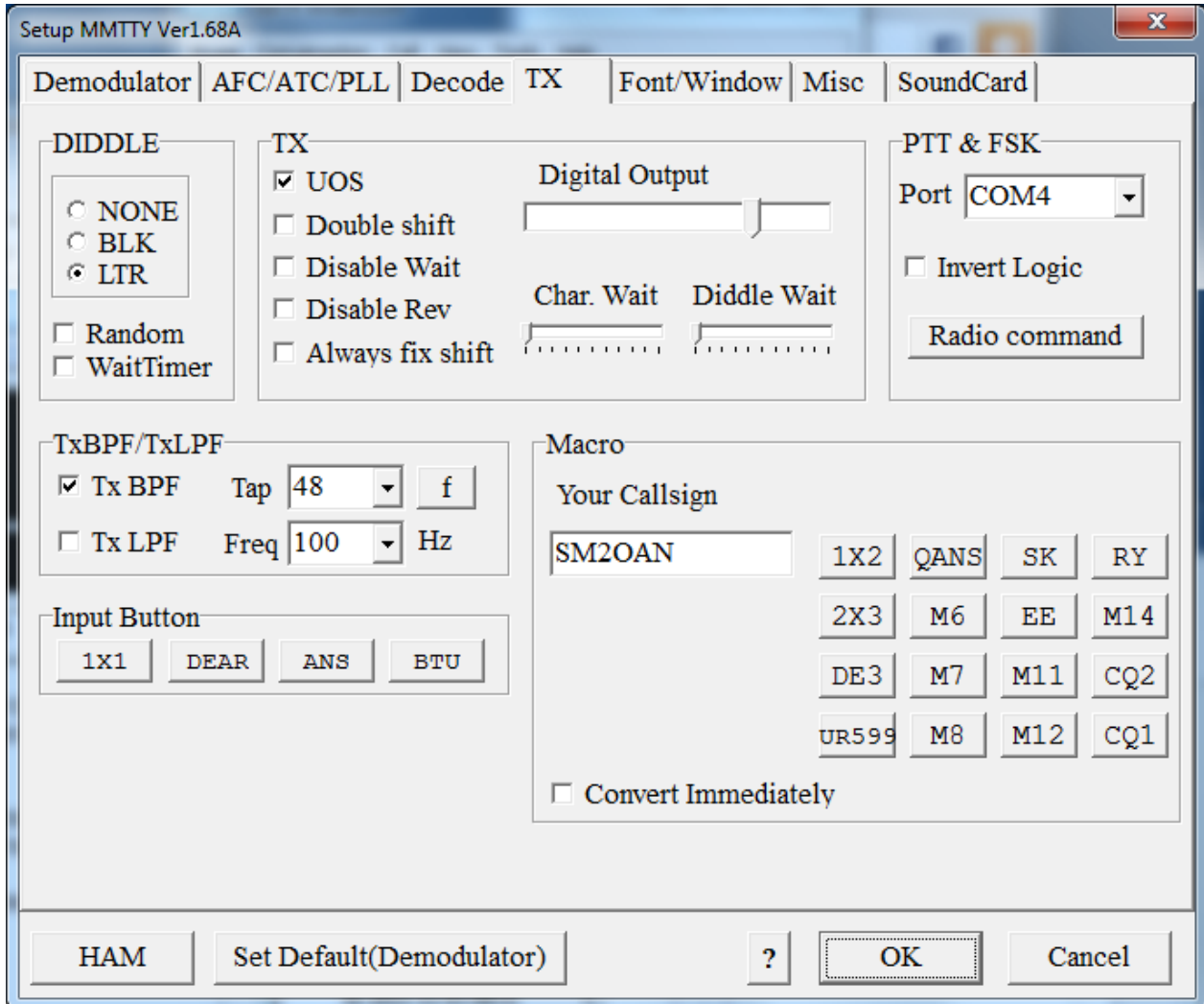

At the TX tab select the PTT & FSK comport to the same comport as Device Manager showed to be assigned to RRC-1258 COMExtra port, in this example it's COM4.

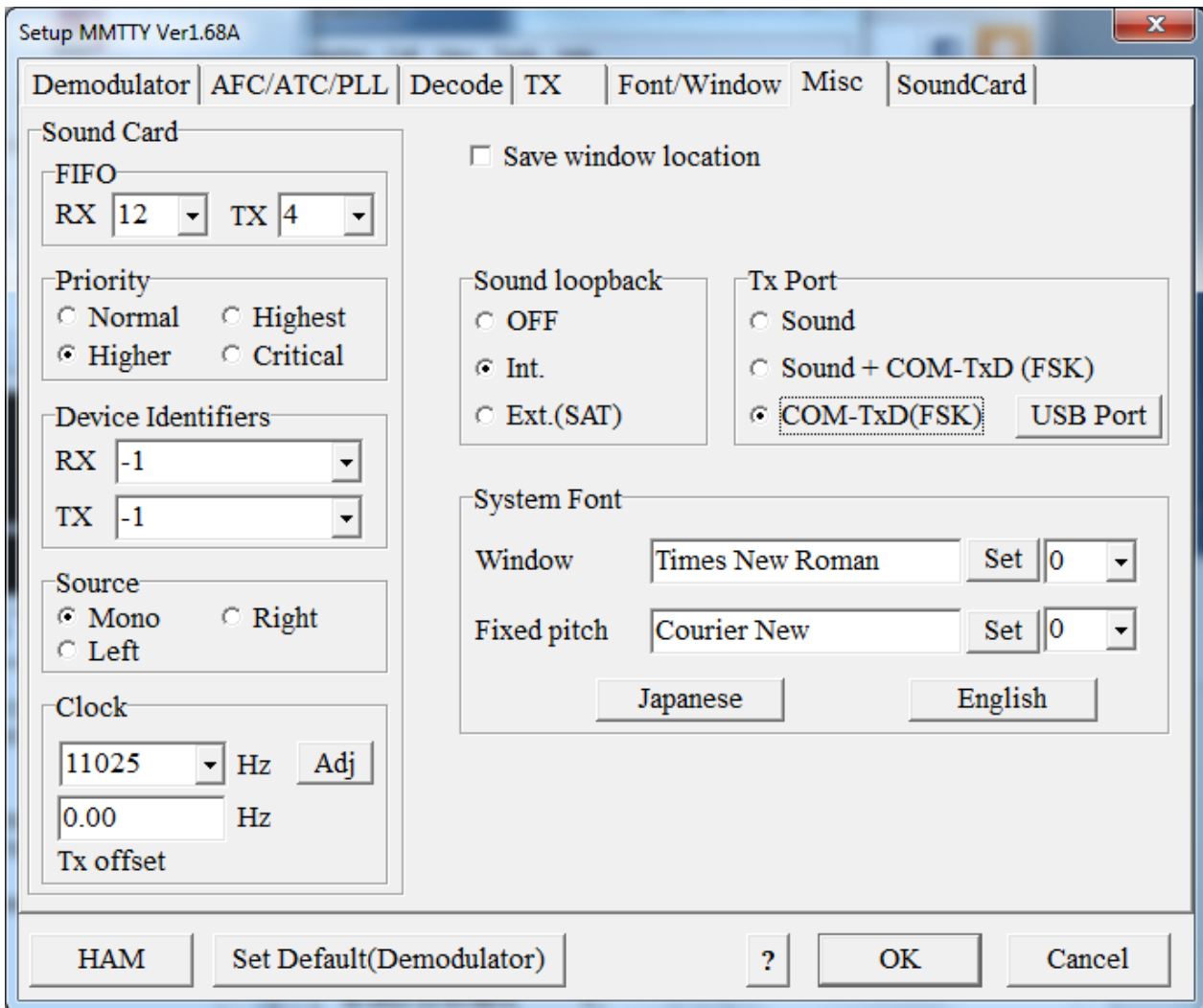

At the Misc tab e select COM-TxD(FSK) and click on the “USB Port” button.

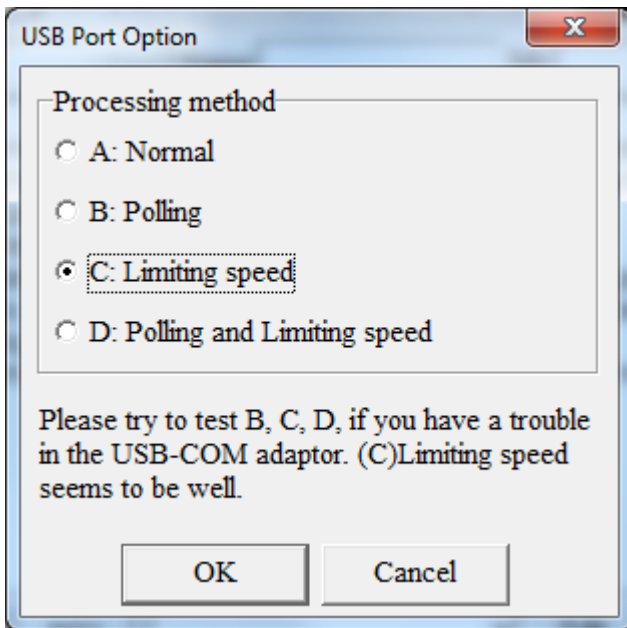

In the "USB port option" dialog select "C-limiting speed". If not limiting speed is selected the PTT will be released before the whole RTTY string is sent, because the USB communication is so much faster than a ordinary RS-232 serial port.

Settings

IO settings:	Control	Radio
OUT0 mode		-
OUT1 mode		Baudot/45
OUT2 mode		Keyer

Connections

PAD – Control-RRC:

Only the USB interface can be used for RTTY as described above.

PAD – Radio-RRC:

At the Radio-RRC the PAD-jack can be used to connect the RTTY signal from the FSK serial port. The PAD will then be shared with CW key output. The pad jack is for a standard 3.5 mm stereo plug. Note - these signals are also available in the I/O-connector.

Signal	PAD jack	IO setting
keyer-output	tip	-
keyer-output	ring	OUT1 mode = Baudot/45
gnd	inner ring	-

USB – Control-RRC:

A PC with a suitable software like MMTTY can be used to perform the RTTY keying. Together with the RTTY keying signal PTT need to be activated this is done by activating the RTS signal in the virtual comport (COMExtra). MMTTY does this by default other software may need manual configuration.

I/O-connector – Radio-RRC:

The output signal for the RTTY keying can also be found in the I/O connector.

Signal	I/O connector	IO setting
RTTY- output	5 (OUT0)	OUT0 mode = Baudot /45
RTTY -output	6 (OUT1)	-
RTTY -output	3 (OUT2)	-
gnd	8	-

The I/O connector can also be used for the PTT signal if the Mic PTT is not used. If you want this function change one of the free outputs to PTT.

ICOM CI-V

General

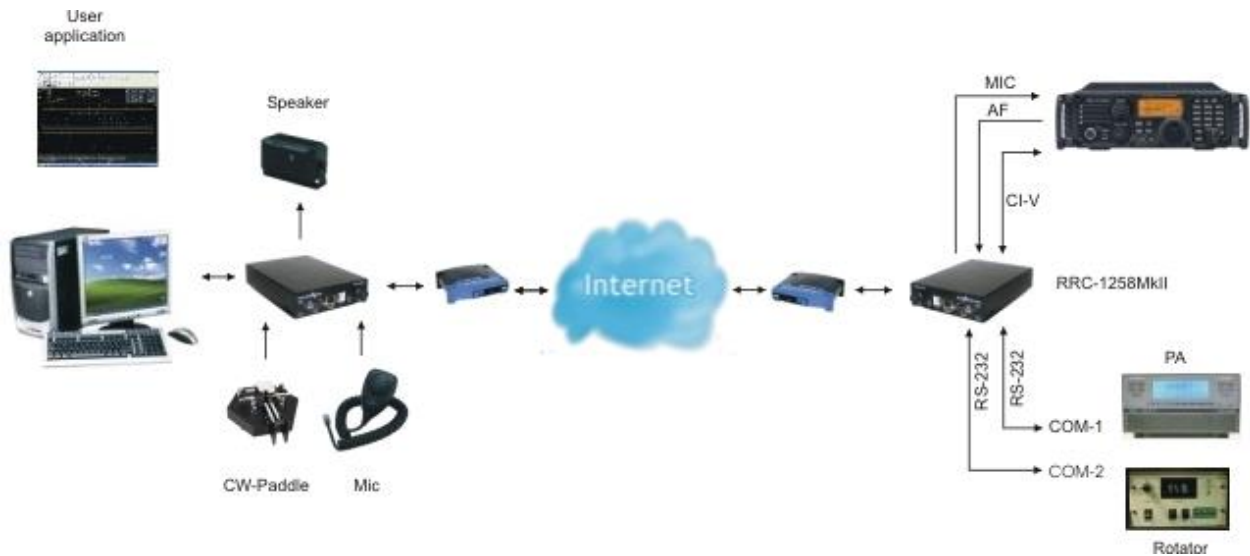

RRC-1258MkII supports the CI-V protocol used by almost every ICOM radio. Then you have to use a PC-software e.g. HamRadioDeLuxe or similar rig control software at the control site. All audio and data communication goes true the RRC:s and you don't need a PC at the remote site. The Connect/Disconnect button on the web status page is used to connect/disconnect to/from the remote site. It can also be done by the UP-button on the microphone or be set to always be connected.

Hardware configuration

Normal:

ICOM gen CI-V

RRC-1258MkII Control		RRC-1258MkII Radio	
	JMP1 DC To Mic	1	
	JMP2 8/9V	1	
	JMP3 RTS-CTS	1	
	JMP5 TTL Pin6	1	

1 = In place, 0 = Not in place, X = doesn't matter

SIP-Connect/disconnect via MIC UP button:

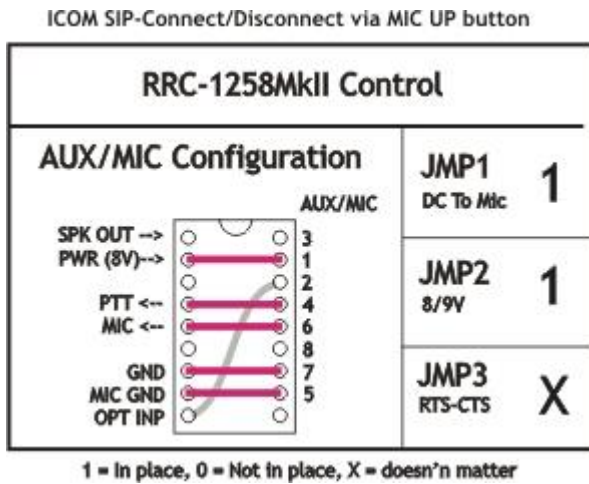

Radio settings (example)

Parameter	Control	Radio
Program mode	1 - ICOM CI-V	1 - ICOM CI-V
SIP password	hello	hello
SIP contact	192.168.0.228	
Auto connect	No	
Audio quality	2 - Linear 16 bits 8 kHz	2 - Linear 16 bits 8 kHz
Audio dual-rx (*)		No
Codec out gain	255	255
Codec inp gain	18	0
Codec inp preamp	Yes	
Codec inp HPF Hz	163	163
COM0 baudrate	9600	9600
COM0 data bits	8	8
COM0 stop bits	1	1
COM0 parity	0 - Off	0 - Off

(*) Available only in RRC-1258MkIIs, remember that the bandwidth demand is doubled.

Connections

Drawings of the connection cables can be found under appendix B.

Control-RRC:

- Connect a Remoterig-I10c cable or a standard RS-232 cable between the PC and the RRC COM2.

- The microphone can be connected direct to the RRC AUX/MIC connector if you have a microphone with RJ-45 connector, like the HM-103. If you have a microphone with a circular connector like HM-36 you have to use the Remoterig I10a cable, the OPC-589, from ICOM or make one by yourself (drawing for I10a is provided).
- The speaker is connected direct to the RRC SP-jack with a 3.5 mm stereo plug.

Radio-RRC:

- From the RRC TTL connector to the radios CI-V jack you can use the Remoterig I11c cable or make it by your self. The cable should have a 4/6 modular connector in one end and a 3.5 mm stereo plug in the other end. The 3.5 mm plug is connected to the radio CI-V jack.
- Between the RRC AUX/MIC connector and the radios microphone jack you can connect a standard patch cable if the radio have a RJ-45 jack. If the radio have a circular microphone jack you can use the Remoterig I11a or make the cable by yourself. (drawings for I11a is provided). Make the cable as short as possible to prevent it from picking up HF.
- The speaker signal from the radios external speaker jack to the RRC SP jack is connected via a standard "off- the-shelf" cable with 3.5 mm stereo plugs in both ends.



I11a,I10a

DET. NR. CONSTR. DRAWN	CNT	NAME	DIMENSION SCALE	NOTE
MS		CHECKED STAND. OK	1:2	REPLACE 091121
		Generic ICOM cables RRC-1258MkII		DATE 110306
				DRAWING NR 1258 Cable I10 1(1)

RRC-1258MkII

8-pol RJ 45 Con

Mic Inp
8-pol Circular
male

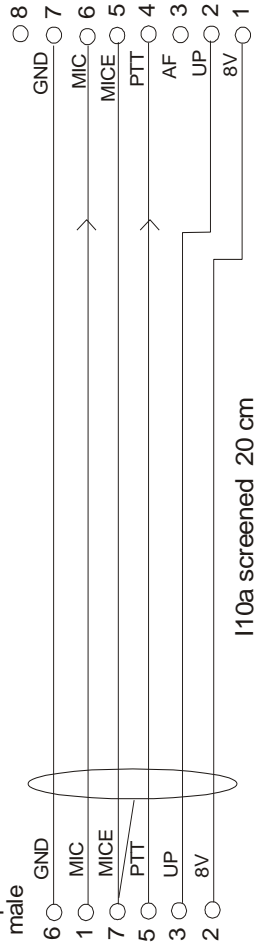
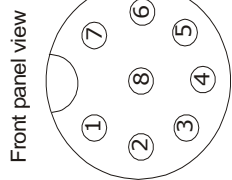
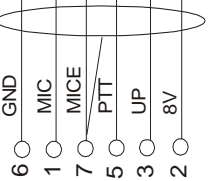

I10a screened 20 cm

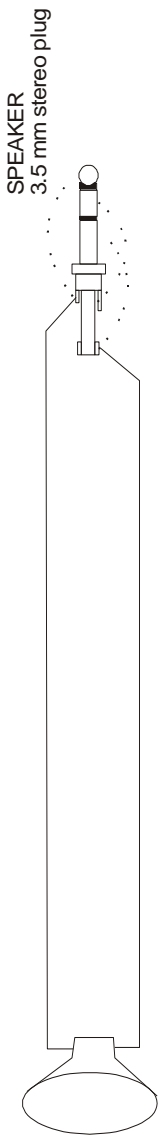
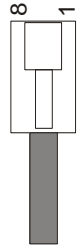

PC

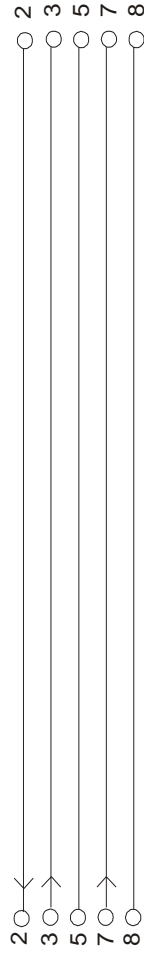

COM2



I10c

DSUB- 9pol
Male

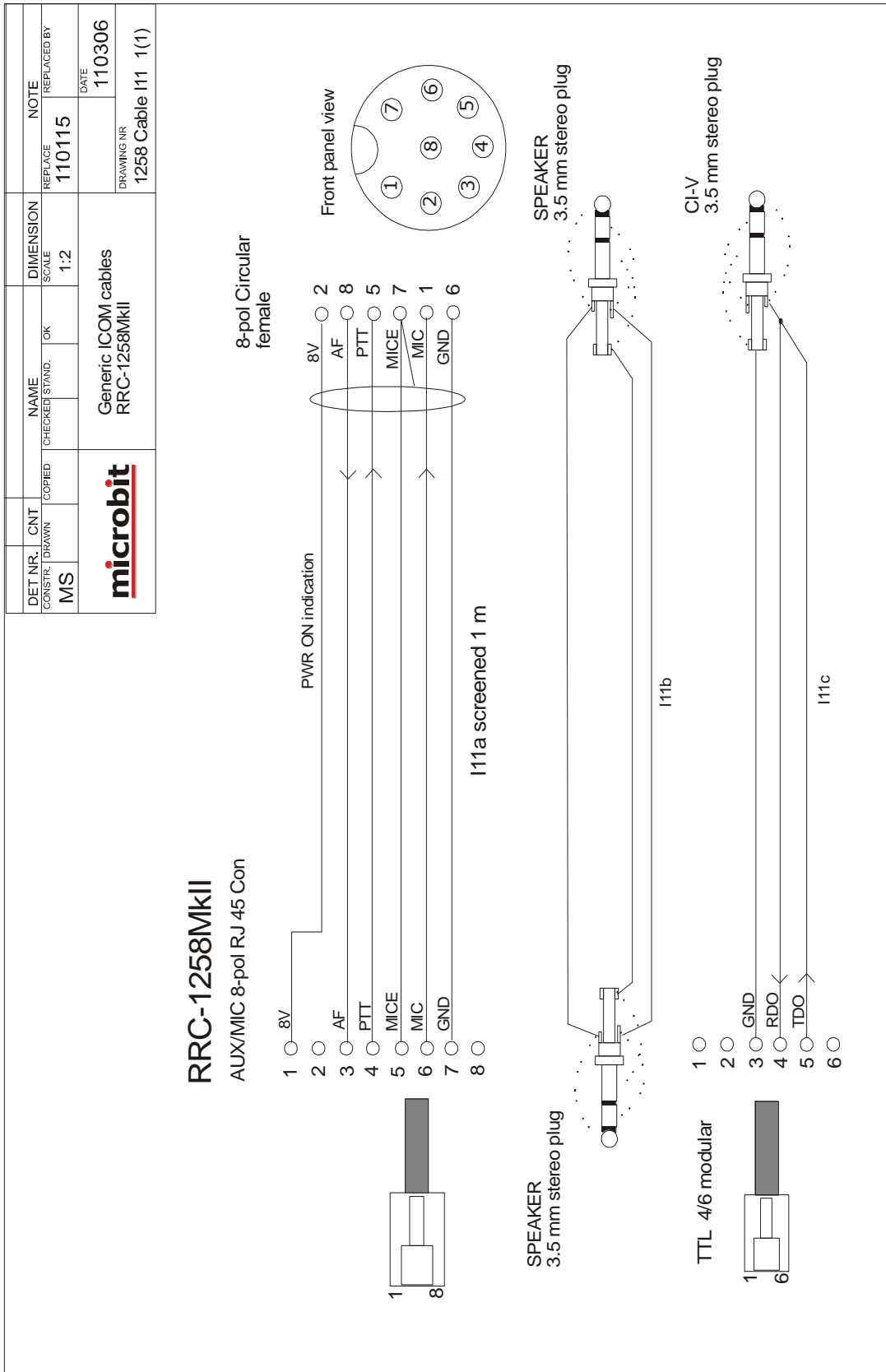

ICOM IC-7100

General

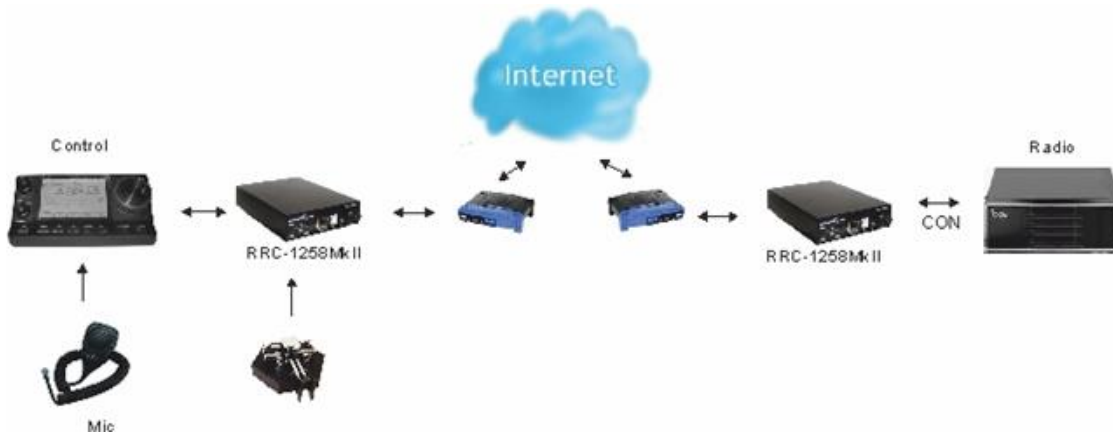

The latest HF/VHF/UHF rig from ICOM are supported by Remoterig. You get full remote functionality from the control panel and the feeling is exactly as if you use them locally. It's one of the simplest rig to setup and come on the air with. No special cables needed, just connect the RJ45:s and setup the parameters in the boxes. When you press the power button on the panel the radio comes to life at the remote side and sound and panel info flows across the Internet between the pair of RRC-1258MkII:s.

Hardware configuration

Unfortunately there are already two versions of the IC-7100. ICOM have made a hardware modification lately (March 2014) which makes later produced rigs incompatible with the original Remoterig boxes (New IC-7100 control panels are also incompatible with old IC-7100 main units). The reason of the modification was to avoid that data communication will be heard in FM mode at low modulation levels. They have solved it by reducing the amplitude of the data sent from control to main unit. To handle this modification in the Remoterig a interface PCB called 1258M has to be installed in the (red) strap socket of the Control-RRC. The Adapter PCB is available at our webshop. It's quite simple so it can be built by yourself also (see hardware mods at the Remoterig website). The Interface 1258M can be used both for early IC-7100 and modified IC-7100

The ICOM modification was done from serial numbers US>02003001 and in EU>03003601.

All red straps are replaced at Control side are replaced by the PCB. When assemble the adapter in the Control-RRC be aware of the direction of the notch.

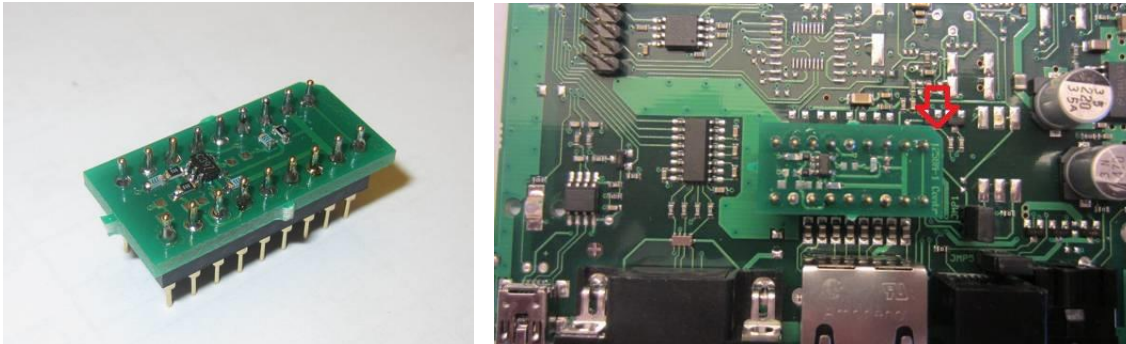

The picture below shows the configuration of the Radio-RRC:s. Note that the picture showing the Control side red straps are only valid for the first version of the IC-7100

IC-7100

RRC-1258MkII Control		RRC-1258MkII Radio	
	JMP1 DC To Mic	1	
	JMP2 8/9V	1	
	JMP3 RTS-CTS	1	
	JMP5 TTL Pin6	1	

1 = In place, 0 = Not in place, X = doesn't matter

Radio settings (example)

Parameter	Control	Radio
Program mode	2 - IC-7100/IC-706/IC-703	2 - IC-7100/IC-706/IC-703
SIP password	hello	hello
SIP contact	192.168.0.228	
Auto connect	No	
Audio quality	2 - Linear 16 bits 8 kHz	2 - Linear 16 bits 8 kHz
Audio dual-rx (*)		No
Codec out gain	255	255
Codec inp gain	18	0
Codec inp preamp	Yes	
Codec inp HPF Hz	163	163
COM0 baudrate	38400	38400
COM0 data bits	8	8
COM0 stop bits	1	1
COM0 parity	0 - Off	0 - Off

(*) Available only in RRC-1258MkIIs.

Connections

All necessary signals between the panel and the radio are connected via the 8 wires in the cable between the control panel and the radio body. The cable is a standard CAT-6 shielded patch cable. We just need to add one cable and connect a RRC-1258MkII in each end. The following signals are represented in the cable.

- 1 8V power to control panel (only when radio is ON)
- 2 PWR SW - power switch, grounding it switch on the radio
- 3 AF - audio to speaker.
- 4 TXD - serial data 38400 bps from radio to panel
- 5 MICE - mic ground
- 6 MIC- mic Signal
- 7 GND
- 8 RXD - serial data 38400 bps from panel to radio

Power supply

Control-RRC:

The Control-RRC is supplied with a common 13,8 V (10-18V) power supply. The display and speaker amplifier needs a lot of power so you need 1A.

Radio-RRC:

The Radio-RRC should be supplied from the same power supply as the radio to avoid humming. Please put a small fuse on the cable if you connect it to a 30 Amp PS output.

Logging, computer control, RRC-Micro, RRC-Nano control

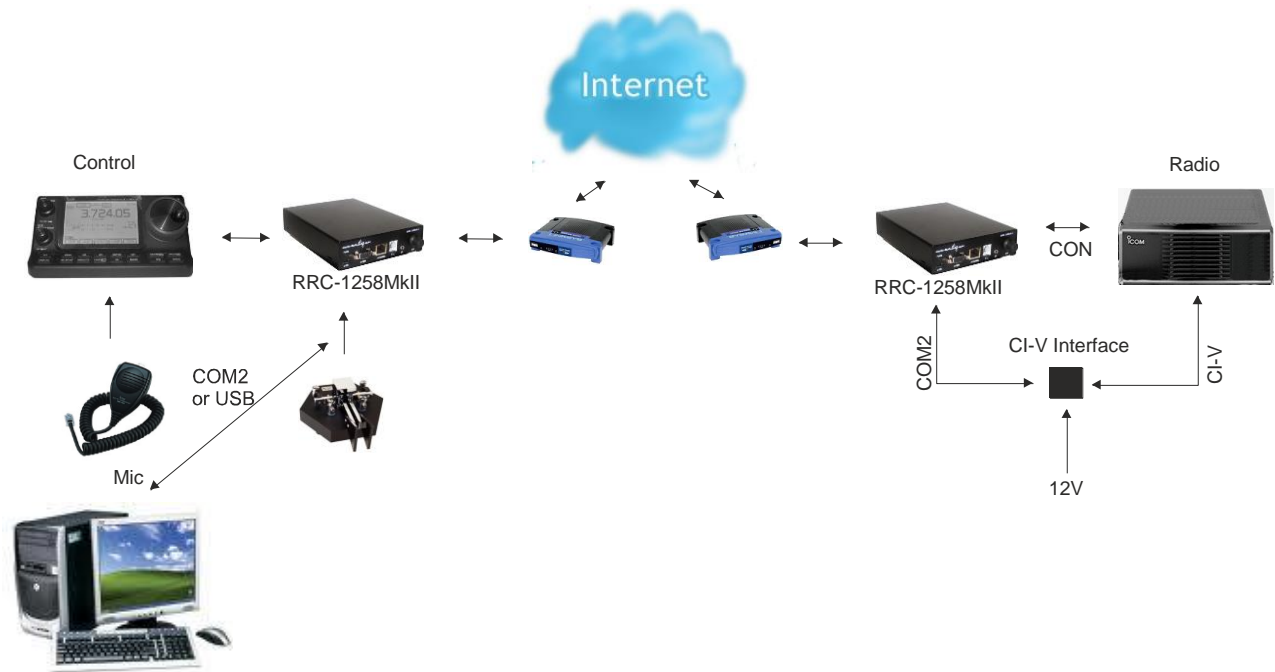

It's common to use a PC logbook software or PC control software connected to the radio, this can be done with the remote controlled IC-7100 also. All PC-programs, the RRC-Micro software and the RRC-Nano App uses the ICOM CI-V protocol to talk to the radio, this protocol is only available via the CI-V jack on the back of the radio. For the connection between the Radio-RRC and the CI-V jack a adapter has to be used. This can be a ICOM-CT17 or the adapter provided by Remoterig (1332-CI-V), Cheap pirate adapters can often not be used as they are built to steal the power from unused pins in a PC RS-232 port, but this is not working with the RRC.



Remoterig Interface 1332-CI-V



ICOM-CT-17

The interface provided by Remoterig is built in into a normal D-sub Housing and provide cables for CI-V, 12V DC-Input and 12V DC output

The picture below show how the Remoterig 1332-CI-V Interface is connected to the IC-7100. It's connected the same way to IC-703 and IC-706.

You remove the 12V DC cable from the RRC and connect it to the 12V DC input cable from the adapter. The 12V DC output cable is then connected to the RRC.

The D-sub is connected to the RRC com2 and the CI-V cable to the CI-V jack on the radio.



Set the radio CI-V baudrate to 9600 baud, this is done from the radio frontpanel. Setup the RRCs to match. If you only want to use RRC-Micro or RRC-Nano only the Radio-RRC settings are needed. You have to decide if you want to use the RS-232 or the USB connector for the connection to the PC (Yes = USB, No = RS-232)

Parameter	Control-RRC	Radio-RRC
COM2 mode	Mode-2 ICOM CI-V	Mode-2 ICOM CI-V
COM2 baudrate	9600	9600
COM2 data bits	8	8
COM2 stop bits	1	1
COM2 parity	0 - Off	0 - Off
Use USB Com Port as COM2	No/Yes	

It's more straightforward to use the Control-RRC physical Com2 on the front of the RRC if you do so you only need to know to which PC com port you connect the cable to when you select com port in your PC-software.

If you USB connection there will show up 4 virtual COM-ports in the Windows Device Manager when you connect the USB-cable. When you open the device manager you will see something like this.

RRC1258 COM0 (COM47)
RRC1258 COM1 (COM49)
RRC1258 COM2 (COM46)
RRC1258 COMExtra (COM48)

The values on within the parentheses is the COM-port number which Windows has assigned to each of the 4 RRC1258 virtual comports.

When you configure your PC program you should select the COM-port which is assigned to RRC1258 COM2, in the example above it's COM46.

ICOM IC-703, IC-706

General



The idea of remote controlling IC-703/706 is simple; it's just to extend the cord between the radio and the control panel using Internet. When you press the power button on the panel the radio comes to life at the remote side and sound and panel info flows across the Internet between the pair of RRC-1258MkII:s. The look and feel of the panel is the same as if the panel was directly connected to the radio.

Hardware configuration

Ic706

RRC-1258MkII Control		RRC-1258MkII Radio	
	JMP1 DC To Mic	1	
	JMP2 8/9V	1	
	JMP3 RTS-CTS	1	JMP3 RTS-CTS
	JMP5 TTL Pin6	1	JMP5 TTL Pin6

1 = in place, 0 = Not in place, X = doesn't matter

Radio settings (example)

Parameter	Control	Radio
Program mode	2 - IC706	2 - IC706
SIP password	hello	hello
SIP contact	192.168.0.228	
Auto connect	No	
Audio quality	2 - Linear 16 bits 8 kHz	2 - Linear 16 bits 8 kHz
Audio dual-rx (*)		No
Codec out gain	255	255
Codec inp gain	18	0
Codec inp preamp	Yes	
Codec inp HPF Hz	163	163
COM0 baudrate	19200	19200
COM0 data bits	8	8
COM0 stop bits	1	1
COM0 parity	0 - Off	0 - Off

(*) Available only in RRC-1258MkIIs.

Connections

All necessary signals between the panel and the radio are connected with the 8 wires in the cable OPC-581 or OPC-587 from ICOM. We just need to cut it apart and connect a RRC-1258MkII in each end. The following signals are represented in the cable, (the numbering is for the RJ45 connector to the RRC after converting the cable, not for the ICOM connector):

- 1 8V power to control panel (only when radio is ON)
- 2 LRXD - serial data 19200 bps from panel to radio
- 3 AF - audio to speaker.
- 4 PWK - power control, grounding it switch on the radio
- 5 MICE - mic ground
- 6 MIC- mic Signal
- 7 GND
- 8 LTXD - serial data 19200 bps from radio to panel

Cut the ICOM cable (OPC-581 or OPC-587) and connect both ends to a standard CAT-5 patch cable for computer networks, use shrinking tubes to protect the soldering. One problem is that the ICOM cable is very soft and there is more sewing tread than copper wire. The copper wire is also varnished to make it even more difficult. Before you connect the cables to the RRC:s, please check the cables by connecting them together with a 2xRJ45 connector. Also pay attention to that a speaker or headset must be connected to the speaker jack on the IC-706 front-panel otherwise the no audio will be sent from the microphone to the radio.

Power supply

Control-RRC:

The Control-RRC is supplied with a common 13,8 V (10-18V) power supply. The display and speaker amplifier needs a lot of power so you need 1A.

Radio-RRC:

The Radio-RRC should be supplied from the same power supply as the radio to avoid humming. Please put a small fuse on the cable if you connect it to a 30 Amp PS.

DET NR.	CNT	NAME		DIMENSION		NOTE	
CONSTR.	DRAWN	CHECKED	STAND.	OK	SCALE	REPLACE	REPLACED BY
MS					1:2		
		Splitted Cable for IC706 RRC 1258 / RRC-1258MkII (CAT-5)				DRAWING NR 1258 Cable 1 1(1)	
		DATE		100609			

Panel

8-pol ICOM-con

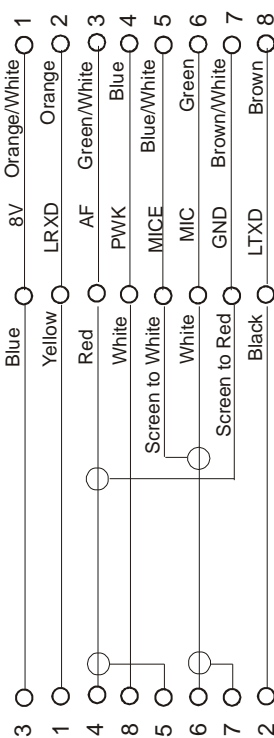

Convert from
ICOM-cable to
8-pol CAT-5 cable

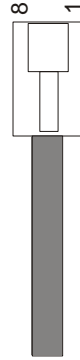

Radio

8-pol ICOM-con

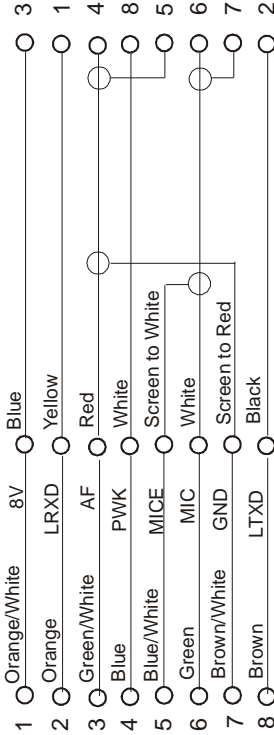

Convert from
ICOM-cable to
8-pol CAT-5 cable

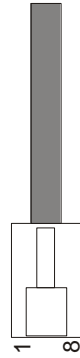

Prepare the separation cable to IC-703 and IC-706



The cable between front and radio before it is cut apart. You have to buy this cable from your local ICOM-dealer (art no OPC-581 or OPC-587).



Connector at radio end.



Connector at control panel end.

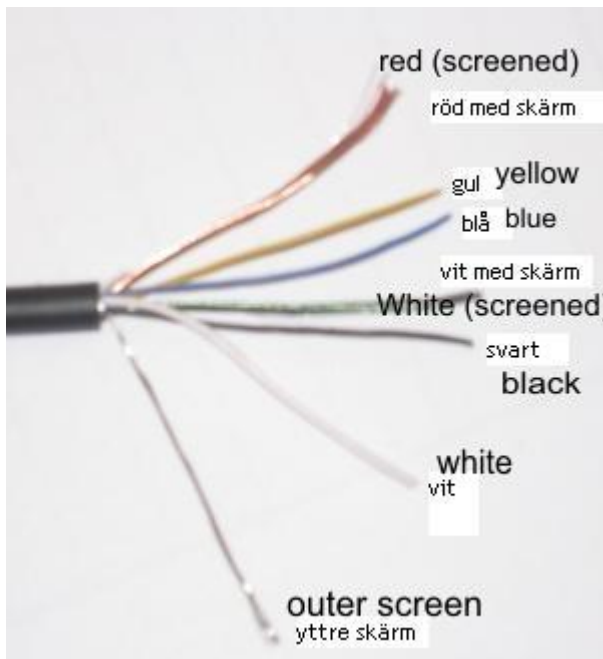

- Identify the end with the connector to the radio, see above.
- Cut the cable apart, don't make it longer than needed at radio end. The mic signal is sensitive of HF from antennas etc. as usually.
- Take away about 40 mm of the outer covering.
- Separate the shields from the inner wire, the red wire has a copper coloured shield and the white has a green shield. The shielded white wire is thinner than the white one without a shielding. That way you can identify them from each other. The outer shielding is not connected to the RRC.
- Cut all wire to about 20 mm. Take away about 3 mm of the cover from each wire and tin-plate them. It's not easy but it's possible.
- Also tin-plate the copper and green shielding.



- Use the supplied CAT-5 cable cut of 10-15 cm from each connector and take away 40 mm of the outer cover.
- Separate the pairs.
- Take away 3 mm of the cover from each wire and tin-plate them.
- Identify the following colours:

1. Orange/White
2. Orange
3. Green/White
4. Blue 5. Blue/White
6. Green
7. Brown/White
8. Brown



- Cut a piece of shrinking tube to each wire. Cut them short enough so they don't shrink from the heat of the solder iron.



- First tread a 100 mm long 6,4 mm shrinking tube on the separation cable.
- Then tread a 80 mm long 6,4 mm shrinking tube on the separation cable.

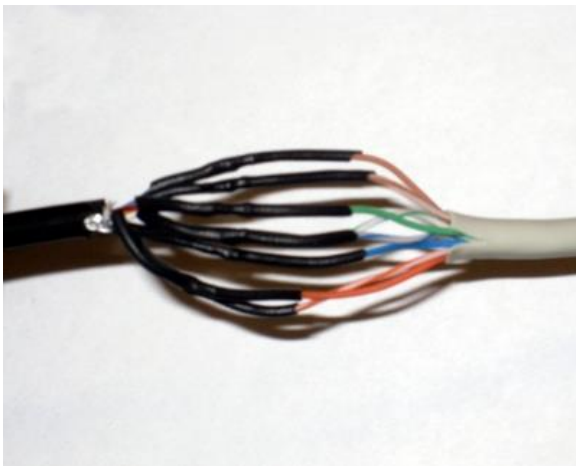

- Solder them together, follow the drawing above.
- Tread the shrinking tubes over the soldered joints and shrink them with hot air.



- Tread the 6.4 mm shrinking tube over the joint and shrink it with hot air.
- Tread the second shrinking tube over the first and shrink them with hot air
- The first cable is now finished, Do the same with the other part. The one with the connector to the control panel.



When you have finished both cables , you can connect them together with a RJ45 extender.

- Check the cable with an ohm-meter. You should have connection from pin 1 at radio end to pin 1 at radio end etc. Also check for short circuits between the pins.
- Connect the cable between panel and radio and check the functionality. Don't forget the microphone. (this should be done without involving the RRC.s at this moment.

When everything is OK you can connect the cables to the RRC:s

ICOM IC-R2500

General

The technical solution is the same as for IC-706 and TS-480; you can remote control the receiver over Internet from the control panel without any PC. We simply replace the cable between the control panel and the receiver with two RRC-1258 units, one at the control panel and one at the receiver. When you push the PWR-ON button an audio and data connection is established between the units and you control the receiver as you do normally with the control panel attached directly to the receiver.

Hardware configuration

IC-R2500

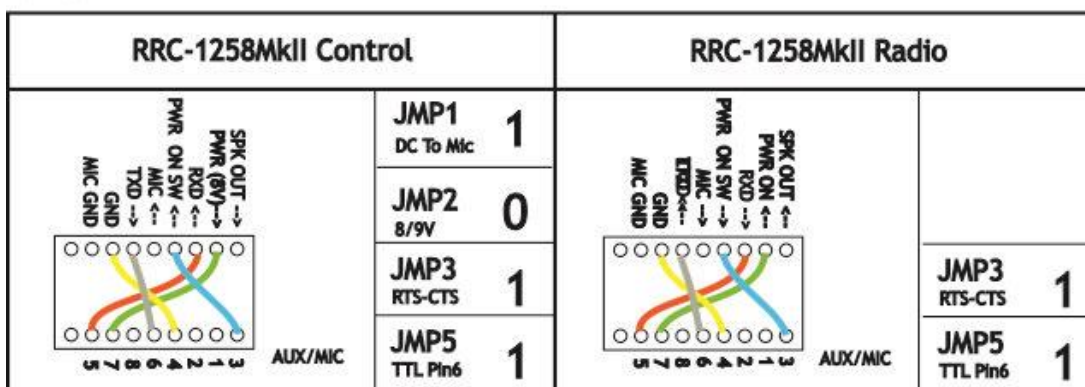

1 = in place, 0 = Not in place, X = doesn't matter

Radio settings (example)

Parameter	Control	Radio
Program mode	7 - ICR2500	7 - ICR2500
SIP password	hello	hello
SIP contact	192.168.0.228	
Auto connect	No	
Audio quality	2 - Linear 16 bits 8 kHz	2 - Linear 16 bits 8 kHz
Audio dual-rx (*)		No/Yes
Codec out gain	255	255
Codec inp gain	18	0
Codec inp preamp	Yes	
Codec inp HPF Hz	163	163
COM0 baudrate	9600	9600
COM0 data bits	8	8
COM0 stop bits	1	1
COM0 parity	0 - Off	0 - Off

(*) Available only in RRC-1258MkIIs, remember that the bandwidth demand is doubled.

Connections

The cabling is quite simple and can be done with simple RJ connectors.

Power supply

Control-RRC:

The Control-RRC is supplied with a common 13,8 V (10-18V) power supply. The display and speaker amplifier needs a lot of power so you need 1A.

Radio-RRC:

The Radio-RRC should be supplied from the same power supply as the radio to avoid humming. Please put a small fuse on the cable if you connect it to a 30 Amp PS.

DET NR.	CNT	NAME		DIMENSION		NOTE	
CONSTR. DRAWN		CHECKED	STAND.	OK	SCALE	REPLACE	REPLACED BY
MS					1:2	091125	
		ICOM cable					
		RRC-1258MkII to IC-R2500 Panel end					
		DRAWING NR		DATE			
		1258 Cable I14		101019			
		1(1)					

Control Panel IC-R2500
6-pol Modular

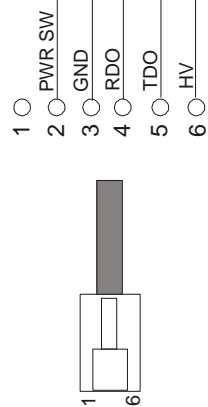

RRC-1258MkII MIC/AUX
8 pol Modular Con

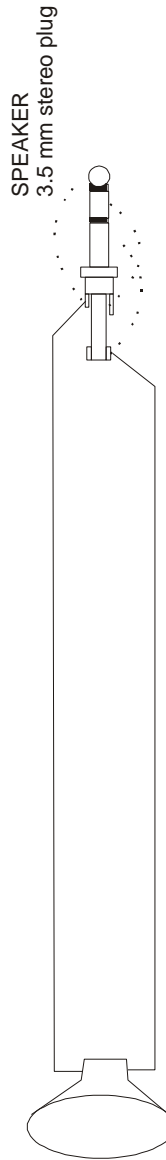
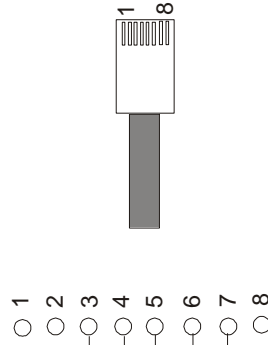

DET NR.	CNT	NAME		DIMENSION	NOTE
CONSTR. DRAWN	CHECKED	STAND.	OK	SCALE	REPLACED BY
MS				1:2	091125
		ICOM cable		RRC-1258MkII to IC-R2500	DATE
		RRC-1258MkII to IC-R2500			101019
DRAWING NR 1258 Cable I15 1(1)					

RRC-1258MkII MIC/AUX
8 pol Modular Con

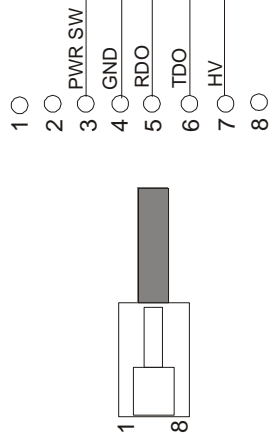

Control Inp IC-R2500
6 pol Modular Con

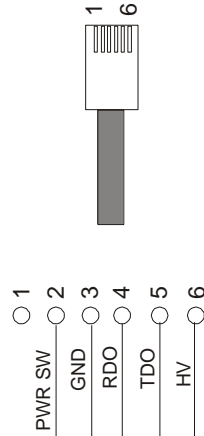

SPEAKER
3.5 mm stereo plug



ICOM IC-E2820

General

It's not only shortwave transceivers which could be remote controlled, the remoterig system also support ICOM:s D-star radio IC-E2820. The technical solution is the same as for IC-706 and TS-480; you can remote control the radio over Internet from the control panel without any PC. We simply replace the cable between the control panel and the radio with two RRC-1258 units, one at the control panel and one at the radio. When you push the PWR-ON button an audio and data connection is established between the units and you control the radio as you do normally with the control panel directly attached to the radio.

Hardware configuration

ICOM IC-2820

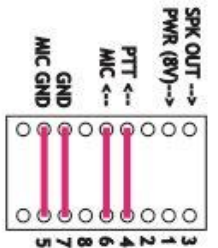
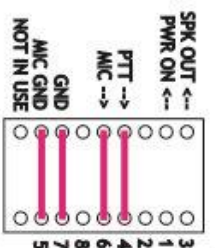
RRC-1258MkII Control		RRC-1258MkII Radio		
	JMP1 DC To Mic	1		
	JMP2 8/9V	1		
	JMP3 RTS-CTS	1		
	JMP5 TTL Pin6	1		
			JMP3 RTS-CTS	1
			JMP5 TTL Pin6	1

1 = In place, 0 = Not in place, X = doesn't matter

Radio settings (example)

Parameter	Control	Radio
Program mode	9 – IC-E2820	9 – IC-E2820
SIP password	hello	hello
SIP contact	192.168.0.228	
Auto connect	No	
Audio quality	2 – Linear 16 bits 8 kHz	2 – Linear 16 bits 8 kHz
Audio dual-rx (*)		No
Codec out gain	255	255
Codec inp gain	18	0
Codec inp preamp	Yes	
Codec inp HPF Hz	163	163
COM0 baudrate	38400	38400
COM0 data bits	8	8
COM0 stop bits	1	1

COM0 parity	0 - Off	0 - Off
-------------	---------	---------

(*) Available only in RRC-1258MkIIs

Connections

The cabling is quite simple and can be done with simple RJ connectors. Be aware of that the original microphone can not be used without the HM-133 adapter boards. If you do not have them use a simple ICOM microphone like HM-103 or HM-95. Microphones with circular connectors can also be used with adapter cable OPC-589.

Control-RRC:

- You have to make the control cable I13a to connect between the Control panel and the RRC TTL connector. Mark up the cable so you connect the connectors to the right unit, it will not work if you try to use it connected backwards.
- The microphone can be connected direct to the RRC AUX/MIC connector if you have a microphone with RJ-45 connector.
- The speaker is connected direct to the RRC SP-jack with a 3.5 mm stereo plug.

Radio-RRC:

- You have to make the control cable I12b to connect between the Radio-RRC and the Radio. Mark up the cable so you connect the connectors to the right unit, it will not work if you try to use it connected backwards.
- Between the RRC AUX/MIC connector and the radios microphone jack you can connect a standard patch cable (CAT5 or CAT6) I12a.
- The speaker signal from the radios external speaker jack to the RRC SP jack is connected via a standard "off- the-shelf" cable with 3.5 mm stereo plugs in both ends.

Using HM-133 Microphone

If you have a RRC-1258MkIIIs you can buy the HM-133 adapter pcbs which let you use the HM-133 microphone with all it's buttons.

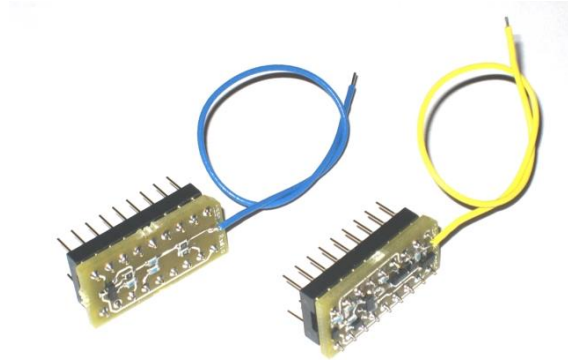

The small pcbs are mounted in the strapping sockets which means that no red straps are needed. The pcb with the yellow cable are mounted in the Control-RRC and the pcb with the blue cable are mounted in the Radio-RRC. The yellow and blue cables need to be solder to one point on the RRC pcb. See pictures below. Be sure to remove power when solder. There No settings need to be changed after mounting the pcbs.



There is one solder pad which is significantly bigger than the other via holes to the right of the CPU over the Crystal. That's the one which the cables should be soldered to.

Control-RRC

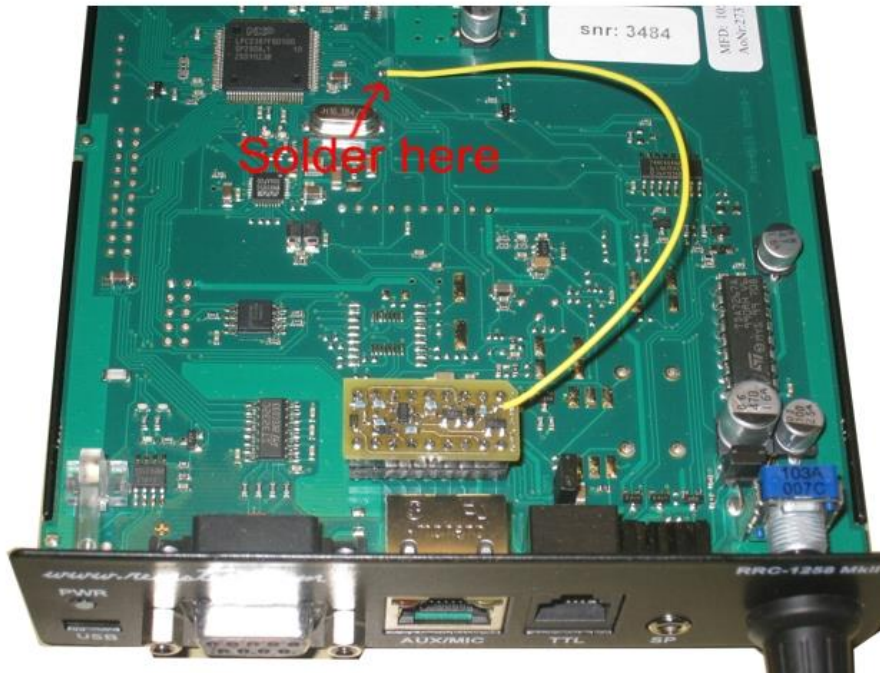

Radio-RRC

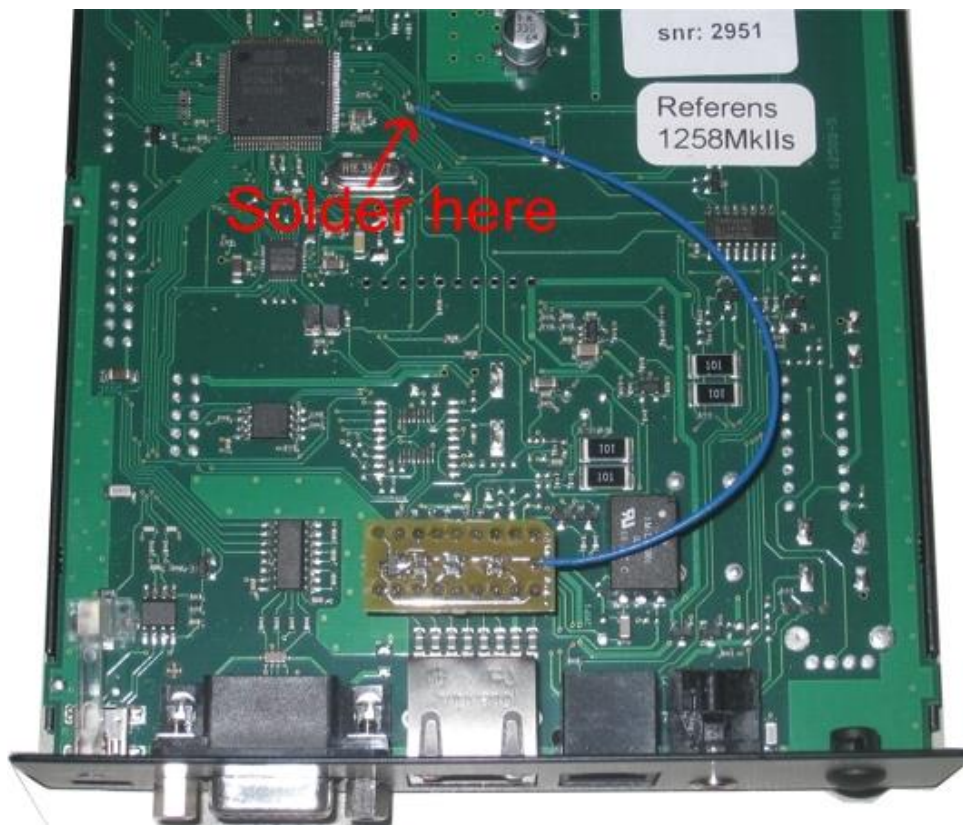

Power supply

Control-RRC:

The Control-RRC is supplied with a common 13,8 V (10-18V) power supply. The display and speaker amplifier needs a lot of power so you need 1A.

Radio-RRC:

The Radio-RRC should be supplied from the same power supply as the radio to avoid humming. Please put a small fuse on the cable if you connect it to a 30 Amp PS.

DET NR.	CNT	NAME		DIMENSION		NOTE	
CONSTR.	DRAWN	CHECKED	STAND.	OK	SCALE	REPLACE	REPLACED BY
MS					1:2	091005	
		ICOM cable				DATE	
		RRC-1258MkII to IC-2820				091125	
		Panel end				DRAWING NR	
						1258 Cable I13 1(1)	

Control Panel IC-E2820

4-pol Modular

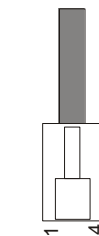

RRC-1258MkII TTL

4/6 pol Modular Con

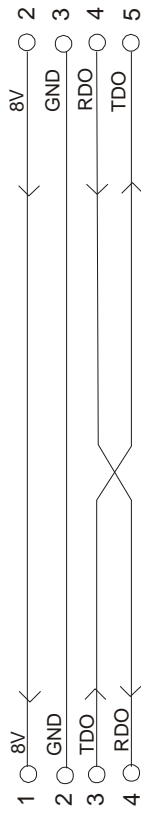

I13a

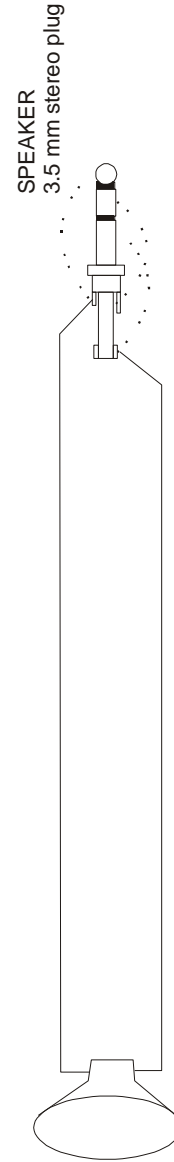

DET NR.	CNT	NAME	DIMENSION	NOTE
CONSTR.	DRAWN			
MS		CHECKED STAND.	1:2	091125
		ICOM cable	RRC-1258 to ICOM IC-E2820	DATE
		RRC-1258 to ICOM IC-E2820		110615
		Radio end	DRAWING NR	1258 Cable I12 1(1)

RRC-1258MkII
8-pol RJ 45 Con

Try Standard shielded CAT 5

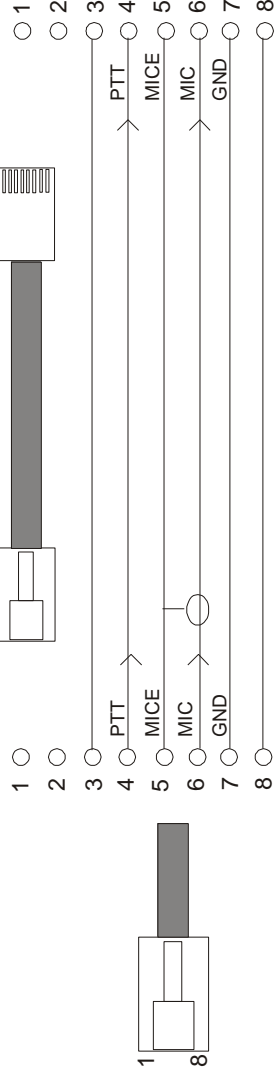
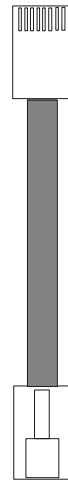

Mic Inp IC-E2820
8-pol RJ 45 Con



I12a

RRC-1258MkII
4/6 pol Modular Con

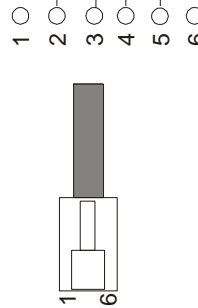

Control Inp IC-E2820
4/6 pol Modular Con



I12b

SPEAKER
3.5 mm stereo plug

SPEAKER
3.5 mm stereo plug



ICOM ID-E880

General

The Remoterig system also support ICOM:s D-star radio ID-E880. The technical solution is the same as for IC-706, IC-7100, TS-480 etc. You can remote control the radio over Internet from the control panel without any PC. We simply replace the cable between the control panel and the radio with two RRC-1258 units, one at the control panel and one at the radio. When you push the PWR-ON button an audio and data connection is established between the units and you control the radio as you do normally with the control panel directly attached to the radio.

Hardware configuration

If you have a RRC with hardware v7 or later the setup is simple, for hardwares before v7 the preparations is a little bit more complicated for the IC-E880 as some modifications must be done at the Remoterig circuit boards, Check Mods on the website under support. In both cases the HM-133 adapters must be mounted and a wire must be connected, more info below.

Radio settings (example)

Parameter	Control	Radio
Program mode	13 - IC-E880	13 - IC-E880
SIP password	hello	hello
SIP contact	192.168.0.228	
Auto connect	No	
Audio quality	2 - Linear 16 bits 8 kHz	2 - Linear 16 bits 8 kHz
Audio dual-rx (*)		No
Codec out gain	255	255
Codec inp gain	18	0
Codec inp preamp	Yes	
Codec inp HPF Hz	163	163
COM0 baudrate	38400	38400
COM0 data bits	8	8
COM0 stop bits	1	1
COM0 parity	0 - Off	0 - Off

(*) Available only in RRC-1258MkIIs

Jumpers

Control-RRC:

JMP 1 = Yes
JMP 2 = Yes
JMP 3 = don't care
JMP 5 = No

Radio-RRC:

JMP 3 = don't care
JMP 5 = No

Connections

The cabling is quite simple and can be done with simple RJ connectors. Be aware of that the HM-133/880 adapter boards must be used

Drawings of the connection cables can be found below.

Control-RRC:

- You have to make the control cable I22b to connect between the Control panel and the RRC TTL connector. Mark up the cable so you connect the connectors to the right unit, it will not work if you try to use it connected backwards.
- The microphone can be connected direct to the RRC AUX/MIC connector if you have a microphone with RJ-45 connector.
- The speaker is connected direct to the RRC SP-jack with a 3.5 mm stereo plug.

Radio-RRC:

- You have to make the control cable I21b to connect between the Radio-RRC and the Radio. Mark up the cable so you connect the connectors to the right unit, it will not work if you try to use it connected backwards.
- Between the RRC AUX/MIC connector and the radios microphone jack you can connect a standard patch cable (CAT5 or CAT6).
- The speaker signal from the radios external speaker jack to the RRC SP jack is connected via a standard "off- the-shelf" cable with 3.5 mm stereo plugs in both ends.

HM-133/880 Microphone adapter boards

If you have a RRC-1258MkIIs you can buy the HM-133/880 adapter pcbs which are needed for the function together with the IC-E880.

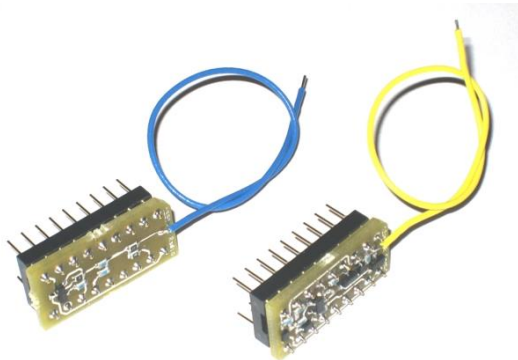

The small pcbs are mounted in the strapping sockets which means that no red straps are needed. The pcb with the yellow cable are mounted in the Control-RRC and the pcb with the blue cable are mounted in the Radio-RRC. The yellow and blue cables need to be solder to one point on the RRC pcb. See pictures below. Be sure to remove power when solder. There is no settings that need to be changed after mounting the pcbs.



There is one solder pad which is significantly bigger than the other via holes to the right of the CPU over the Crystal. That's the one which the cables should be soldered to.

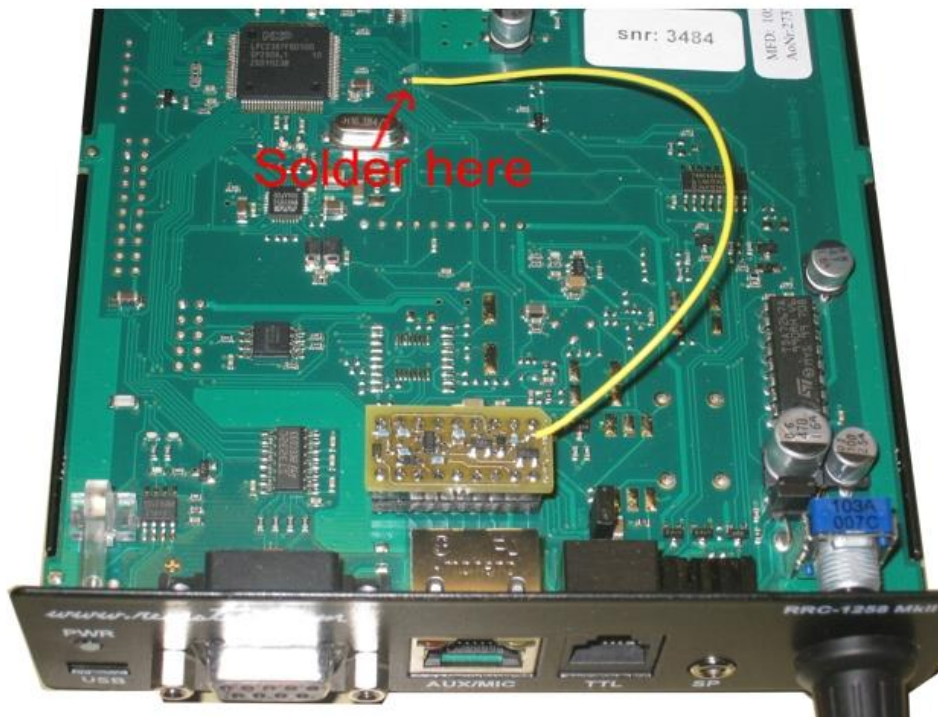

Control-RRC

Radio-RRC

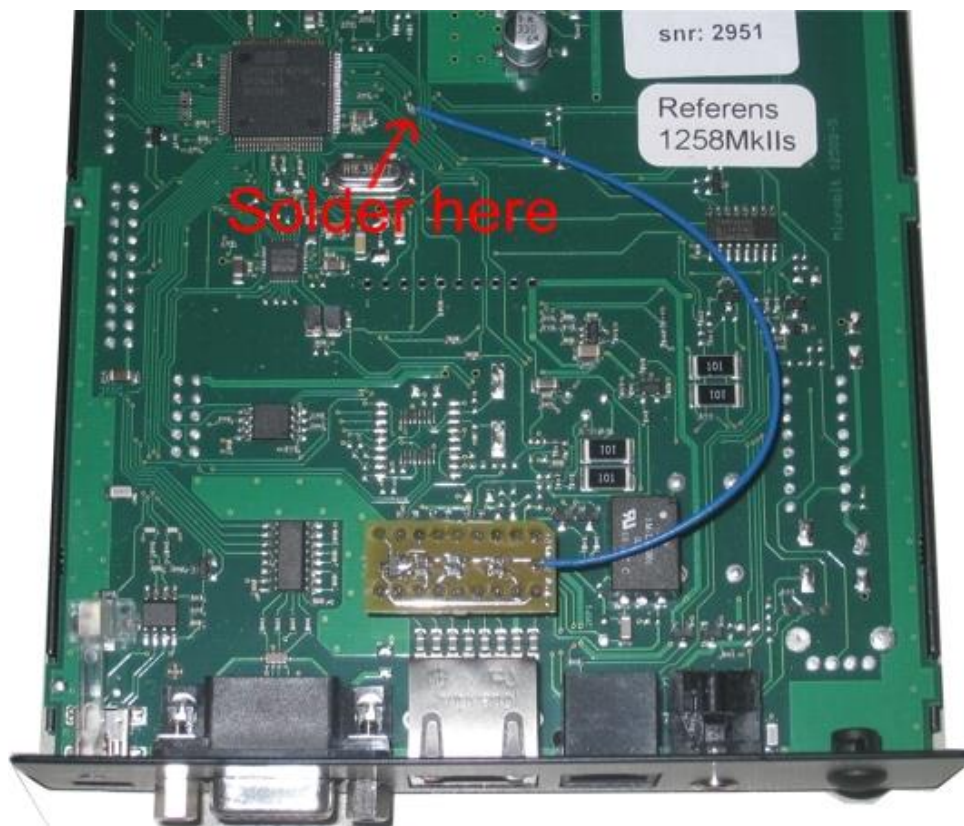

Power supply

Control-RRC:

The Control-RRC is supplied with a common 13,8 V (10-18V) power supply. The display and speaker amplifier needs a lot of power so you need 1A.

Radio-RRC:

The Radio-RRC should be supplied from the same power supply as the radio to avoid humming. Please put a small fuse on the cable if you connect it to a 30 Amp PS.

DET NR.	CNT	NAME	DIMENSION	NOTE
CONSTR.	DRAWN	CHECKED/ STAND.	SCALE	REPLACE
MS			1:2	REPLACED BY
			ICOM cable RRC-1258MkII to ID-E880 Panel end, RRC v7	DATE
				120309
DRAWING NR 1258 Cable I22 1(1)				

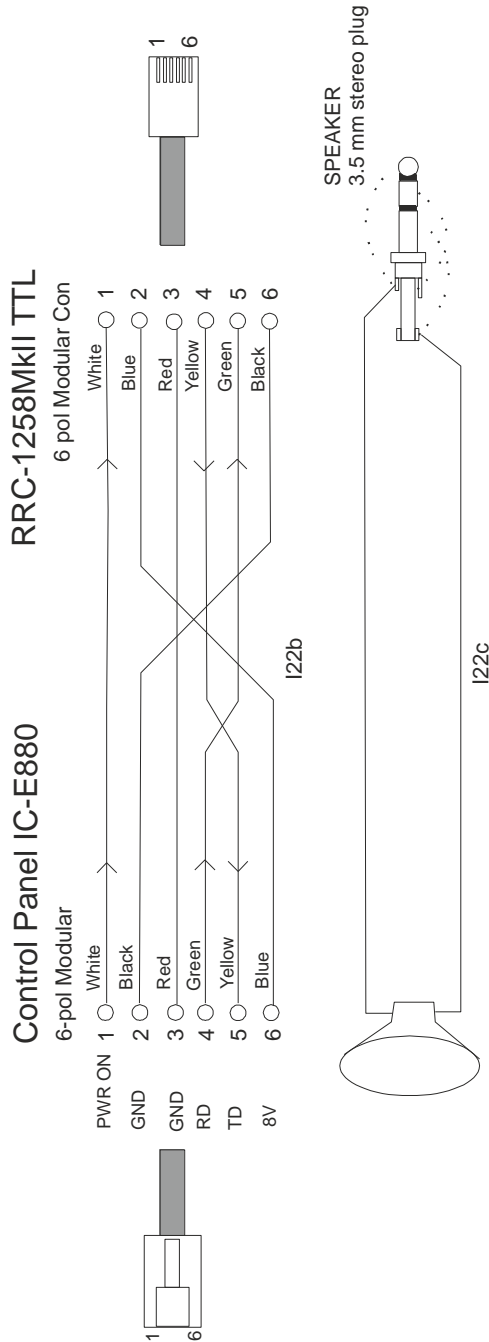

Radio settings (example)

Parameter	Control	Radio
Program mode	7 - ICR2500/IC-2725	7 - ICR2500/IC-2725
SIP password	hello	hello
SIP contact	192.168.0.228	
Auto connect	No	
Audio quality	2 - Linear 16 bits 8 kHz	2 - Linear 16 bits 8 kHz
Audio dual-rx (*)		No/Yes
Codec out gain	255	255
Codec inp gain	18	0
Codec inp preamp	Yes	
Codec inp HPF Hz	163	163
COM0 baudrate	9600	9600
COM0 data bits	8	8
COM0 stop bits	1	1
COM0 parity	0 - Off	0 - Off

(*) Available only in RRC-1258MkIIs, remember that the bandwidth demand is doubled.

Connections

The cabling is quite simple and can be done with simple RJ connectors.

Power supply

Control-RRC:

The Control-RRC is supplied with a common 13,8 V (10-18V) power supply. The display and speaker amplifier needs a lot of power so you need 1A.

Radio-RRC:

The Radio-RRC should be supplied from the same power supply as the radio to avoid humming. Please put a small fuse on the cable if you connect it to a 30 Amp PS.

DET NR.	CNT	NAME		DIMENSION		NOTE	
CONSTR. DRAWN		CHECKED	STAND.	OK	SCALE	REPLACE	REPLACED BY
MS					1:2		
		ICOM cable				DATE	
		RRC-1258MkII to IC-2725				110213	
		Panel end				DRAWING NR	
						1258 Cable 18 1(1)	

Control Panel IC-2725
6-pol Modular

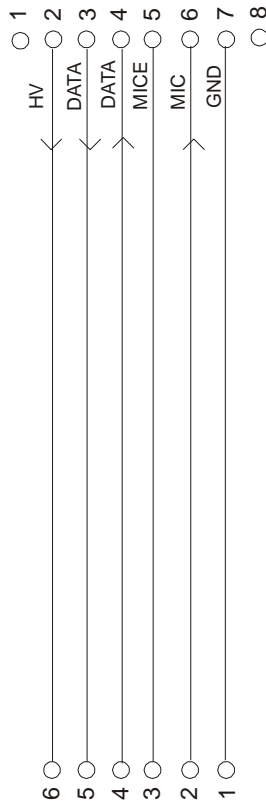

RRC-1258MkII MIC/AUX
8-pol Modular Con

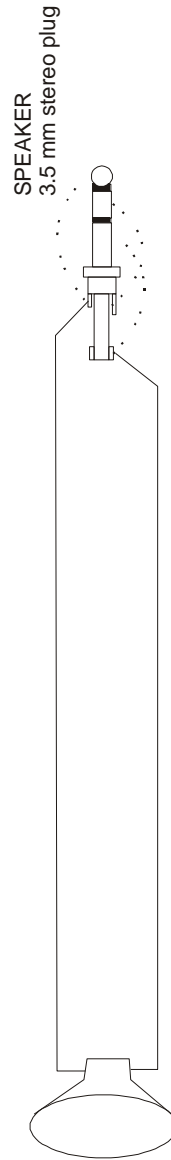

DET NR.	CNT	NAME		DIMENSION		NOTE	
CONSTR.	DRAWN	CHECKED	STAND.	OK	SCALE	REPLACE	REPLACED BY
MS					1:2		
		ICOM cable				DATE	
		RRC-1258MkII to IC-2725				110213	
		Radio end				DRAWING NR	
						1258 Cable I17 1(1)	

RRC-1258MkII MIC/AUX
8 pol Modular Con

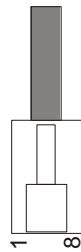
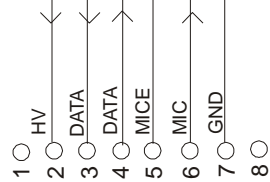

Control Inp IC-2725
6 pol Modular Con

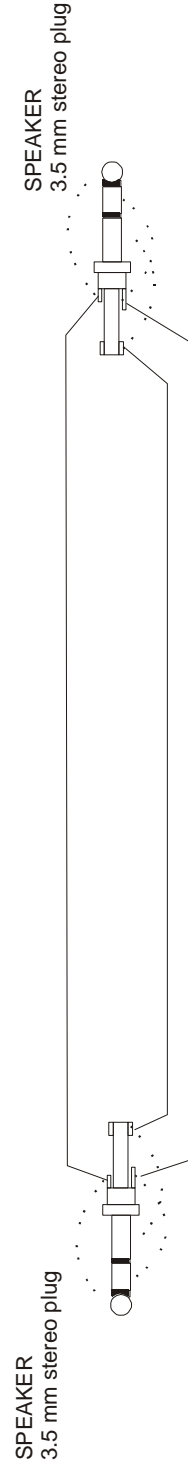
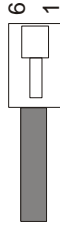

YAESU TWIN

General

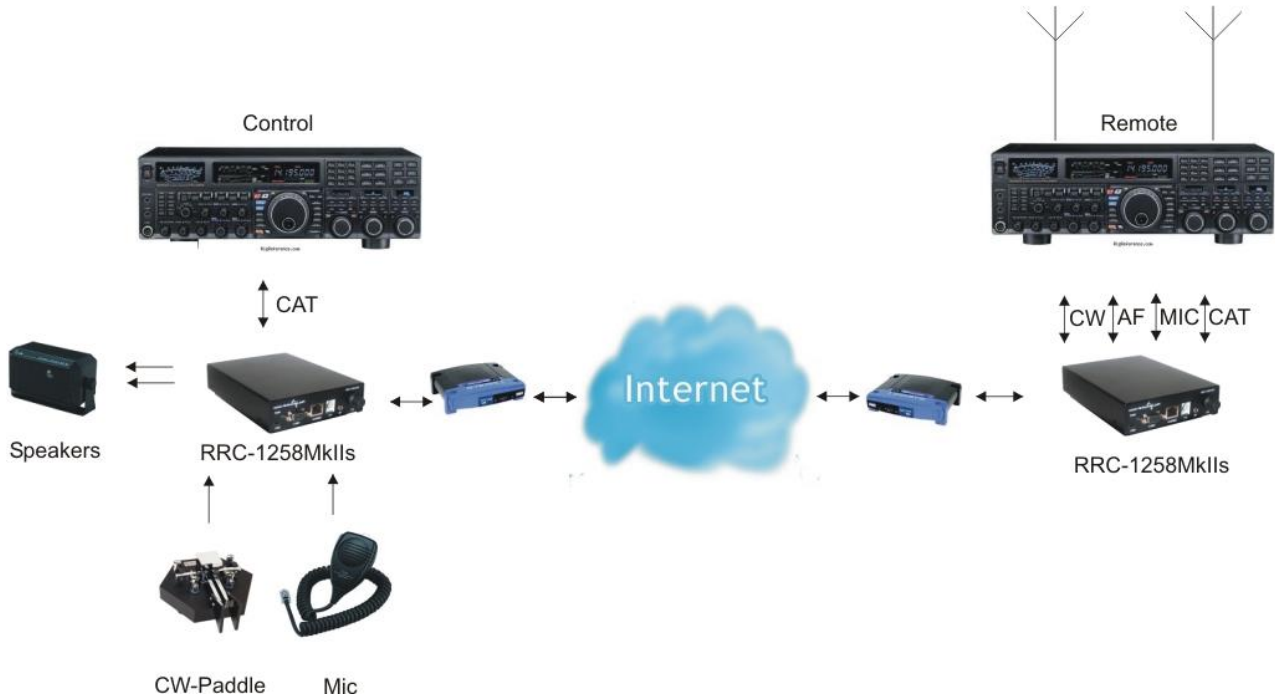

RRC-1258MkIIs Yaesu Twin supports the special high end concept where one Yaesu radio can be used to control another Yaesu radio. No PC:s needed at either end. The RRC-1258MkIIs Yaesu Twin package includes power supplies and all necessary cables. The boxes do not need to be opened all strappings are done in production. All you need to do is to put the system together and do the IP-settings.

The twin concept is mainly developed for using with two radios of the same model for example two FT-5000, but two different models can also be used. The following combinations of are tested:

Control	Radio
FT-450	FT-450
FT-950	FT-950
FT-950	FT-5000
FT-2000	FT-2000
FT-2000	FT-5000
FT-5000	FT-5000
FT-5000	FT-9000
FT-9000	FT-5000
FT-9000	FT-9000

In the combinations tested above all functions works and are tested by several test pilots, anyway we cannot give any guaranties that we have not missed some minor function. The meter functions in the FT-950 have some limitations, the PWR, SWR and ALC are replicated to

the controlling radio but there is no scale marks on the meters so you have to learn how the different values are represented. For the FT-9000 – FT-9000 the sub RX must be active for the ALC meter to work, and of course the spectrum scope does not work remotely.

Attention!

If you want to use the Auto tuner on the Remote radio, it’s very important that you connect dummy loads to the corresponding antenna ports on the control radio. As the radio do not use full power when tuning and it’s done relatively fast, small and cheap 10-20W dummy loads can be used (not included).

Hardware configuration

In the standard RRC:s the strappings are done manually by the customer, but In the RRC-1258MkII's Yaesu Twin package the strappings are done by a small pcb marked 1258Y which is assembled at the strapping area. The small pcb is removable if you later want to use the RRC:s for some other configuration. When you replace it is important that the notch which marks pin one is placed according to the picture below.



For your reference the picture below shows how the strappings are done on the small pcb.

Yaesu

RRC-1258MkII Control		RRC-1258MkII Radio	
AUX/MIC Configuration 	JMP1 DC To Mic 0	AUX/MIC Configuration 	
	JMP2 8/9V 1		JMP3 RTS-CTS 1
	JMP3 RTS-CTS 1		JMP5 TTL Pin6 1
	JMP5 TTL Pin6 1		

1 = In place, 0 = Not in place, X = doesn't matter

Radio settings (example)

Parameter	Control	Radio
Program mode	10 – Yaesu FT-450/950/2K/5K/9K twin	10 – Yaesu FT-450/950/2K/5K/9K twin
SIP password	hello	hello
SIP contact	192.168.0.228	
Auto connect	No	
Audio quality	2 – Linear 16 bits 8 kHz	2 – Linear 16 bits 8 kHz
Audio Dual-RX	-	Yes (*1)
Codec out gain	255	255
Codec inp gain	18	0
Codec inp preamp	Yes	
Codec inp HPF Hz	163	163
COM0 baudrate	38400(*2)	38400(*2)
COM0 data bits	8	8
COM0 stop bits	1	1
COM0 parity	0 – Off	0 – Off

(*1) Remember that the bandwidth demand is doubled if Dual-RX is activated.

(*2) Set the CAT speed in both Radios to 38400 baud, and set RTS to No

Connections

Drawings of the connection cables can be found below.

All necessary cables are included in the package.

Control site



- 1 Connect 12V power supply to the PWR jack
- 2 Connector Ethernet to the Ethernet jack (2m CAT 5 cable included)
- 3 Connect the CAT cable Y5d from the COM2 connector to the radio CAT connector
- 4 Connect the microphone via the Microphone adapter cable Y5a
- 5 Connect speaker to the speaker jack (speakers and cable are not included)
- 6 Connect paddle to the PAD jack (adapter from ¼" connector to 3.55 mm included)
- 7 Connect a dummy to the headset jack on the transceiver to quiet the Internal speaker.
- 8 Connect Dummy loads to the Antenna jacks (not included)

Radio site



- 1 Connect 12V power supply to the PWR jack
- 2 Connector Ethernet to the Ethernet jack (2m CAT 5 cable included)
- 3 Connect the CAT cable Y6d from the COM2 connector to the radio CAT connector
- 4 Connect the mic cable Y6a from the AUX/MIC jack to the radio mic connector.
- 5 Connect the audio cable from to the SP jack to the radio headphone output. (Adapter from ¼" connector to 3.5 mm included)
- 6 Connect the keying cable from the PAD jack to the radio key input (Adapter from ¼" connector to 3.55 mm included)

Logging or computer control, RTTY etc.

Even if the CAT connector at the Remote Radio is occupied with the communication between the two Radios it is possible to connect other equipment to the system due to an intelligent CAT server functionality in the RRC.s. If you need to connect a antenna switch for example which need to talk to the remote Radio you can connect it to the Radio-RRC COM1 and configure COM1 to "Mode 6, CAT to COM2 (local)".

If you want to connect a logging or PC-control software to the system you can connect it to the Control-RRC COM1 via RS-232 or USB and configure both RRC:s COM1 to "Mode-6, CAT to COM2 (local)". You can still use the remote antenna switch as described above.

Independent of the connections above you can use the Remote Radios FSK transmission. Configure Radio-RRC "OUT1 mode = Baudot/45" and use the Virtual USB port Extra for the RTTY software.

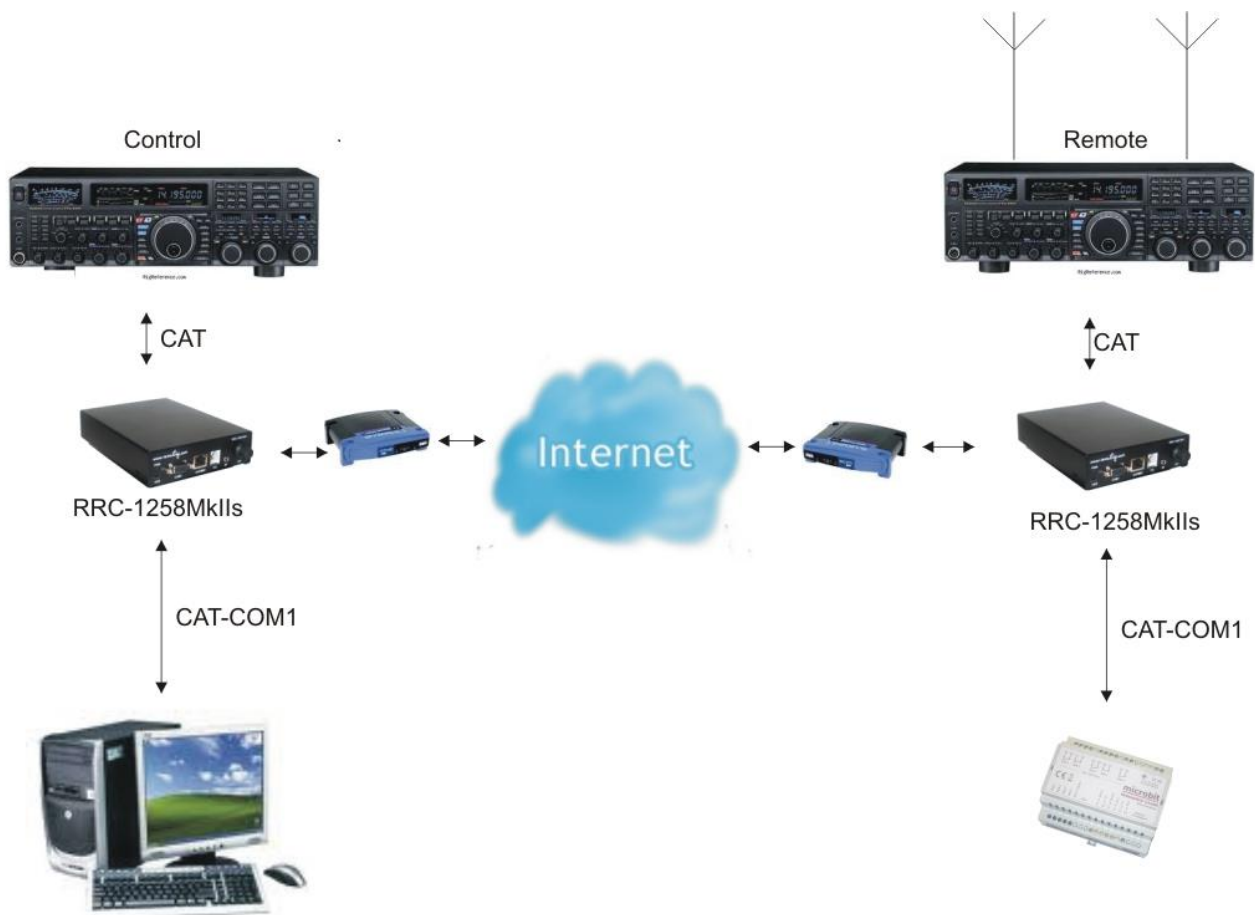



Cable Y5d – Control Radio to Control-RRC COM2



Cable Y6d – Radio-RRC to Remote Radio COM2



Cable Y5a – Mic to Control-RRC Mic jack



Cable Y6a – Radio-RRC Mic jack to Radio Mic input



Cable 3.5 mm – 3.5 mm Audio Output from Remote radio to Radio-RRC SP input jack



Cable 3.5 mm – 1/4 inch Keyer from Radio-RRC PAD jack to Remote radio straight key input jack



Adapter 1/4" to 3.5 mm Headset adapter



Adapter 1/4" to 3.5 mm Paddle adapter



Adapter 3.5 mm to 1/4" Headset output
adapter from remote remote radio

Control-RRC:

- Connect the RS-232 cable Y5d between the Control-RRC COM2 and the CAT connector on the Radio.
- The microphone can be connected direct to the RRC AUX/MIC connector if you have a microphone with RJ-45 connector. If you have a microphone with a circular connector use the adapter cable Y5a.
- The speaker is connected direct to the RRC SP-jack with a 3.5 mm stereo plug.
- Paddles are connected to the PAD jack. If you the paddles have a 1/4" plug on your paddle use the supplied 1/4" to 3.5 mm adapter cable.
- Connect the CAT 5 cable from the Ethernet jack to your switch or router
- Connect the 12V power supply to the DC jack

Radio-RRC:

- Connect the RS-232 cable Y6d from the Radio-RRC COM2 connector to the radios CAT connector.

- Connect the mic cable Y6a from the Radio-RRC AUX/MIC connector to the radios microphone jack.
- Connect the speaker signal from the radios headset output jack or similar to the Radio-RRC SP jack with the standard 3.5 mm – 3.5 mm cable with stereo plugs in both ends. If the radio have a ¼" jack use the supplied adapter ¼" to 3.5mm.
- Connect keyer cable (standard 3.5 mm – 3.5 mm cable with stereo plugs in both ends) from the Radio-RRC PAD jack to the straight key input jack on the Radio. If the radio have a ¼" jack, use the supplied 3.5 mm to ¼" adapter.
- Connect the CAT 5 cable from the Ethernet jack to your switch or router
- Connect the 12V power supply to the DC jack

DET NR.	CNT	NAME	DIMENSION	NOTE
CONSTR. DRAWN	CHECKED	STAND. OK	SCALE	REPLACE
MS			1:2	100525
		YAESU TWIN Cables RRC-1258MkII to Radio (twin Control side)		
		DRAWING NR	DATE	
		1258 Cable Y5 1(1)		

RRC-1258MkII
8-pol RJ 45 Con

Mic Inp
8-pol Circular

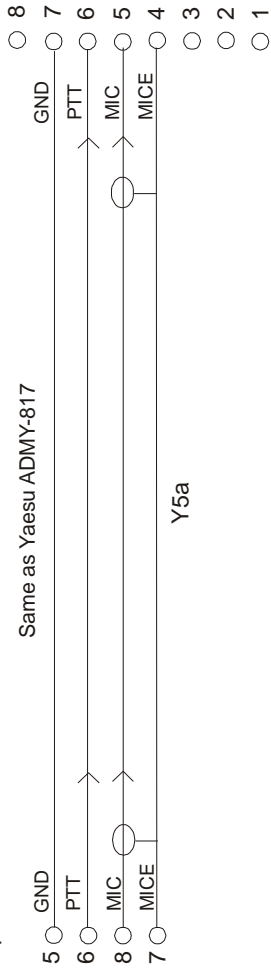
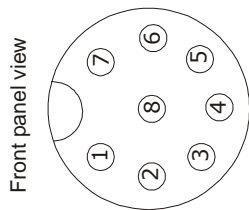

FT-950/2000/5000/9000
CAT port

RRC-1258MkII

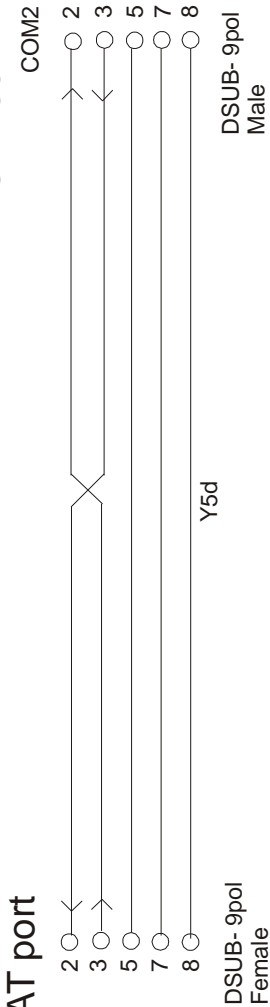

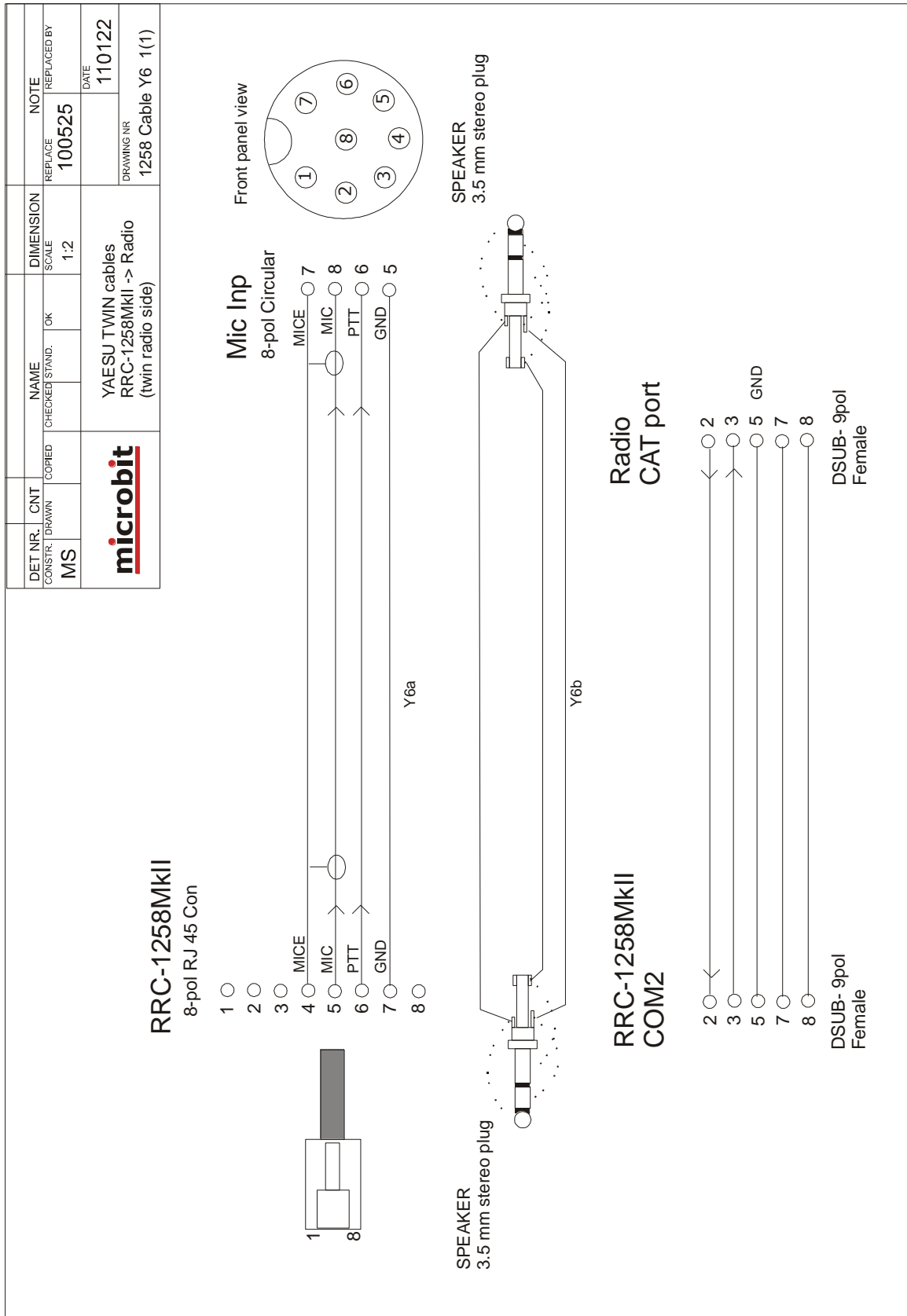

YAESU FT-857

General

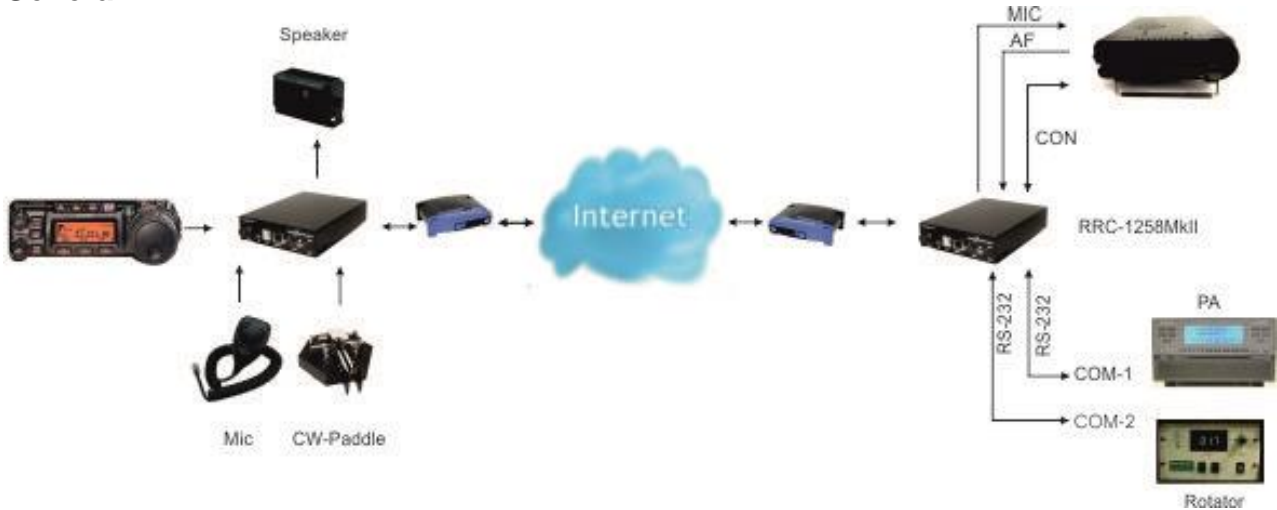

The Remoterig system supports the popular Yaesu FT-857. The technical solution is the same as for all the other rigs like IC-706 and TS-480 etc with detachable control panel. You can remote control the radio over Internet from the control panel without any PC. We simply replace the cable between the control panel and the radio with two RRC-1258 units, one at the control panel and one at the radio. When you push the PWR-ON button an audio and data connection is established between the units and you control the radio as you do normally with the control panel directly attached to the radio.

Hardware configuration

The FT-857 is fully supported by the Remoterig RRC-1258MkIIs from hardware version 7. Earlier version of the RRC:s can also be used but then some hardware changes or special cabling are needed, See at the website under Support and Mods.

If you have a set of RRC:s hardware 7 or later you only need to make cables. The cables are also available from the web shop.

Attention !

The FT-857 can enter a state where it's absolutely unreachable until you remove the 13.8V Power source. Reset of the RRC doesn't help, even physical disconnect of the RRC doesn't help. This happens rarely but if you have the radio on a QTH where you have no one who can switch off the power supply you must install a remote controlled switched so you can switch off the 13,8V power to the radio. For example a Webswitch 1216H, or a GSM Switch, If you do no use all outputs on the RRC-1258 you can use one of the outputs to control a relay which can switch off the 13.8V power to the Radio.

Also be aware of that the FT-857 almost makes a short circuit to the 13.8V power for a short moment when it's powered ON. If you have the Radio-RRC connected to the same Power Supply it can cause the RRC do reset. If it's the case power the RRC-from a separate PS. This

can happen even with some 25A power supplies. You will see if the RRC reset by watching the PWR LED, or checking the Uptime in the web interface.

Yaesu FT-857 HW > 6

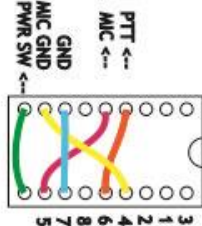
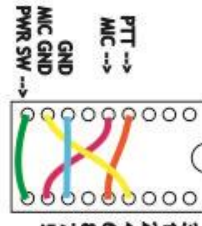
RRC-1258MkII Control		RRC-1258MkII Radio	
AUX/MIC Configuration 	JMP1 DC To Mic	0	AUX/MIC Configuration 
	JMP2 8/9V	0	
	JMP3 RTS-CTS	1	
	JMP5 TTL Pin6	0	

1 = In place, 0 = Not in place, X = doesn't matter

Note! The strapping instructions above are only valid for RRC:s from hardware version 7. Also remember to remove JMP-5 in both the control and radio RRC.

Radio settings (example)

Parameter	Control	Radio
Program mode	15 - FT-857	15 - FT-857
SIP password	hello	hello
SIP contact	192.168.0.228	
Auto connect	No	
Audio quality	2 - Linear 16 bits 8 kHz	2 - Linear 16 bits 8 kHz
Codec out gain	255	255
Codec inp gain	18	0
Codec inp preamp	Yes	
Codec inp HPF Hz	163	163
COM0 baudrate	64000	64000
COM0 data bits	8	8
COM0 stop bits	1	1
COM0 parity	0 - Off	0 - Off

(*) Available only in RRC-1258MkIIs

Connections

The cabling is quite simple and can be done with simple RJ and modular connectors. The 5 wire control cables are the same on control and radio end, but be aware of that the cables must be connected as shown in the schematics.

Drawings of the connection cables can be found below.

Control-RRC:

- The control cable Y9a should be connected between the Control panel and the RRC TTL connector. The Y9a cable is included in the FT-857 package. The cable has a yellow mark in the RRC end, it will not work if you try to use it connected backwards.
- The original microphone can be connected direct to the RRC AUX/MIC connector.
- The speaker is connected direct to the RRC SP-jack with a 3.5 mm stereo plug or to the FT-857 front panel speaker jack.

Radio-RRC:

- The control cable Y9a should be connected between the Radio-RRC and the Radio. The Y9a cable is included in the FT-857 package. The cable has a yellow mark in the RRC end, it will not work if you try to use it connected backwards.
- Between the RRC AUX/MIC connector and the radios microphone jack you can connect the standard screened patch cable (CAT5 or CAT6) included in the FT-857 package.

Power supply

Control-RRC:

The Control-RRC is supplied with a common 13,8 V (10-18V) power supply. The display and speaker amplifier needs a lot of power so you need 1A.

Radio-RRC:

The Radio-RRC should be supplied from the same power supply as the radio to avoid humming. Please put a small fuse on the cable if you connect it to a 30 Amp PS.

DET NR.	CNT	NAME		DIMENSION		NOTE	
CONSTR.	DRAWN	CHECKED	STAND.	SCALE	REPLACE	REPLACED BY	
MS			OK	1, 2			
microbit		YAESU FT-857 Cable Contr. panel -> RRC-1258MkII				DATE	120124
						DRAWING NR.	1258 Cable Y9 1(1)

Ctrl Panel FT-857

6-pol modular

- 1 ○
- 2 ○
- 3 ○
- 4 ○
- 5 ○
- 6 ○

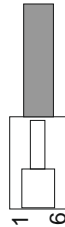

RRC-1258MkII TTL

6-pol modular

- 1 PWR SW
- 2 8V
- 3 GND
- 4 RXD
- 5 TXD
- 6 SP

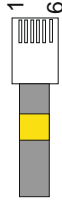

Y9a

SPEAKER
3.5 mm stereo plug

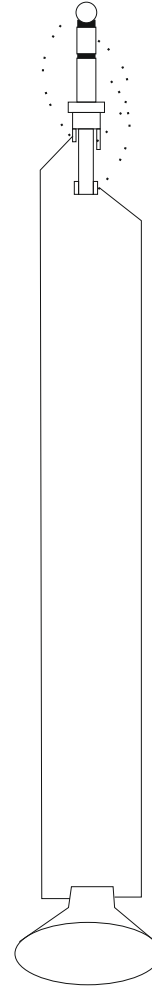

DET NR.	CNT	NAME	DIMENSION	NOTE
CONSTR.	DRAWN	CHECKED/STAND.	SCALE	REPLACE
MS		OK	1:2	
		YAESU FT-857 cable RRC-1258MkII -> Radio	DRAWING NR 1258 Cable Y9 1(1)	DATE 120124

**RRC-1258MkII
AUX/MIC**

MIC FT-857

8-pol RJ 45 Con

Try Standard shielded CAT 5

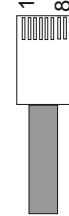
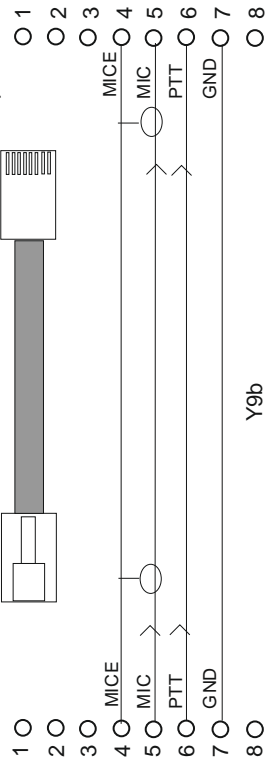
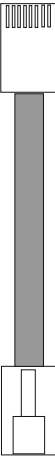

RRC-1258MkII TTL

6-pol modular

CTRL FT-857

6-pol modular

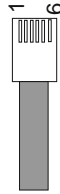
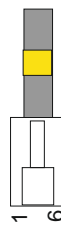
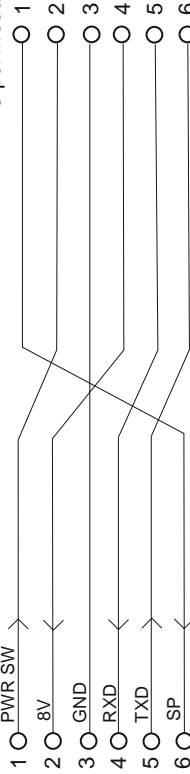

YAESU FTM-350

General

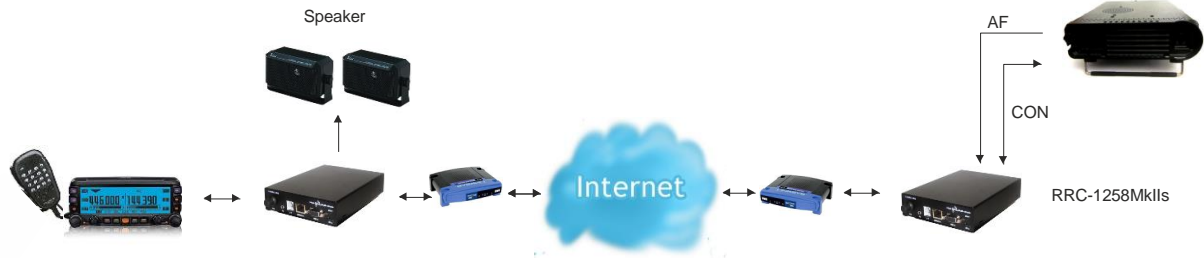

The Remoterig system supports the Yaesu FTM-350. The technical solution is the same as for all the other rigs with detachable control panel. You can remote control the radio over Internet from the control panel without any PC. We simply replace the cable between the control panel and the radio with two RRC-1258 units, one at the control panel and one at the radio. When you push the PWR-ON button an audio and data connection is established between the units and you control the radio as you do normally with the control panel directly attached to the radio.

Hardware configuration

The FTM-350 is supported by the Remoterig RRC-1258MkIIs from version 5 as it needs dual audio support.

FTM-350

RRC-1258MkII Control		RRC-1258MkII Radio	
	JMP1 DC To Mic	0	
	JMP2 8/9V	0	
	JMP3 RTS-CTS	1	
	JMP5 TTL Pin6	1	

1 = in place, 0 = Not in place, X = doesn't matter

The small built in speakers in the control panel can not be used, separate speakers have to be connected directly to the Control-RRC speaker jack.

As the mic levels between the control panel and the radio are very different compared to other (much higher) a small modification must be done to the Radio-RRC PCB. A 10K resistor has to be mounted in parallel with R71. This is done quite easily, see picture below.

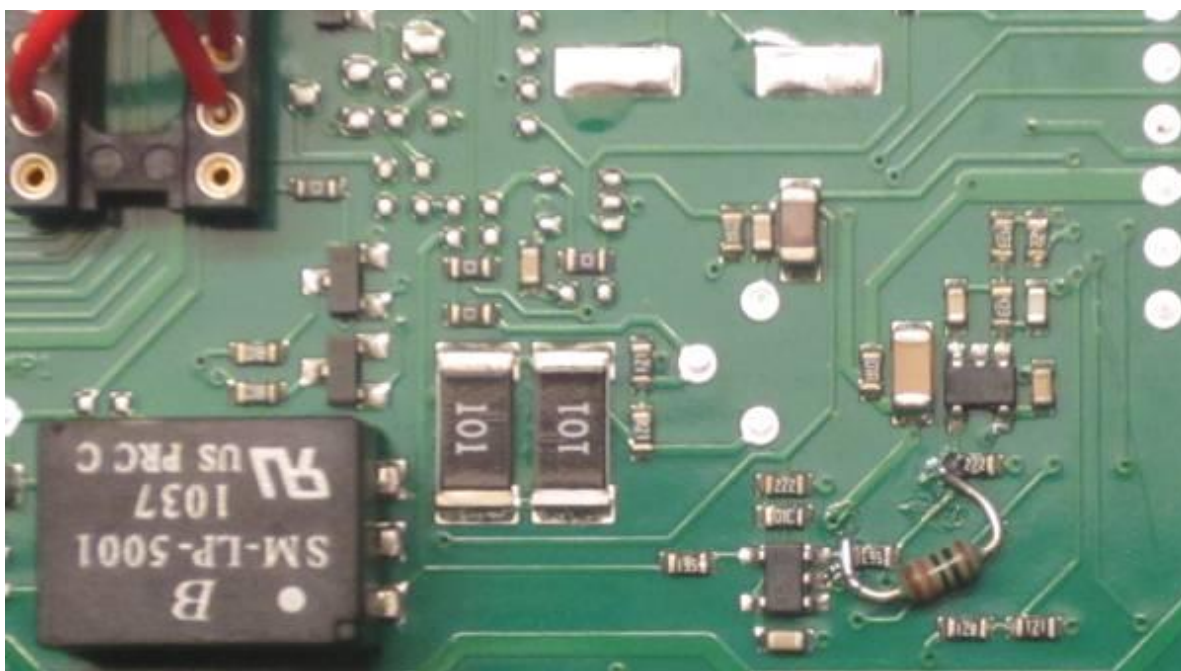

Radio settings (example)

Parameter	Control	Radio
Program mode	17 - FTM-350	17 - FTM-350
SIP password	hello	hello
SIP contact	192.168.0.228	
Auto connect	No	
Audio quality	2 - Linear 16 bits 8 kHz	2 - Linear 16 bits 8 kHz
Audio dual-rx		Yes
Codec out gain	255	255
Codec inp gain	20	0
Codec inp preamp	No	
Codec inp HPF Hz	163	163
COM0 baudrate	48000	48000
COM0 data bits	8	8
COM0 stop bits	1	1
COM0 parity	0 - Off	0 - Off

Connections

The cabling is quite simple and can be done with standard patch cables. Drawings of the connection cables can be found below.

Control-RRC:

- The control cable Y13a a standard RJ-45 patch cable should be connected between the Control panel and the AUX/MIC connector.
- The original microphone should be connected direct to the radio front panel as usual.
- A pair of speakers are connected direct to the RRC SP-jack with a 3.5 mm stereo plug. A set of amplified PC speakers will work very well also.

Radio-RRC:

- The control cable Y14a a standard RJ-45 patch cable should be connected between the Radio-RRC AUX/MIC jack and the Radio.
- The speaker cable (Y14bc) eg. a standard cable with 3.5 mm mono connectors in both ends should be connected between the radio and the Radio-RRC speaker jack.

Power supply

Control-RRC:

The Control-RRC is supplied with a common 13,8 V (10-18V) power supply. The display and speaker amplifier needs a lot of power so you need 1A.

Radio-RRC:

The Radio-RRC should be supplied from the same power supply as the radio to avoid humming. Please put a small fuse on the cable if you connect it to a 30 Amp PS.

DET NR.	CNT	NAME	DIMENSION	NOTE
CONSTR.	DRAWN	CHECKED/STAND.	SCALE	REPLACE
MS		OK	1:2	REPLACED BY
		YAESU FTM-350 Cables	1258 Cable Y13 1(1)	DATE
		Front -> RRC-1258MkII		121106
DRAWING NR 1258 Cable Y13 1(1)				

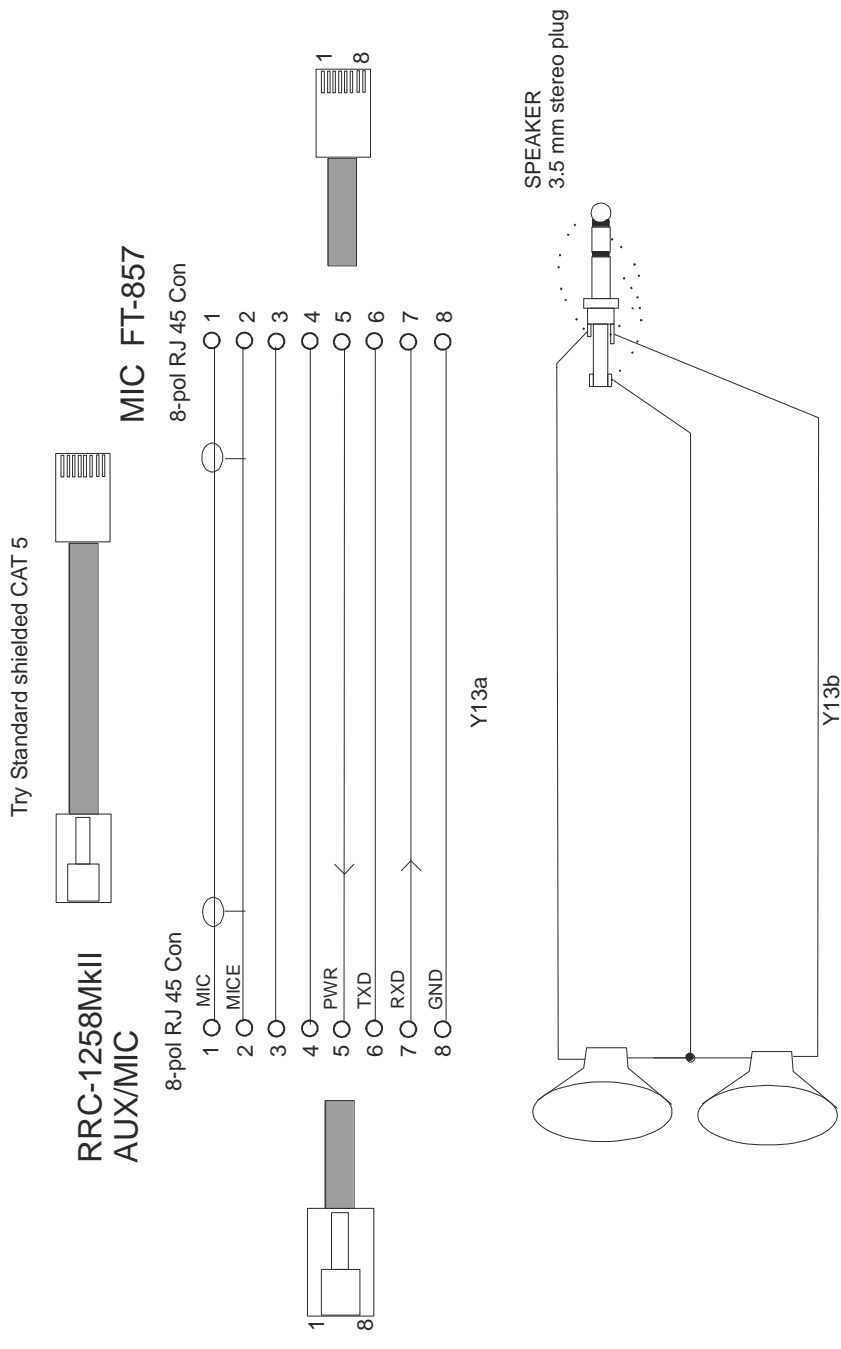

DET NR.	CNT	NAME	DIMENSION	NOTE
CONSTR.	DRAWN	CHECKED/STAND.	SCALE	REPLACE
MS		OK	1:2	REPLACED BY
			YAESU FTM-350 Cables RRC-1258MKII -> Radio	DATE
				121105
DRAWING NR				1258 Cable Y14 1(1)

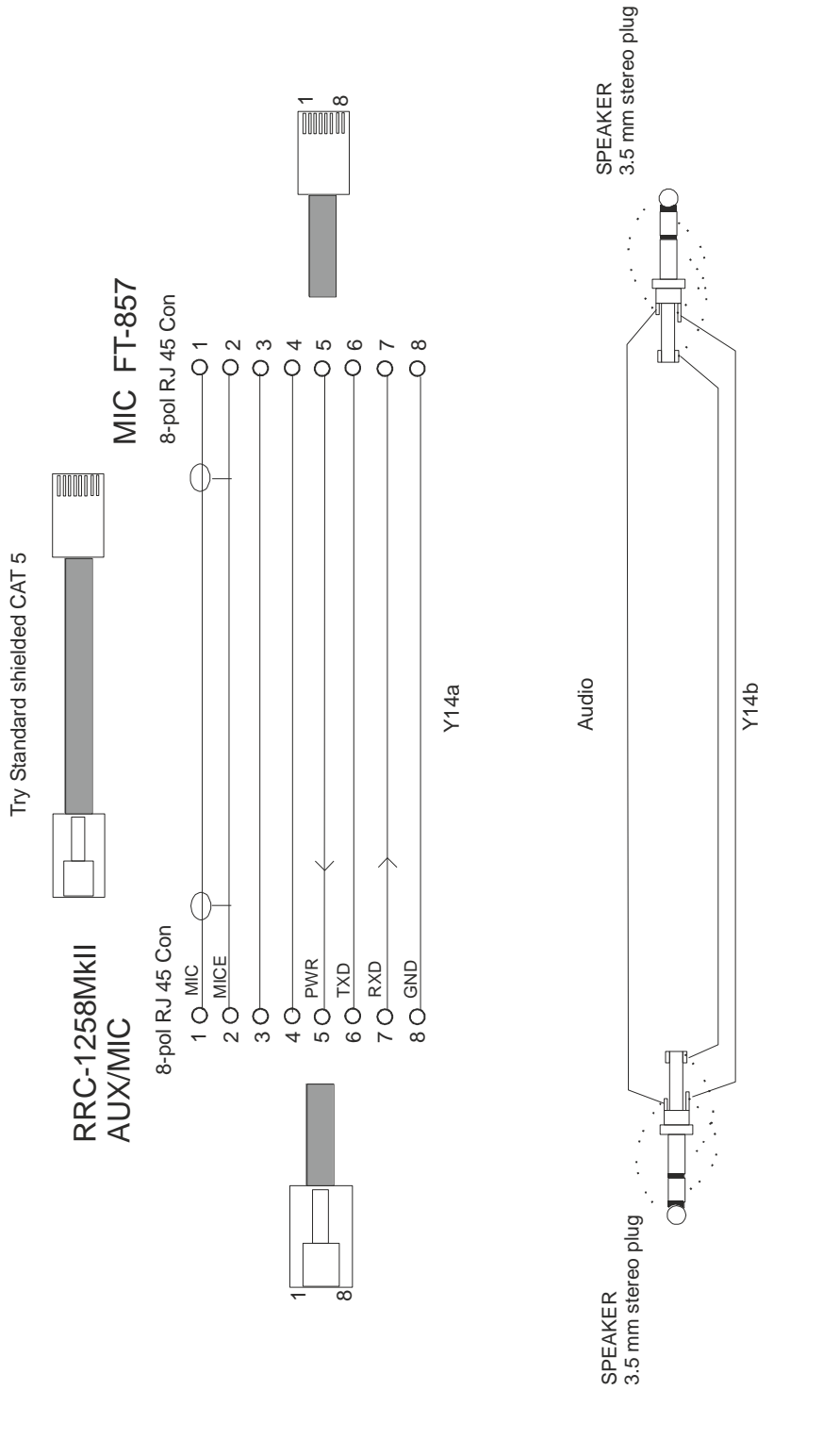

YAESU FT-7800/7900/8800/8900

General

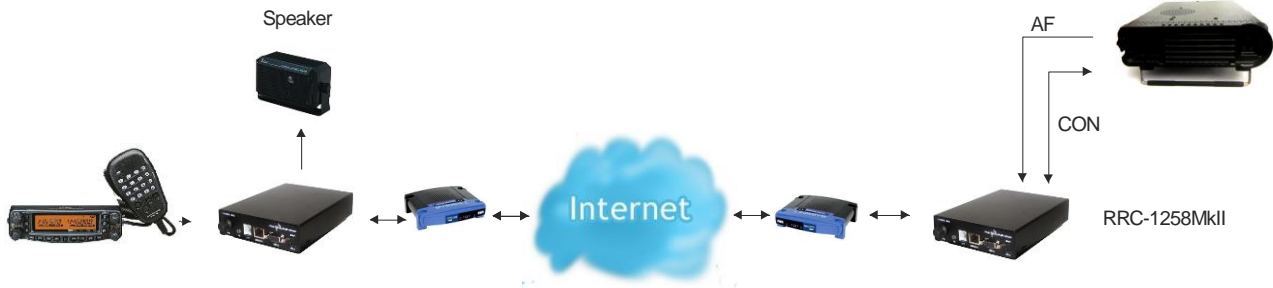

The Remoterig system supports the Yaesu FT-7800/7900/8800/8900. The technical solution is the same as for all the other rigs with detachable control panel. You can remote control the radio over Internet from the control panel without any PC. We simply replace the cable between the control panel and the radio with two RRC-1258 units, one at the control panel and one at the radio. When you push the PWR-ON button an audio and data connection is established between the units and you control the radio as you do normally with the control panel directly attached to the radio.

Hardware configuration

The FT-7800/7900/8800/8900 is fully supported by the Remoterig RRC-1258MkIIs from version 3.

Note!

Be aware of that the FT-8800 has a bug which can cause it to enter a kind of "locked" mode when it loses power, you then need to connect the front panel direct to the radio again to recover. So we recommend using the FT-8900 or FT-7800/7900 to avoid this situation.

FT-7800/8800/8900

RRC-1258MkII Control		RRC-1258MkII Radio	
<p>AUX/MIC</p>	JMP1 DC To Mic	1	<p>AUX/MIC</p>
	JMP2 8/9V	1	
	JMP3 RTS-CTS	1	
	JMP5 TTL Pin6	1	

1 = in place, 0 = Not in place, X = doesn't matter

Radio settings (example)

Parameter	Control	Radio
Program mode	15 - FT-857/8800/8900	15 - FT-857/8800/8900
SIP password	hello	hello
SIP contact	192.168.0.228	
Auto connect	No	
Audio quality	2 - Linear 16 bits 8 kHz	2 - Linear 16 bits 8 kHz
Audio dual-rx (*)		No
Codec out gain	255	255
Codec inp gain	18	0
Codec inp preamp	Yes	
Codec inp HPF Hz	163	163
COM0 baudrate	19200	19200
COM0 data bits	8	8
COM0 stop bits	1	1
COM0 parity	0 - Off	0 - Off

(*) Available only in RRC-1258MkIIs

Connections

The cabling is quite simple and can be done with simple RJ and modular connectors. The 6 wire control cables are the same on control and radio end. Drawings of the connection cables can be found below.

Control-RRC:

- The control cable Y10a should be connected between the Control panel and the AUX/MIC connector.
- The original microphone should be connected direct to the radio front panel as usual.
- A speaker is connected direct to the RRC SP-jack with a 3.5 mm stereo plug.

Radio-RRC:

- The control cable Y10a should be connected between the Radio-RRC AUX/MIC jack and the Radio.
- The speaker cable (Y10c) eg. a standard cable with 3.5 mm mono connectors in both ends should be connected between the radio and the Radio-RRC speaker jack. If a cable with stereo plugs are used the ring must be connected to GND in the Radio end otherwise the radio will not sense that a speaker is connected.

Power supply

Control-RRC:

The Control-RRC is supplied with a common 13,8 V (10-18V) power supply. The display and speaker amplifier needs a lot of power so you need 1A.

Radio-RRC:

The Radio-RRC should be supplied from the same power supply as the radio to avoid humming. Please put a small fuse on the cable if you connect it to a 30 Amp PS.

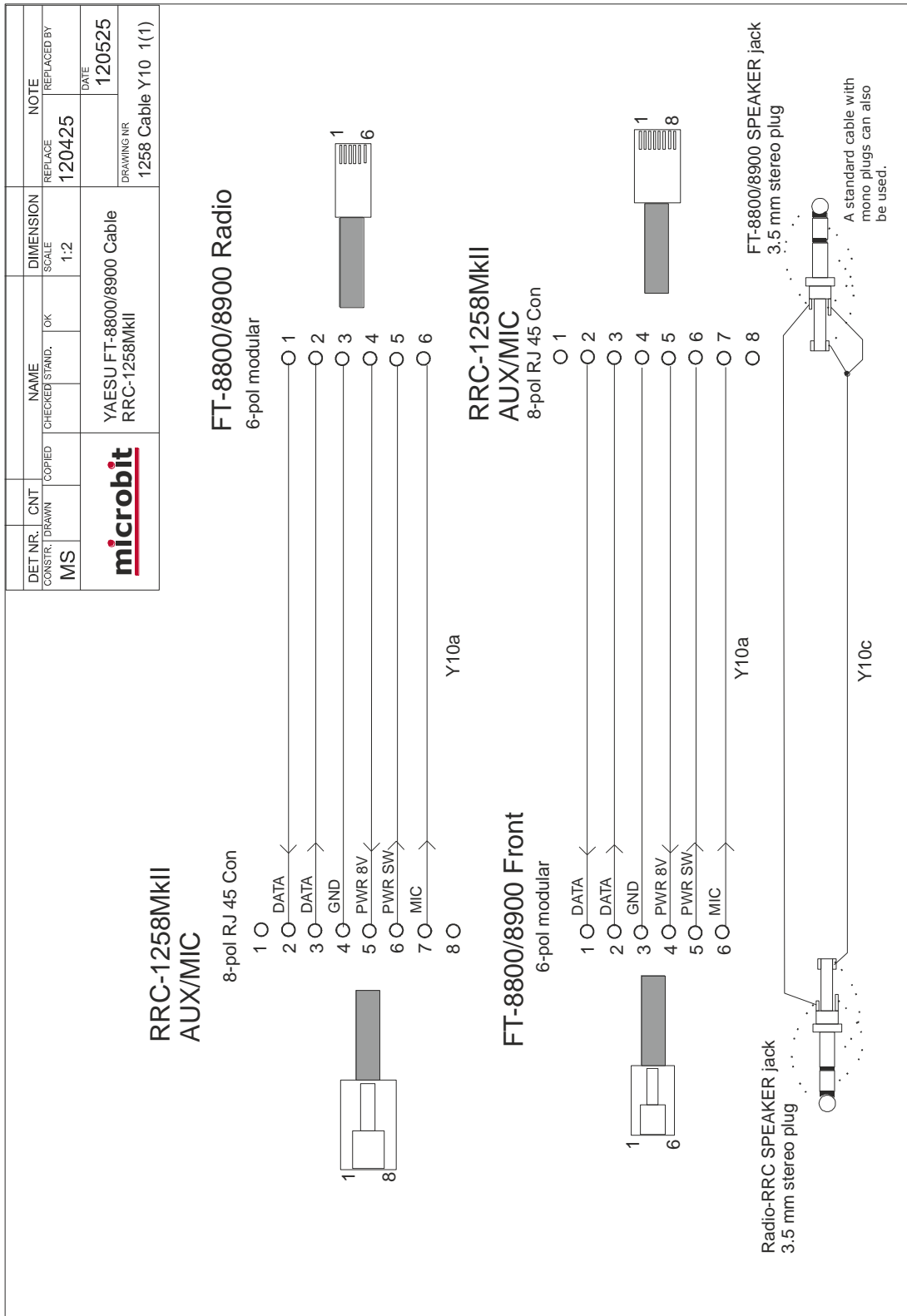

Note: The schematic is valid for all three models FT-7800/8800/8900.

YAESU FT-897, FT-1000 etc.

General

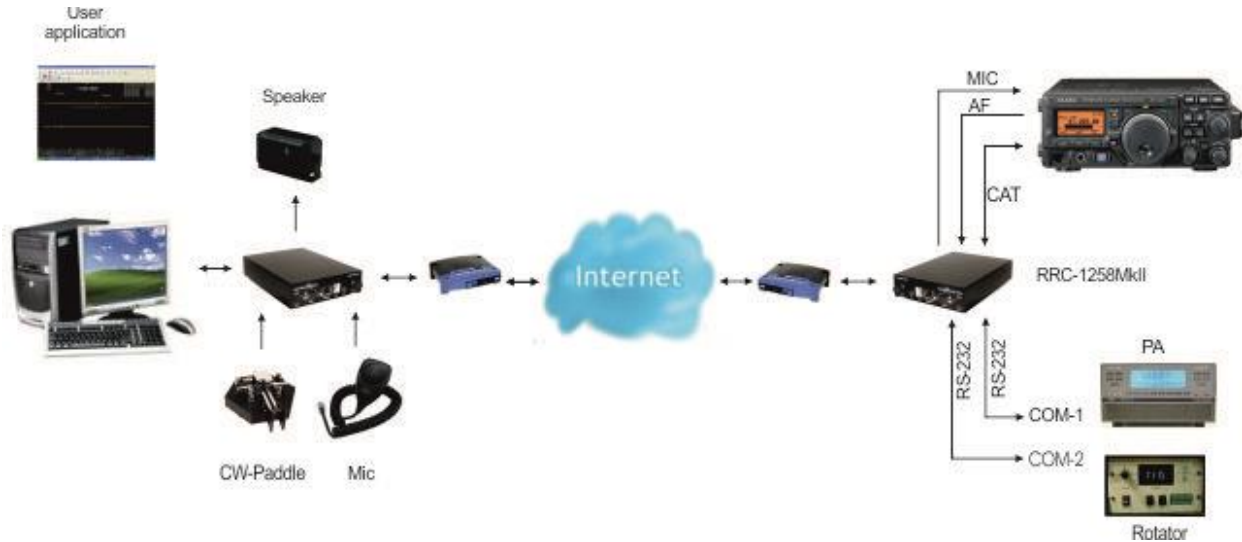

RRC-1258MkII supports the YAESU CAT protocol used by almost every YAESU radio. Then you have to use a PC-software e.g. HamRadioDeLuxe or similar rig control software at the control site. All audio and data communication goes true the RRC:s and you don't need a PC at the remote site.

Hardware configuration

Yaesu

RRC-1258MkII Control		RRC-1258MkII Radio	
AUX/MIC Configuration 	JMP1 DC To Mic	0	AUX/MIC Configuration
	JMP2 8/9V	1	
	JMP3 RTS-CTS	1	
	JMP5 TTL Pin6	1	

1 = In place, 0 = Not in place, X = doesn't matter

Radio settings (example)

Parameter	Control	Radio
Program mode	3 – FT-8x7, FT-1000x	3 – FT-8x7, FT-1000x
SIP password	hello	hello
SIP contact	192.168.0.228	
Auto connect	No	
Audio quality	2 – Linear 16 bits 8 kHz	2 – Linear 16 bits 8 kHz
Audio dual-rx *		No/Yes (ev. for FT-1000xx)
Codec out gain	255	255
Codec inp gain	18	0
Codec inp preamp	Yes	
Codec inp HPF Hz	163	163
COM0 baudrate	9600	9600
COM0 data bits	8	8
COM0 stop bits	1**	1**
COM0 parity	0 - Off	0 - Off

(*) Available only in RRC-1258MkIIs, remember that the bandwidth demand is doubled.

(**) check with the radio users manual, some model need 2 stopbits.

Connections

Drawings of the connection cables can be found under appendix B.

Control-RRC:

- Connect the Remoterig Y5c cable or a standard RS-232 cable between the PC and the RRC COM2.
- The microphone can be connected direct to the RRC AUX/MIC connector if you have a microphone with RJ-45 connector. If you have a microphone with a circular connector you can use the Remoterig Y5a adapter cable or the ADMY-817, from Yaesu or make one by yourself.
- The speaker is connected direct to the RRC SP-jack with a 3.5 mm stereo plug.

Radio-RRC:

- From the RRC COM2 connector to the radios CAT connector (D-sub RS-232) you can use the Remoterig Y6c cable or make one by yourself (drawing for Y6c is provided). The smaller radios in the FT-8x7 series do not have a D-sub or RS-232 port; they only have a TTL-port accessible via a mini-DIN jack. You can either buy an adapter cable, D-sub to mini-DIN, with a level converter called CT-62 from Yaesu or you can make a cable by yourself and connect it to the RRC TTL connector.
- Between the RRC AUX/MIC connector and the radios microphone jack you can connect a standard patch cable if the radio have a RJ-45 jack. If the radio have a circular microphone jack you can use the Remoterig Y6a cable or make it by yourself (drawings are provided). Make the cable as short as possible to prevent it from picking up HF.

- The speaker signal from the radios external speaker jack to the RRC SP jack is connected via a standard "off- the-shelf" cable with 3.5 mm stereo plugs in both ends.



Y5a,Y6a



Y5c,Y6c

DET NR. CONSTR. DRAWN	CNT MS	NAME CHECKED STAND. OK	DIMENSION SCALE	NOTE REPLACE
MS		Generic YAESU Cable RRC-1258MkII to Yaesu (FT-2000)	1:2	091124
microbit				DATE 110306
				DRAWING NR 1258 Cable Y5 1(1)

RRC-1258MkII

8-pol RJ 45 Con

Mic Inp
8-pol Circular

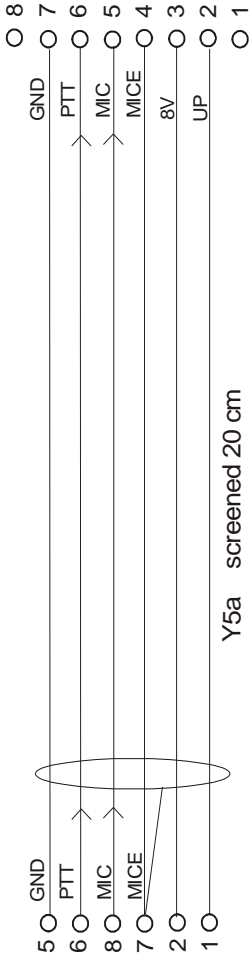
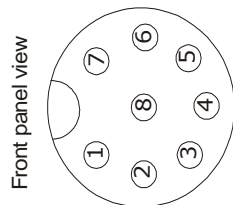

Y5a screened 20 cm

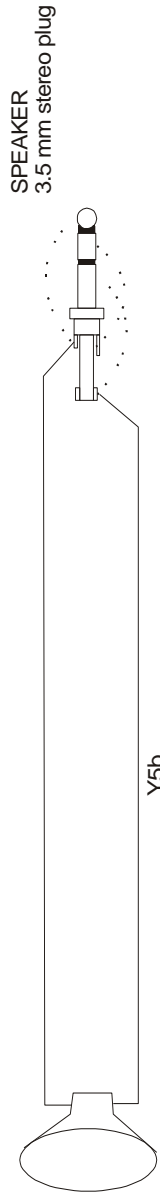

SPEAKER
3.5 mm stereo plug

PC



Y5c

DSUB- 9pol
Female

DSUB- 9pol
Male

RRC-1258MkII

COM2

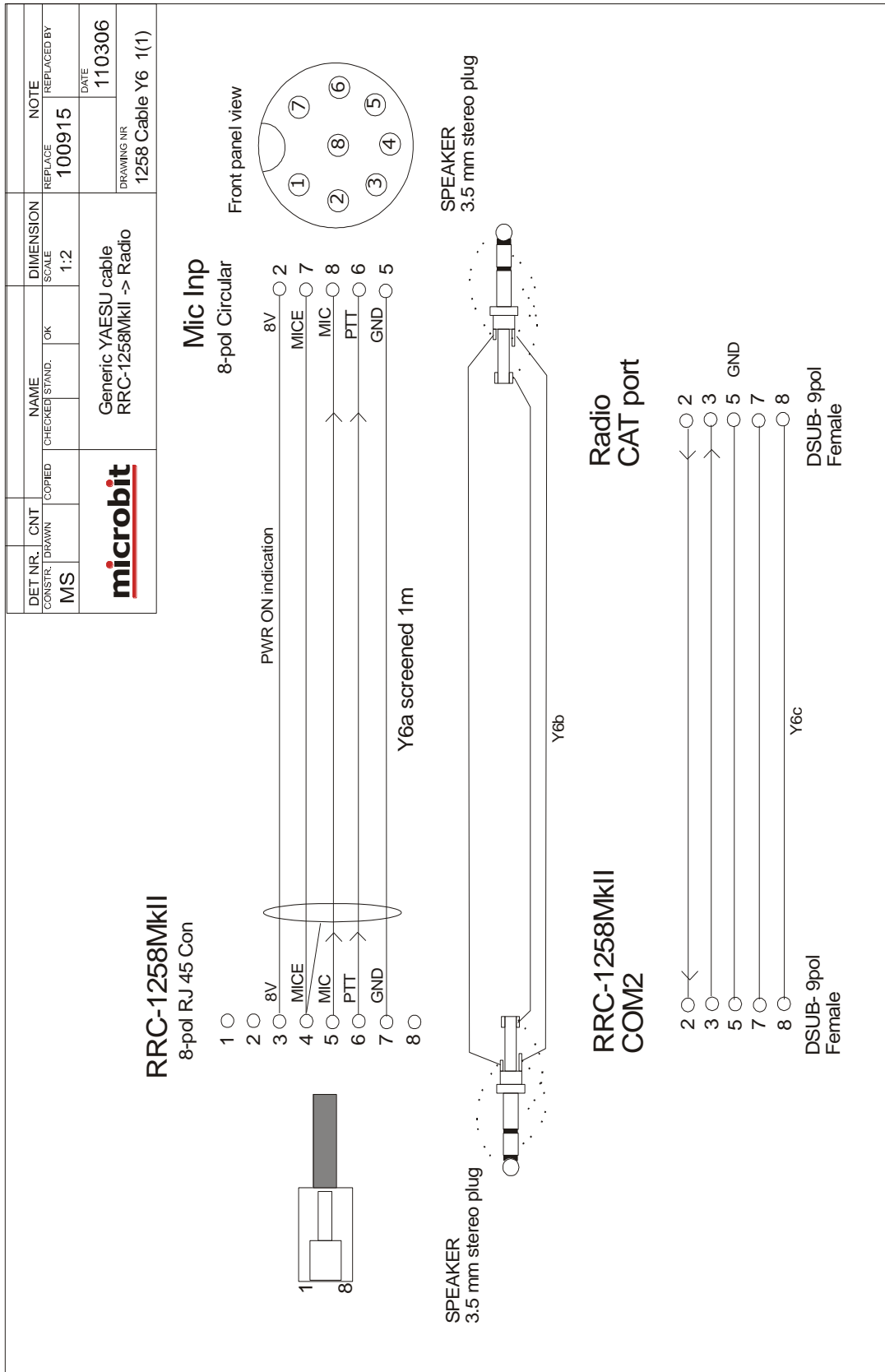

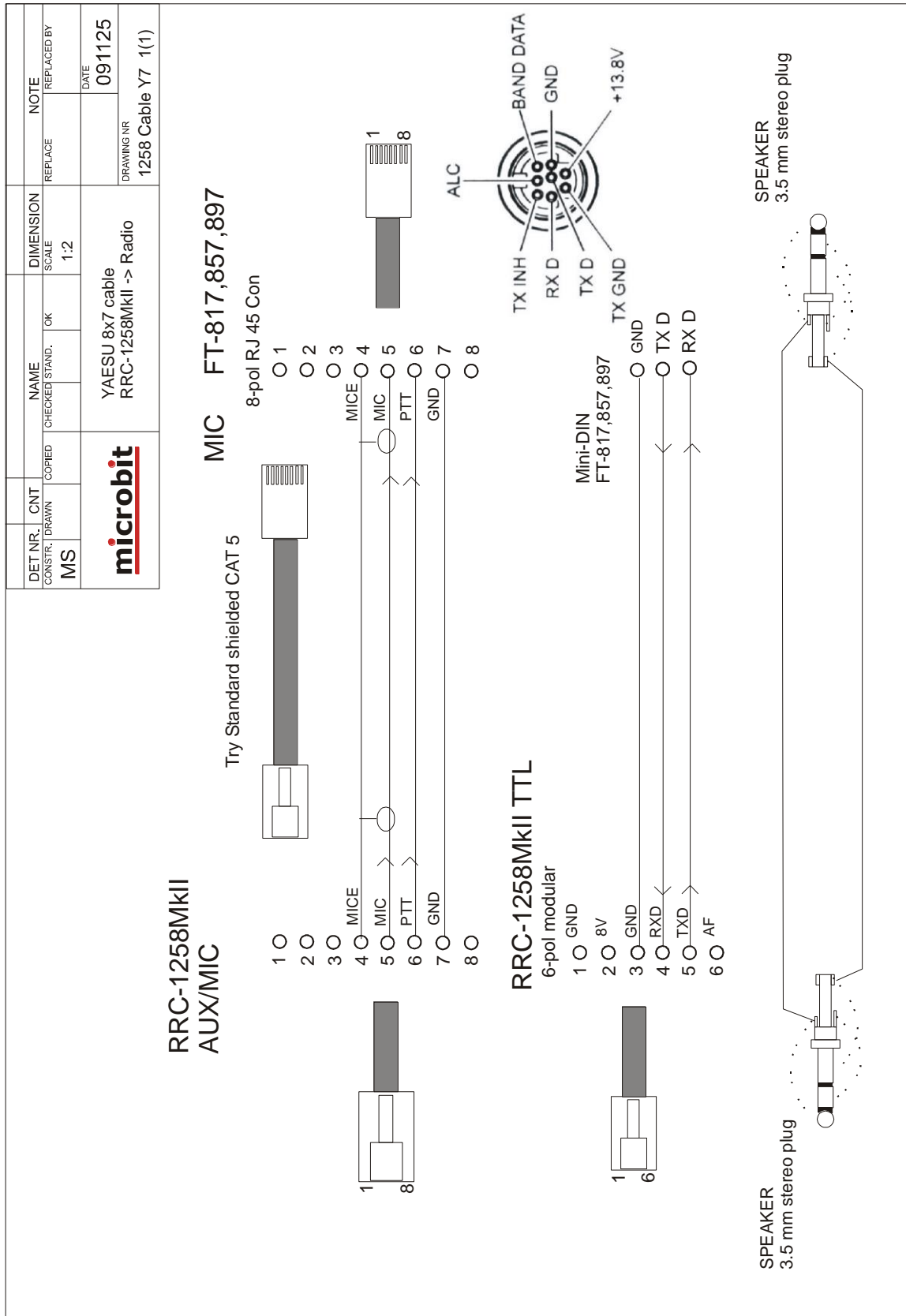

YAESU in General (FT-2000)

General

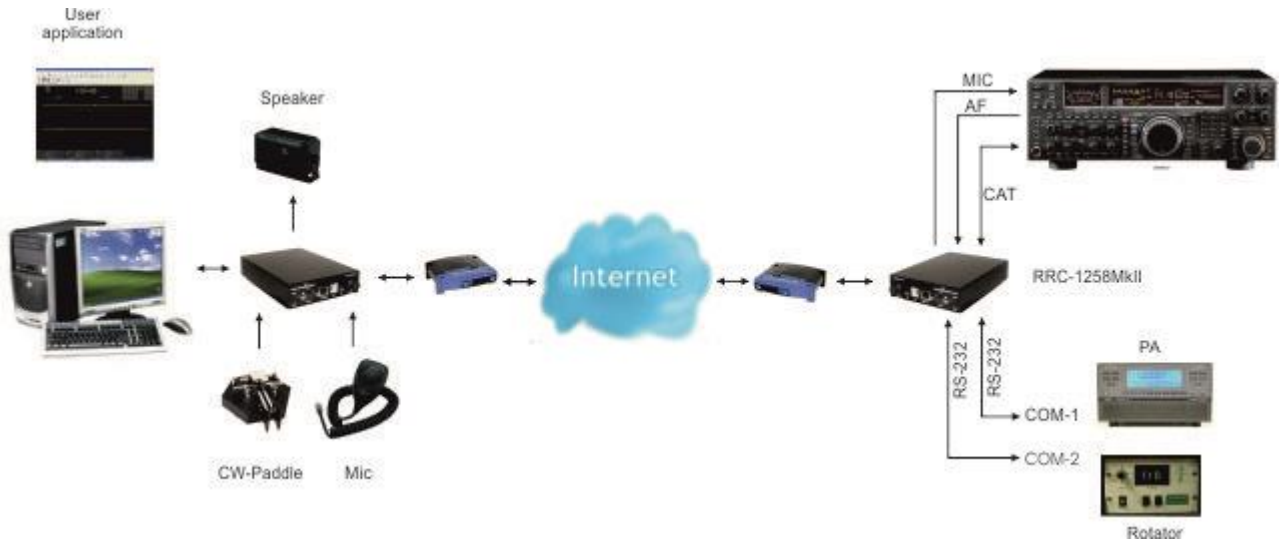

RRC-1258MkII supports the YAESU CAT protocol used by almost every YAESU radio. Then you have to use a PC-software e.g. HamRadioDeLuxe or similar rig control software at the control site. All audio and data communication goes true the RRC:s and you don't need a PC at the remote site.

Hardware configuration

Yaesu

RRC-1258MkII Control		RRC-1258MkII Radio	
AUX/MIC Configuration AUX/MIC	JMP1 DC To Mic 0	AUX/MIC Configuration AUX/MIC	
	JMP2 8/9V 1		
	JMP3 RTS-CTS 1		JMP3 RTS-CTS 1
	JMP5 TTL Pin6 1		JMP5 TTL Pin6 1

1 = In place, 0 = Not in place, X = doesn't matter

Radio settings (example)

Parameter	Control	Radio
Program mode	4 – Yaesu, Kenwood, Elecraft	4 – Yaesu, Kenwood, Elecraft
SIP password	hello	hello
SIP contact	192.168.0.228	
Auto connect	No	
Audio quality	2 – Linear 16 bits 8 kHz	2 – Linear 16 bits 8 kHz
Audio Dual-RX (*)	-	Yes
Codec out gain	255	255
Codec inp gain	18	0
Codec inp preamp	Yes	
Codec inp HPF Hz	163	163
COM0 baudrate	9600	9600
COM0 data bits	8	8
COM0 stop bits	1	1
COM0 parity	0 – Off	0 – Off

(*) Available only in RRC-1258MkIIs, remember that the bandwidth demand is doubled.

Note! Set the CAT speed in radios to 38400 baud, and set RTS to No

Connections

Drawings of the connection cables can be found below.

Control-RRC:

- Connect the Remoterig Y5c or a standard RS-232 cable between the PC and the RRC COM2.
- The microphone can be connected direct to the RRC AUX/MIC connector if you have a microphone with RJ-45 connector. If you have a microphone with a circular connector you can use the Remotrig Y5a cable, the ADMY-817, from Yaesu or make one by yourself.
- The speaker is connected direct to the RRC SP-jack with a 3.5 mm stereo plug.

Radio-RRC:

- From the RRCCOM2 connector to the radios CAT connector (D-sub RS-232) you can use the Remoterig Y6c cable or make a cable by yourself (drawings are provided). The smaller radios in the FT-8x7 series do not have a D-sub or RS-232 port; they only have a TTL-port accessible via a mini-DIN jack. You can either buy an adapter cable, D-sub to mini-DIN, with a level converter called CT-62 from Yaesu or you can make a cable by yourself and connect it to the RRC TTL connector.
- Between the RRC AUX/MIC connector and the radios microphone jack you can connect a standard patch cable if the radio have a RJ-45 jack. If the radio have a circular microphone jack you can use the Remoterig Y6a cable or make an adapter cable by yourself (drawings are provided). If you make the cable by yourself, just cut a standard FTP (screened) patch cable and solder an 8-pin circular connector on it. Make the cable as short as possible to prevent it from picking up HF.
- The speaker signal from the radios external speaker jack to the RRC SP jack is connected via a standard "off- the-shelf" cable with 3.5 mm stereo plugs in both ends.



Y5a,Y6a



Y5c,Y6c

DET NR.	CNT	NAME	DIMENSION	NOTE
CONSTR.	DRAWN	CHECKED	SCALE	REPLACE
MS		OK	1:2	091124
microbit		Generic YAESU Cable RRC-1258MkII to Yaesu (FT-2000)		DATE 110306
				DRAWING NR 1258 Cable Y5 1(1)

RRC-1258MkII

8-pol RJ 45 Con

Mic Inp
8-pol Circular

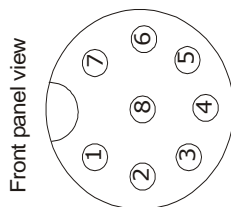

- 5 ○ GND ○ 8
- 6 ○ PTT ○ 7
- 8 ○ MIC ○ 6
- 7 ○ MICE ○ 5
- 2 ○ 8V ○ 4
- 1 ○ UP ○ 3
- 1

Y5a screened 20 cm

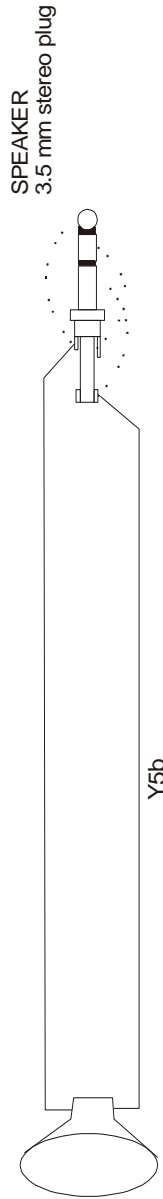
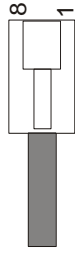

SPEAKER
3.5 mm stereo plug

Y5b

PC

- 2 ○ ← 2
- 3 ○ → 3
- 5 ○ 5
- 7 ○ 7
- 8 ○ 8

DSUB- 9pol
Female

Y5c

DSUB- 9pol
Male

RRC-1258MkII

COM2

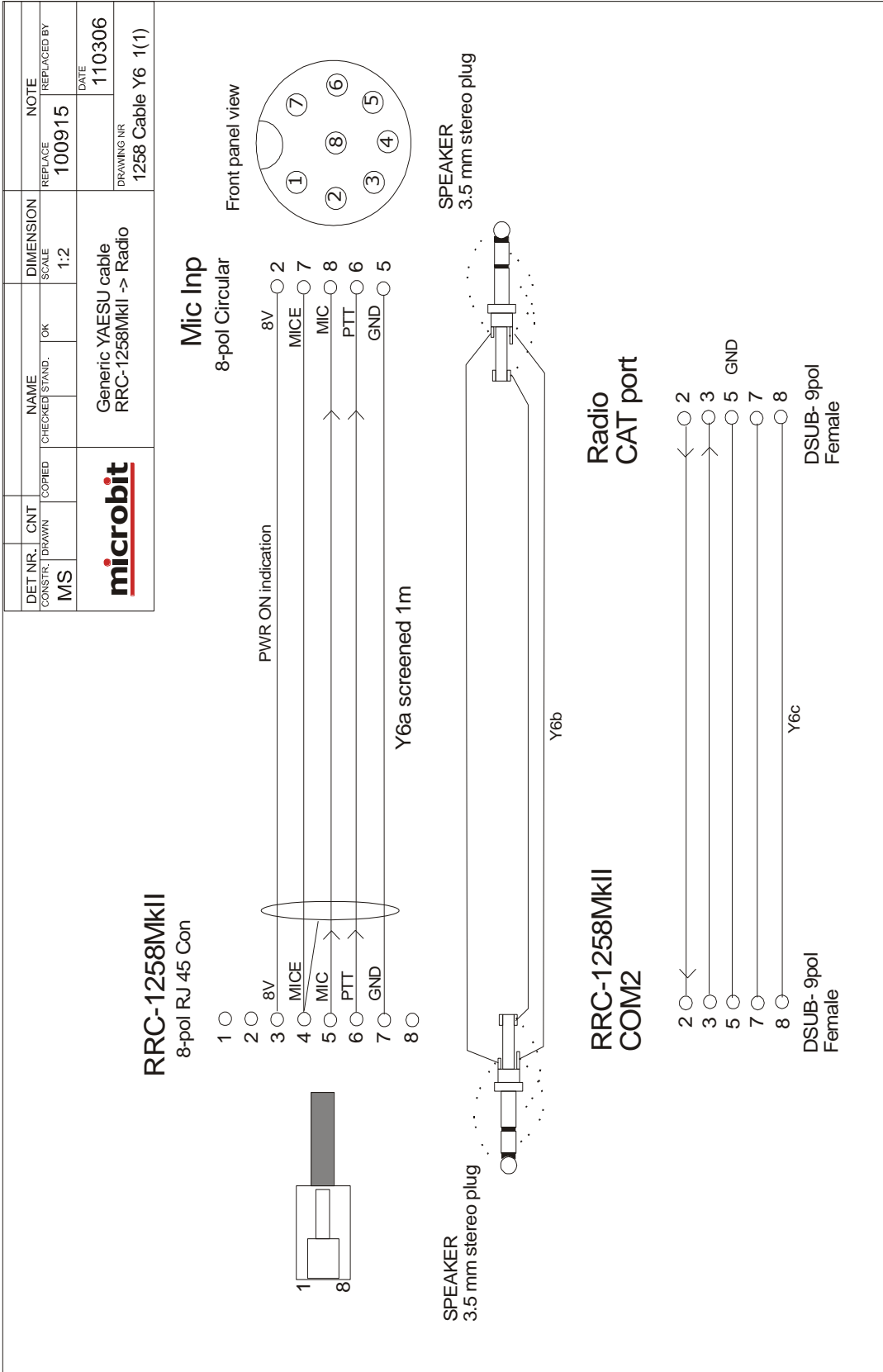

KENWOOD in General

General

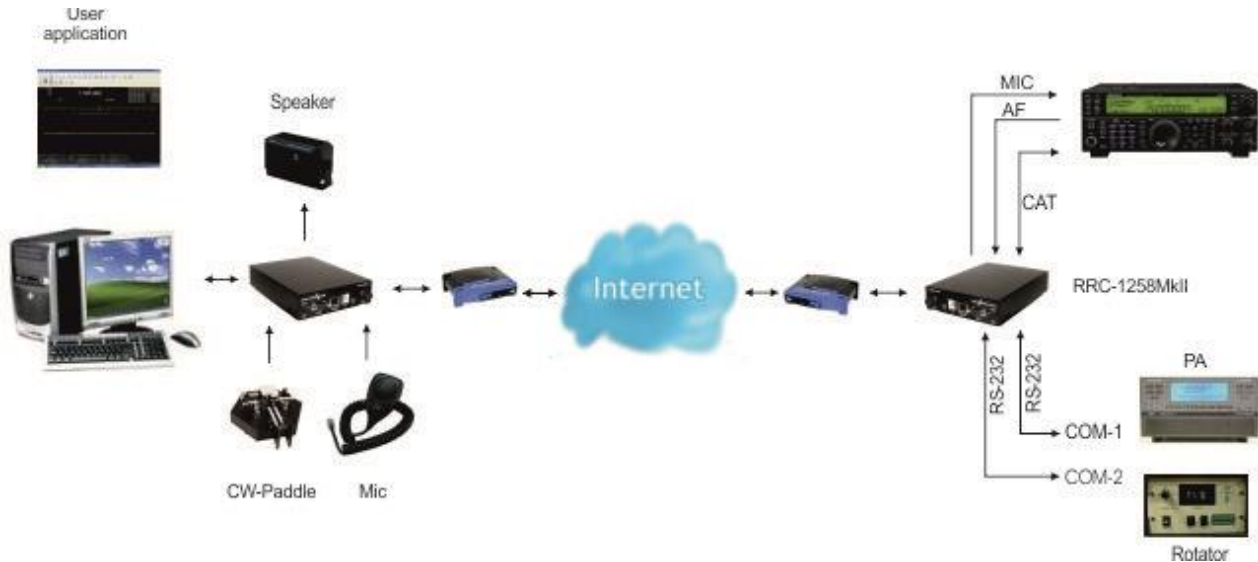

RRC-1258MkII supports the Kenwood protocol used by almost every Kenwood radio. Then you have to use a PC-software e.g. HamRadioDeLuxe or similar rig control software at the control site. All audio and data communication goes true the RRC:s and you don't need a PC at the remote site.

Hardware configuration

Kenwood

RRC-1258MkII Control		RRC-1258MkII Radio	
AUX/MIC Configuration AUX/MIC	JMP1 DC To Mic 0	 AUX/MIC	
	JMP2 8/9V 0		
	JMP3 RTS-CTS 1		JMP3 RTS-CTS 1
	JMP5 TTL Pin6 1		JMP5 TTL Pin6 1

1 = In place, 0 = Not in place, X = doesn't matter

SIP-Connect/disconnect via MIC UP button:

Kenwood SIP-Connect/Disconnect via MIC UP button

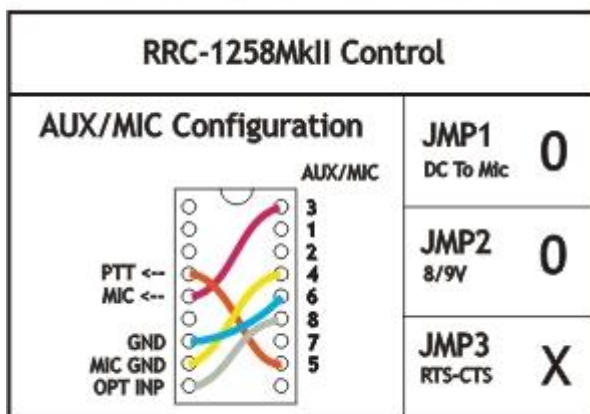

1 = In place, 0 = Not in place, X = doesn't matter

Radio settings (example)

Parameter	Control	Radio
Program mode	4 – Yaesu, Kenwood, Elecraft	4 – Yaesu, Kenwood, Elecraft
SIP password	hello	hello
SIP contact	192.168.0.228	
Auto connect	No	
Audio quality	2 – Linear 16 bits 8 kHz	2 – Linear 16 bits 8 kHz
Audio dual-rx (*)		No
Codec out gain	255	255
Codec inp gain	13	0
Codec inp preamp	Yes	
Codec inp HPF Hz	163	163
COM0 baudrate	9600	9600
COM0 data bits	8	8
COM0 stop bits	1	1
COM0 parity	0 - Off	0 - Off

*) Available only in RRC-1258MkIIs.

Connections

Drawings of the connection cables can be found under appendix B.

Control-RRC:

- Connect the Remoterig K14c Cable or a standard RS-232 cable between the PC and the RRC COM2.
- The microphone can be connected direct to the RRC AUX/MIC connector if you have a microphone with RJ-45 connector. If you have a microphone with a circular connector you can use the Remoterig K13a cable, the MJ-88, from Kenwood or make one by yourself (drawings are provided).
- The speaker is connected direct to the RRC SP-jack with a 3.5 mm stereo plug.

Radio-RRC:

- From the RRC COM2 connector to the radios CAT connector (D-sub RS-232) you use the Remoterig K15c cable or make one by yourself (drawings are provided).
- Between the RRC AUX/MIC connector and the radios microphone jack you can connect a standard patch cable if the radio have a RJ-45 jack. If the radio have a circular microphone jack you can use the Remoterig K12a cable or make one by yourself (drawings are provided). Make the cable as short as possible to prevent it from picking up HF.
- The speaker signal from the radios external speaker jack to the RRC SP jack is connected via a standard "off- the-shelf" cable with 3.5 mm stereo plugs in both ends.



K14a,K15a



K14c,K15c

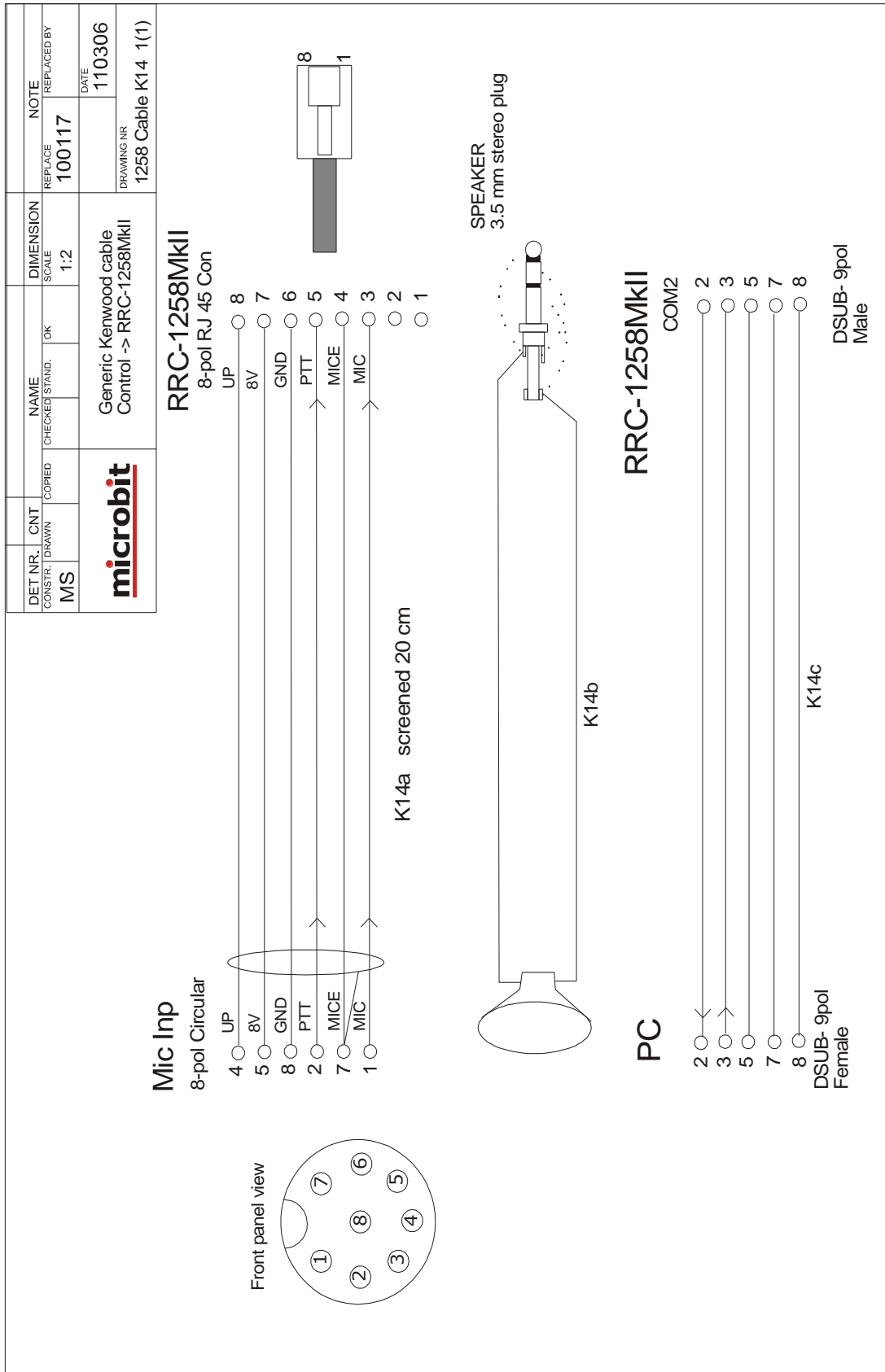

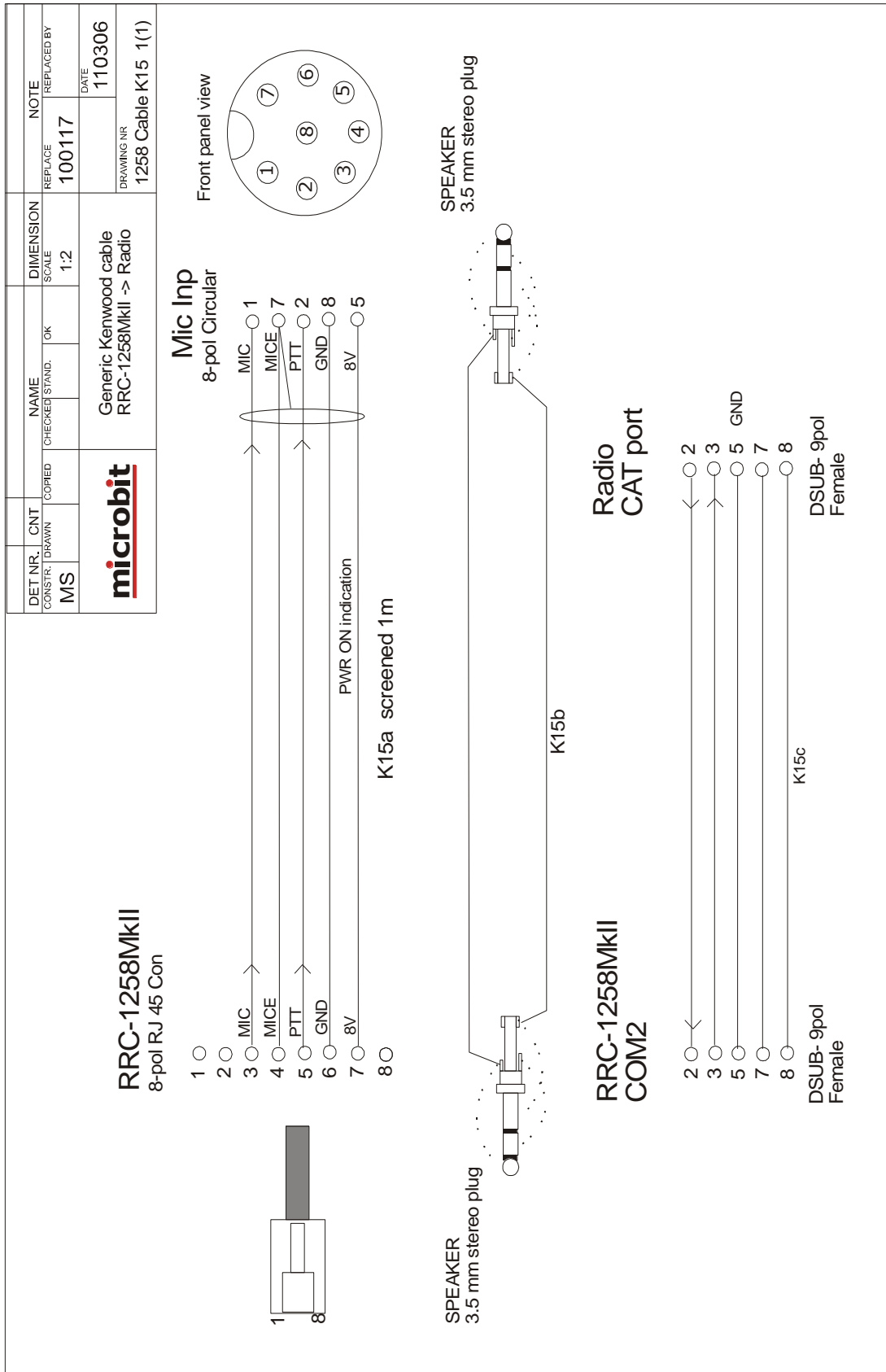

KENWOOD TS-480

General



The idea of remote controlling TS-480 is simple; it's just to extend the cord between the radio and the control panel using Internet. When you press the power button on the panel the radio comes to life at the remote side and sound and panel info flows across the Internet between the pair of RRC-1258MkII:s. The look and feel of the panel is the same as if the panel was directly connected to the radio.

Hardware configuration

To make things a little bit more complicated Kenwood have changed the layout of the Mic connector during production and there are two different configurations. Newer radios are using config type 1 and very old config type 2. Kenwood has changed their serial numbering system so it's not possible to say when the brake was. But use config 1 to start, if you suffer from RFI and suspect your radio is very old you can try config 2.

Configuration type 1:

Kenwood TS-480 conf-1

RRC-1258MkII Control		RRC-1258MkII Radio	
	JMP1 DC To Mic	0	
	JMP2 8/9V	1	
	JMP3 RTS-CTS	1	
	JMP5 TTL Pin6	1	

1 = In place, 0 = Not in place, X = doesn't matter

Configuration type 2:
Kenwood TS-480

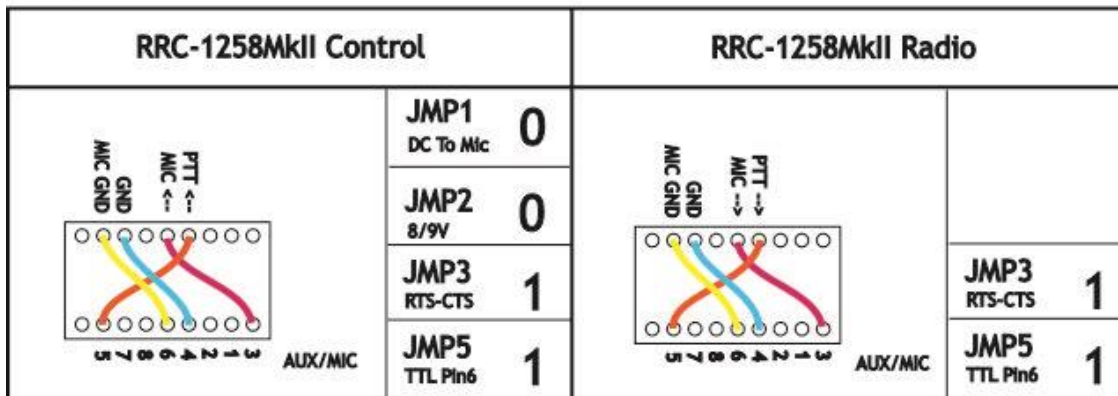

1 = In place, 0 = Not in place, X = doesn't matter

Radio settings (example)

Parameter	Control	Radio
Program mode	5 – TS480/TM-D710	5 – TS480/TM-D710
SIP password	hello	hello
SIP contact	192.168.0.228	
Auto connect	No	
Audio quality	2 – Linear 16 bits 8 kHz	2 – Linear 16 bits 8 kHz
Audio dual-rx (*)		No
Codec out gain	255	255
Codec inp gain	13	0
Codec inp preamp	Yes	
Codec HPF Hz	163	163
COM0 baudrate	57600	57600
COM0 data bits	8	8
COM0 stop bits	1	1
COM0 parity	0 - Off	0 - Off

*) Available only in RRC-1258MkIIs.

Connections

All necessary signals between the panel and the radio are connected with the 6 wires in the connection cable. In the package delivered by Kenwood there is a short and a long cable with RJ11 connectors which can be used. Convenient for travelling is that the speaker is already present on the back of the control panel so there is no need for an extra speaker, even if a separate speaker gives a much better audio. The following signals are represented in the connection cable (6-pol modular):

- 1 SPK GND - speaker ground
- 2 8V power to control panel (always present)
- 3 GND
- 4 RDO - serial data 57600 bps from radio to panel

- 5 TDO - serial data 57600 bps from panel to radio
- 6 AF - audio to speaker.

The short 6 wire cable with RJ11 connectors supplied by Kenwood should be used between the Radio and the Radio-RRC.

The long 6 wire cable with RJ11 connectors supplied by Kenwood should be used between the Control-RRC and the control panel.

The short black CAT-6 patch cable attached with the Remoterig can be used as mic connection between the Radio-RRC and the radio.

If the TS-480 is provided with a microphone with RJ-45 connector you can connect it directly to the AUX/MIC connector on the Control-RRC. Older TS-480 has a circular 8 pin connector then you have to use the adapter cable MJ-88 which was then supplied by Kenwood as a adapter between the Microphone and the AUX/MIC connector.

Connection type 1

Modular 8-pol connector:

- 3 MIC- mic Signal
- 4 MICE - mic ground
- 5 PTT
- 6 GND PTT

Connection type 2

Modular 8-pol connector:

- 3 MIC- mic Signal
- 4 GND PTT
- 5 PTT
- 6 MICE - mic ground

If you use the wrong configuration everything will work but the system will be very sensitive for HF (RFI).

Power supply

Control-RRC:

The Control-RRC is supplied with a common 13,8 V (10-18V) power supply. The display and speaker amplifier needs a lot of power so you need at least 1A.

Radio-RRC:

The Radio-RRC could be powered with a separate Power supply or the same as the radio. If you use the Radio PS make sure you have a 1A fuse on the output to the RRC. Do not connect it direct to a 20-40A PS the cable will melt if something happens.

DET. NR.	CNT.	NAME	DIMENSION	NOTE
CONSTR. DRAWN	CHECKED	STAND. OK	SCALE	REPLACED BY
MS			1:2	091123
				DATE
				100103
Kenwood cables TS-480 P panel -> RRC-1258MkII Separated Panel		DRAWING NR	1258 Cable K11 1(1)	

RRC-1258MkII

8-pol RJ 45 Con

Mic Inp
8-pol Circular

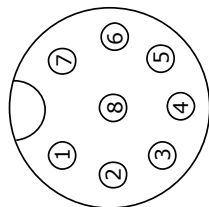

Same as Kenwood MJ-88

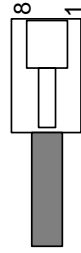
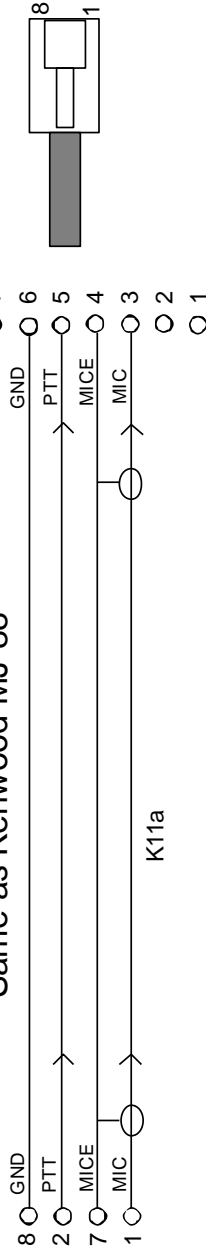

TS-480 Control Panel

6-pol modular

RRC 1258MkII TTL

6-pol modular

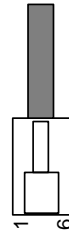
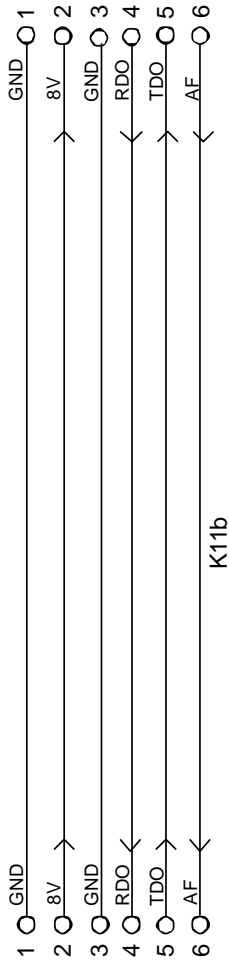

DET NR.	CNT	NAME		DIMENSION		NOTE
CONSTR.	DRAWN	CHECKED	STAND.	SCALE	REPLACE	REPLACED BY
MS			OK	1:2		
		Kenwood cables RRC-1258MkII -> TS-480 Radio Separated Panel				DRAWING NR
						1258 Cable K10 1(1)
						DATE
						100915

RRC-1258MkII
AUX/MIC

Mic Inp TS-480

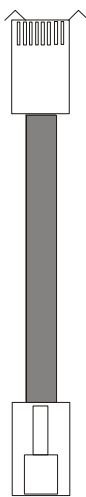

Try Standard shielded CAT 5

8-pol RJ 45 Con

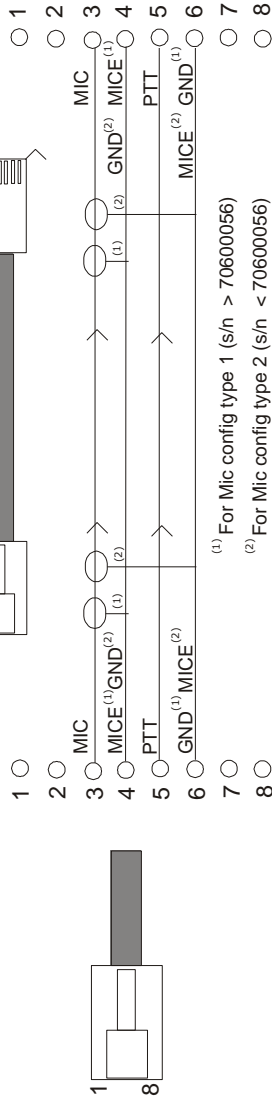

RRC-1258MkII TTL
6-pol modular

Control Inp TS-480
6-pol modular

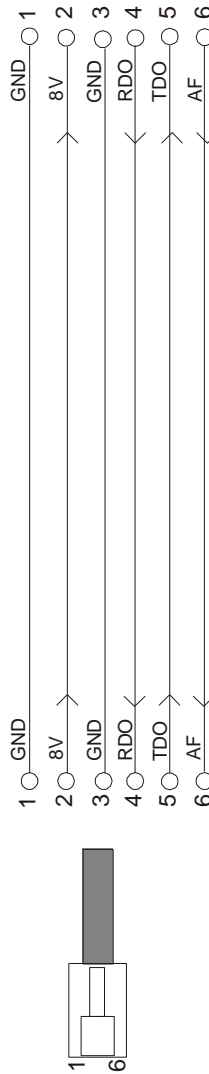

Logging, computer control, RRC-Micro, RRC-Nano control

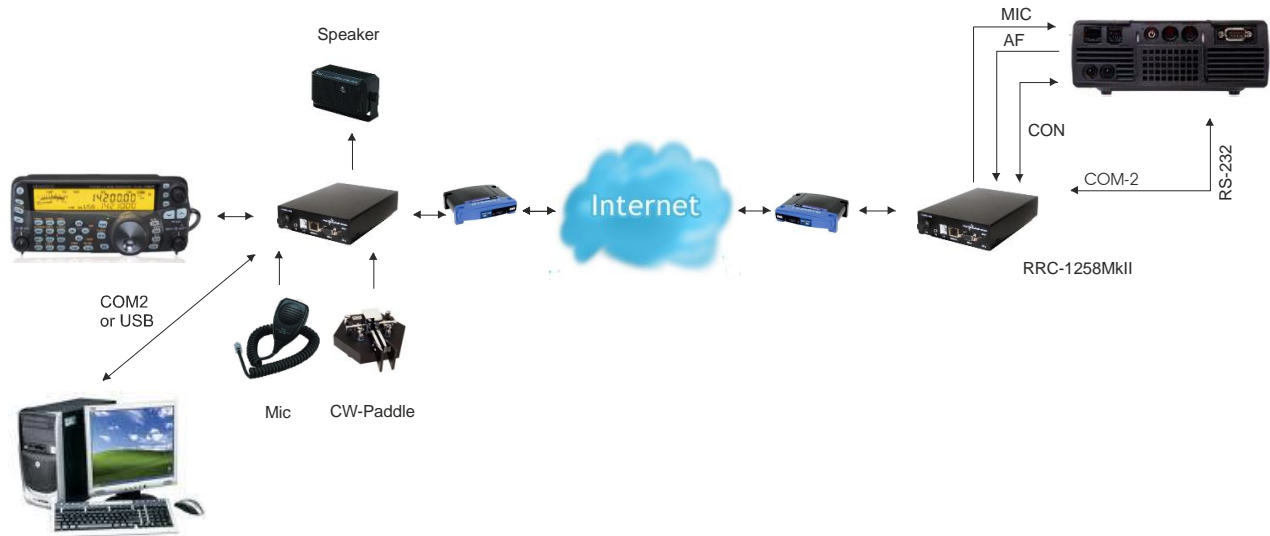

It's common to use a PC logbook software or PC control software connected to the radio, this can be done with the remote controlled TS-480 also. All PC-programs, the RRC-Micro software and the RRC-Nano App uses the Kenwood CAT protocol to talk to the radio, this protocol is only available via the CAT connector on the back of the radio. You need to connect a serial cable between the Radio-RRC com2 and the CAT connector on the Radio. The cable are available from Remoterig or can easily be made by yourself. The cable is a straight cable with two 9 pin D-sub, both female (not a Null modem cable).



9PF-----9PF
2-----2
3-----3
5-----5
7-----7
8-----8

Note!
JMP 3 in should be in place in the RRC:s

Remoterig Cable 1258-CAT-YK

Set the radio CAT baudrate to 9600 baud, this is done from the radio frontpanel. Setup the RRCs to match. If you only want to use RRC-Micro or RRC-Nano only the Radio-RRC settings

are needed. You have to decide if you want to use the RS-232 or the USB connector for the connection to the PC (Yes = USB, No = RS-232)

Parameter	Control-RRC	Radio-RRC
COM2 mode	Mode-4 Kenwood, Y.....	Mode-4 kenwood, Y.....
COM2 baudrate	9600	9600
COM2 data bits	8	8
COM2 stop bits	1	1
COM2 parity	0 - Off	0 - Off
Use USB Com Port as COM2	No/Yes	

It's more straightforward to use the Control-RRC physical Com2 on the front of the RRC if you do so you only need to know to which PC com port you connect the cable to when you select com port in your PC-software.

If you USB connection there will show up 4 virtual COM-ports in the Windows Device Manager when you connect the USB-cable. When you open the device manager you will see something like this.

- RRC1258 COM0 (COM47)
- RRC1258 COM1 (COM49)
- RRC1258 COM2 (COM46)
- RRC1258 COMExtra (COM48)

The values on within the parentheses is the COM-port number which Windows has assigned to each of the 4 RRC1258 virtual comports.

When you configure your PC program you should select the COM-port which is assigned to RRC1258 COM2, in the example above it's COM46.

Serial server function

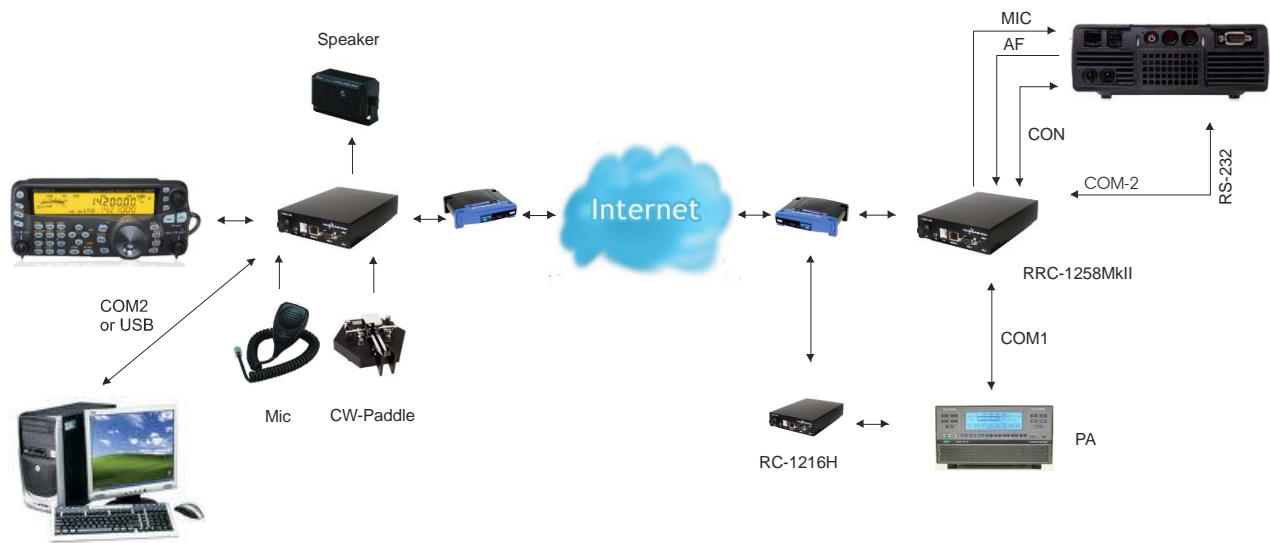

If you also need a connection for a PA or something which have to talk to the radio, it can be connected to Radio-RRC COM1 then the data will be mixed (under control) so both the PC and the PA can talk to the radio. Be aware of the pin configuration of COM1 it's not the same as for COM2

Parameter	Control-RRC	Radio-RRC
COM1 mode	Inactive	Mode-6 CAT to COM2 (local)
COM1 baudrate		9600
COM1 data bits		8
COM1 stop bits		1
COM1 parity		0 - Off

KENWOOD TM-D710(GE) /TM-V71

General

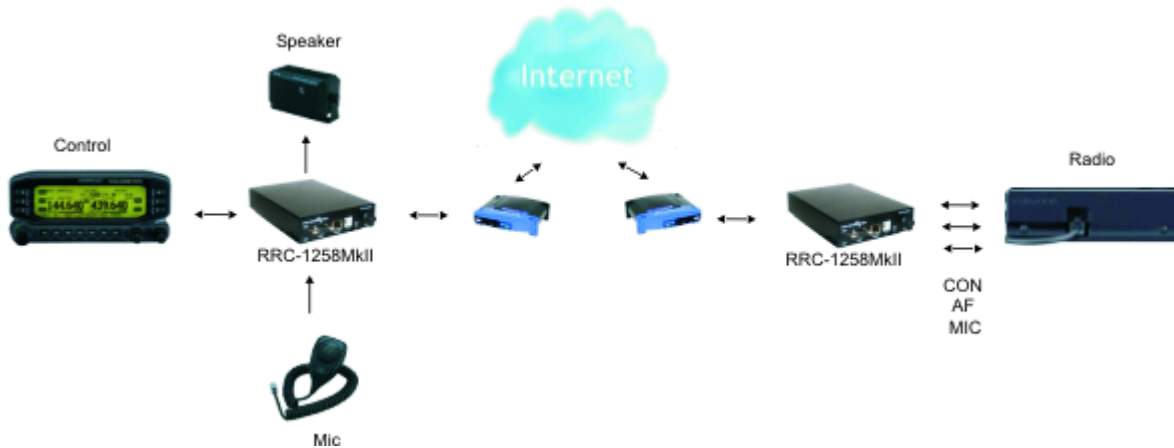

The Kenwood TM-D710(GE) and TM-V71 is modern dual band FM-transceivers with separate control panel which is perfect for remote control via Internet. The idea of remote controlling TM-D710 and TM-V71 is simple; it's just to extend the cord between the radio and the control panel using Internet. When you press the power button on the panel the radio comes to life at the remote side and sound and panel info flows across the Internet between the pair of RRC-1258MkII:s. The look and feel of the panel is the same as if the panel was directly connected to the radio.

Hardware configuration

It's very simple to Interface the TM-D710 / TM-V-71 for remote control via the RRC:s. You only need to make two simple cables. One from the Control panel to the Control-RRC and one from the Radio-RRC to the Radio. The standard mic (MC-59) provided with the TM-D710 /TM-V71 can be used and connected directly to the Control-RRC. From Radio-RRC to Radio normally a standard shielded FTP patch cable can be used for the Mic-signals. A standard audio cable with 1/8" inch connectors are used for the audio. A speaker are also needed as there is no speaker in the Control panel.

All software settings are the same as for TM-D710 and TM-V71, The only thing which is different is the cable between the Control panel and the Control-RRC. (see drawings below).

Remember that the buttons on the microphone will not work. If you need DTMF use an other Mic with built in DTMF encoder. The MC-59 do not have it. It's also possible to program DTMF functions to the radio which will available from the Control panel. Packet and APRS functions are not tested, normally used functions works as in the normal setup.

Kenwood TM-D710/TM-D700

RRC-1258MkII Control		RRC-1258MkII Radio	
	JMP1 DC To Mic	0	
	JMP2 8/9V	0	
	JMP3 RTS-CTS	1	
	JMP5 TTL Pin6	1	
<p>1 = In place, 0 = Not in place, X = doesn't matter</p>			

Radio settings (example)

Parameter	Control	Radio
Program mode	5 – TS480/TM-D710/TM-V71	5 – TS480/TM-D710/TM-V71
SIP password	hello	hello
SIP contact	192.168.0.228	
Auto connect	No	
Audio quality	2 – Linear 16 bits 8 kHz	2 – Linear 16 bits 8 kHz
Audio dual-rx (*)		No
Codec out gain	255	255
Codec inp gain	13	0
Codec inp preamp	Yes	
Codec HPF Hz	163	163
COM0 baudrate	57600	57600
COM0 data bits	8	8
COM0 stop bits	1	1
COM0 parity	0 - Off	0 - Off

*) Available only in RRC-1258MkIIs.

Power supply

Control-RRC:

The Control-RRC is supplied with a common 13,8 V (10-18V) power supply. The display and speaker amplifier needs a lot of power so you need at least 1A.

Radio-RRC:

The Radio-RRC could be powered with a separate Power supply or the same as the radio. If you use the Radio PS make sure you have a 1A fuse on the output to the RRC. Do not connect it direct to a 20-40A PS the cable will melt if something happens.

DET. NR.	CNT	NAME		DIMENSION		NOTE	
CONSTR.	DRAWN	CHECKED	STAND.	SCALE	REPLACE	REPLACED BY	
MS			OK	1:2			
		Kenwood TM-D710 cables Control => RRC-1258MkII				DATE	
						110103	
						DRAWING NR	
						1258 Cable K17 1(1)	

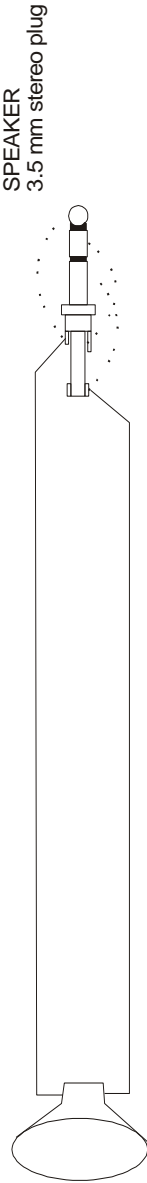

Control Panel TM-D710
8-pol RJ 45 Con

RRC-1258MkII TTL
4/6-pol modular

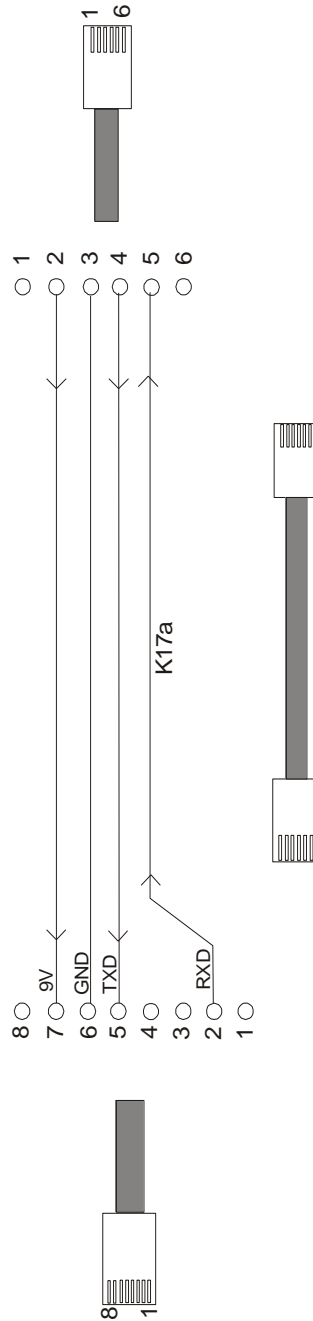

DET NR.	CNT	NAME	DIMENSION	NOTE
CONSTR.	DRAWN	CHECKED/ STAND.	SCALE	REPLACE
MS		OK	1:2	REPLACED BY
		Kenwood cable TM-V71 Panel -> RRC-1258MkII		DATE
				140217
			DRAWING NR	
			1258 Cable K13	1(1)

SPEAKER
3.5 mm stereo plug

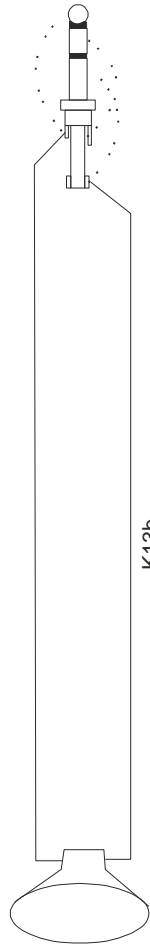

K13b

RRC-1258MkII TTL
4/6-pol modular

Control Panel TM-V71
4-pol Modular 4/4

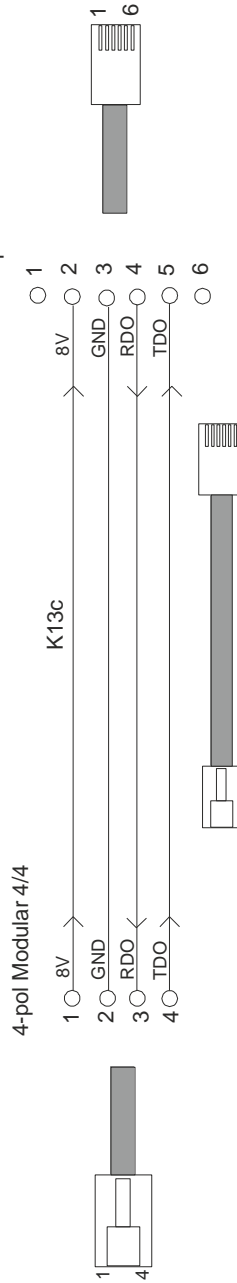

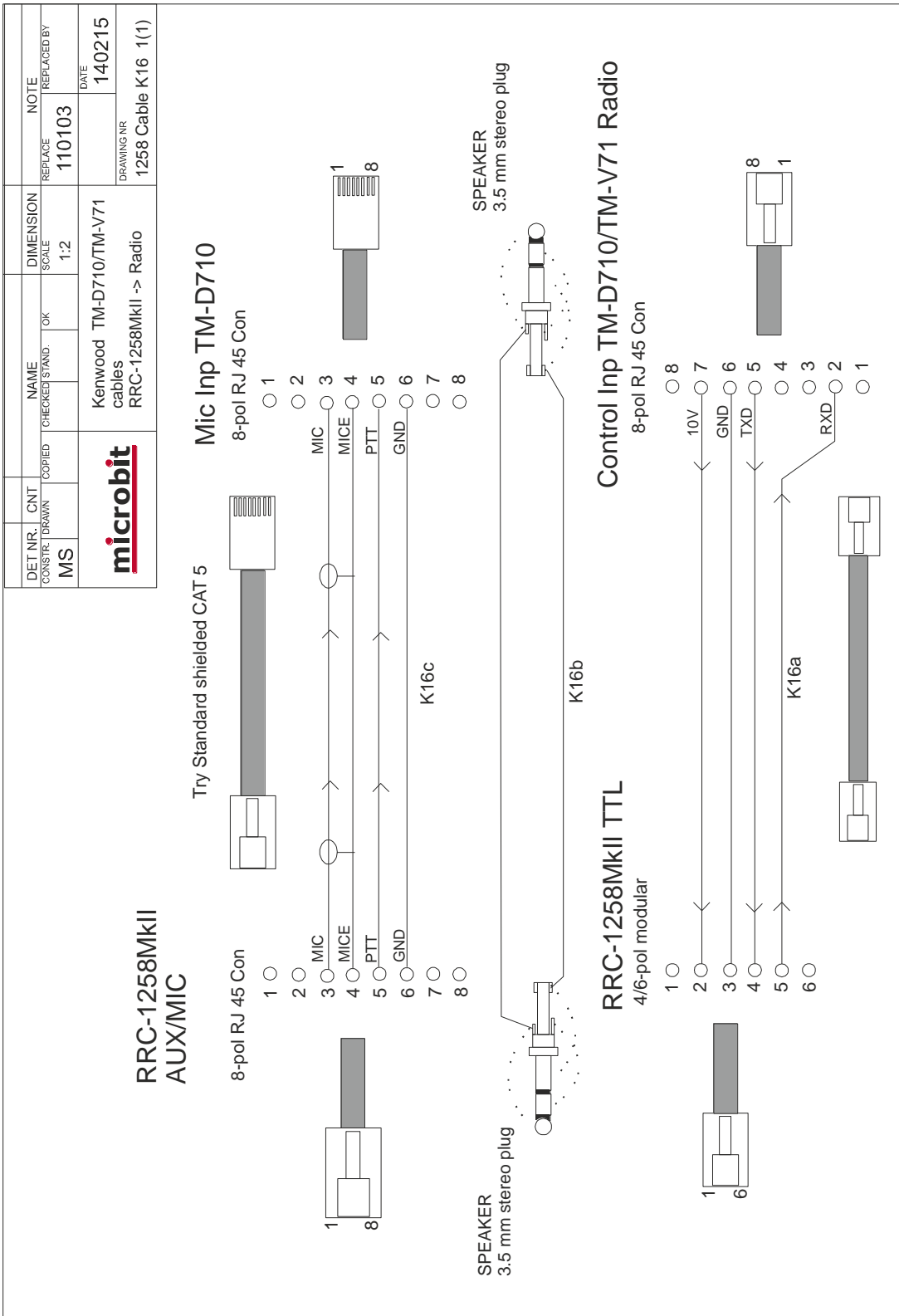

KENWOOD TM-D700

General

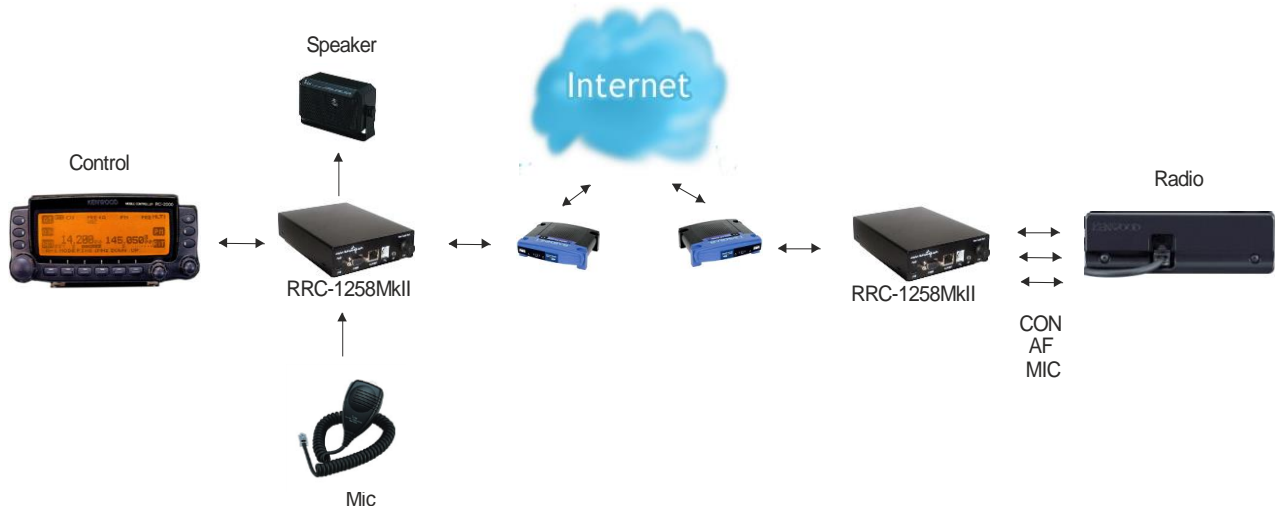

The Kenwood TM-D700 is a dual band FM-transceiver with separate control panel which is perfect for remote control via Internet. The idea of remote controlling TM-D700 is simple; it's just to extend the cord between the radio and the control panel using Internet. When you press the power button on the panel the radio comes to life at the remote side and sound and panel info flows across the Internet between the pair of RRC-1258MkII:s. The look and feel of the panel is the same as if the panel was directly connected to the radio.

Hardware configuration

It's very simple to Interface the TM-D700 for remote control via the RRC:s. You only need to make two simple cables. One from the Control panel to the Control-RRC and one from the Radio-RRC to the Radio. The standard mic (MC-53DM) provided with the TM-D700 can be used and connected directly to the Control-RRC. From Radio-RRC to Radio normally a standard shielded FTP patch cable can be used for the Mic-signals. A standard audio cable with 1/8" inch connectors are used for the audio. A speaker is also needed as there is no speaker in the Control panel.

Remember that the function buttons on the microphone will not work but. The DTMF buttons are working. The Packet radio functions are not tested but the normally used functions works as in the normal setup.

Kenwood TM-D710/TM-D700

RRC-1258MkII Control		RRC-1258MkII Radio	
	JMP1 DC To Mic	0	
	JMP2 8/9V	0	
	JMP3 RTS-CTS	1	
	JMP5 TTL Pin6	1	
	JMP3 RTS-CTS	1	
	JMP5 TTL Pin6	1	

1 = In place, 0 = Not in place, X = doesn't matter

Radio settings (example)

Parameter	Control	Radio
Program mode	8 - TS-2000/TM-D700	8 - TS-2000/TM-D700
SIP password	hello	hello
SIP contact	192.168.0.228	
Auto connect	No	
Audio quality	2 - Linear 16 bits 8 kHz	2 - Linear 16 bits 8 kHz
Audio dual-rx (*)		No
Codec out gain	255	255
Codec inp gain	13	0
Codec inp preamp	Yes	
Codec HPF Hz	163	163
COM0 baudrate	57600	57600
COM0 data bits	8	8
COM0 stop bits	1	1
COM0 parity	0 - Off	0 - Off

*) Available only in RRC-1258MkIIs.

Power supply

Control-RRC:

The Control-RRC is supplied with a common 13,8 V (10-18V) power supply. The display and speaker amplifier needs a lot of power so you need at least 1A.

Radio-RRC:

The Radio-RRC could be powered with a separate Power supply or the same as the radio. If you use the Radio PS make sure you have a 1A fuse on the output to the RRC. Do not connect it direct to a 20-40A PS the cable will melt if something happens.

DET. NR.	CNT	NAME		DIMENSION		NOTE	
CONSTR.	DRAWN	CHECKED	STAND.	SCALE	REPLACE	REPLACED BY	
MS				1:2			
		Kenwood cable RC-panel -> RRC-1258MKII				DATE	
						11.12.20	
						DRAWING NR	
						1258 Cable K13 1(1)	

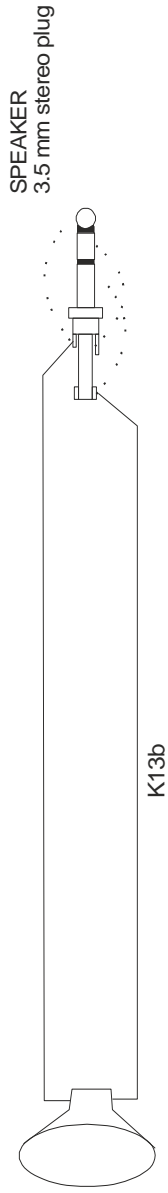

RRC-1258MKII TTL
4/6-pol modular

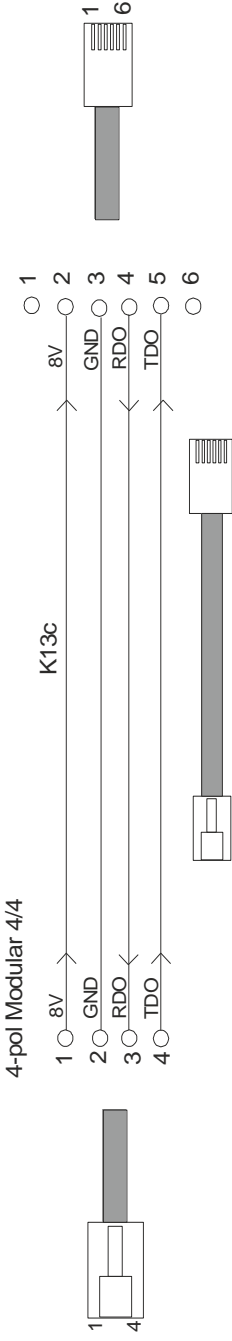

KENWOOD TS-2000

General



The technical solution for TS-2000 is the same as for TS-480 and IC-706 with the different that TS-2000 has a special control panel witch works in parallel with the front panel control on the radio. If you have the TS-2000 at your summer QTH you do not need to take the control panel with you when you want to use the TS-2000 locally. We replace the cable between panel and radio with to RRC-1258, one connected to the control panel and one connected to the radio. When you press the power button on the panel the radio comes to life at the remote side and audio and panel info flows across the internet between the RRC:s. The look and feel of the control panel is the same as if the panel was directly connected to the radio.

Hardware configuration

Kenwood

RRC-1258MkII Control		RRC-1258MkII Radio	
AUX/MIC Configuration 	JMP1 DC To Mic	0	AUX/MIC Configuration
	JMP2 8/9V	0	
	JMP3 RTS-CTS	1	
	JMP5 TTL Pin6	1	

1 = In place, 0 = Not in place, X = doesn't matter

Radio settings (example)

Parameter	Control	Radio
Program mode	8 - TS2000	8 - TS2000
SIP password	hello	hello
SIP contact	192.168.0.228	
Auto connect	No	
Audio quality	2 - Linear 16 bits 8 kHz	2 - Linear 16 bits 8 kHz
Audio dual-rx (*)	-	Yes
Codec out gain	255	255
Codec inp gain	13	0
Codec inp preamp	Yes	
Codec inp HPF Hz	163	163
COM0 baudrate	57600	57600
COM0 data bits	8	8
COM0 stop bits	1	1
COM0 parity	0 - Off	0 - Off

(*) Available only in RRC-1258MkIIs, remember that the bandwidth demand is doubled.

Connections

The TS-2000 is quite simple to connect because you do not need any special cable. All necessary signals between the panel and the radio are connected with the 4 wires in the connection cable. We just need to cut it apart and connect a RRC-1258MkII in each end. The following signals are represented in the connection cable (modular):

RJ12 Modular 4/6 Radio	RJxx Modular 4/4 Control panel	Description
1		
2	1	8V power to control panel (always present)
3	2	GND
4	3	RDO - serial data 57600 bps from radio to panel
5	4	TDO - serial data 57600 bps from panel to radio
6		

The easiest way to make these two cables from control panel to Control-RRC TTL connector and from Radio-RRC TTL connector to radio is to cut the cable supplied by Kenwood into two pieces. You only have to crimp two new 4/6 modular connectors on the cables. Don't make the one between Radio-RRC and radio too long.

The long microphone extension cable supplied by Kenwood can also be used between Radio-RRC AUX/MIC connector to the radio Microphone jack. Probably you need to cut it later to prevent it from picking up HF from your antennas.

The microphone can be connected to the Control-RRC AUX/MIC connector using the adapter cable MJ-88 supplied by Kenwood with your TS-2000.

The speaker supplied with the TS-2000 is connected to the 3.5 mm SP-jack on the front of the Control-RRC.

The speaker signal from the TS-2000 ext. speaker jack to the Radio-RRC SP jack is connected via a standard "off-the-shelf" cable with 3.5 mm stereo plugs in both ends.

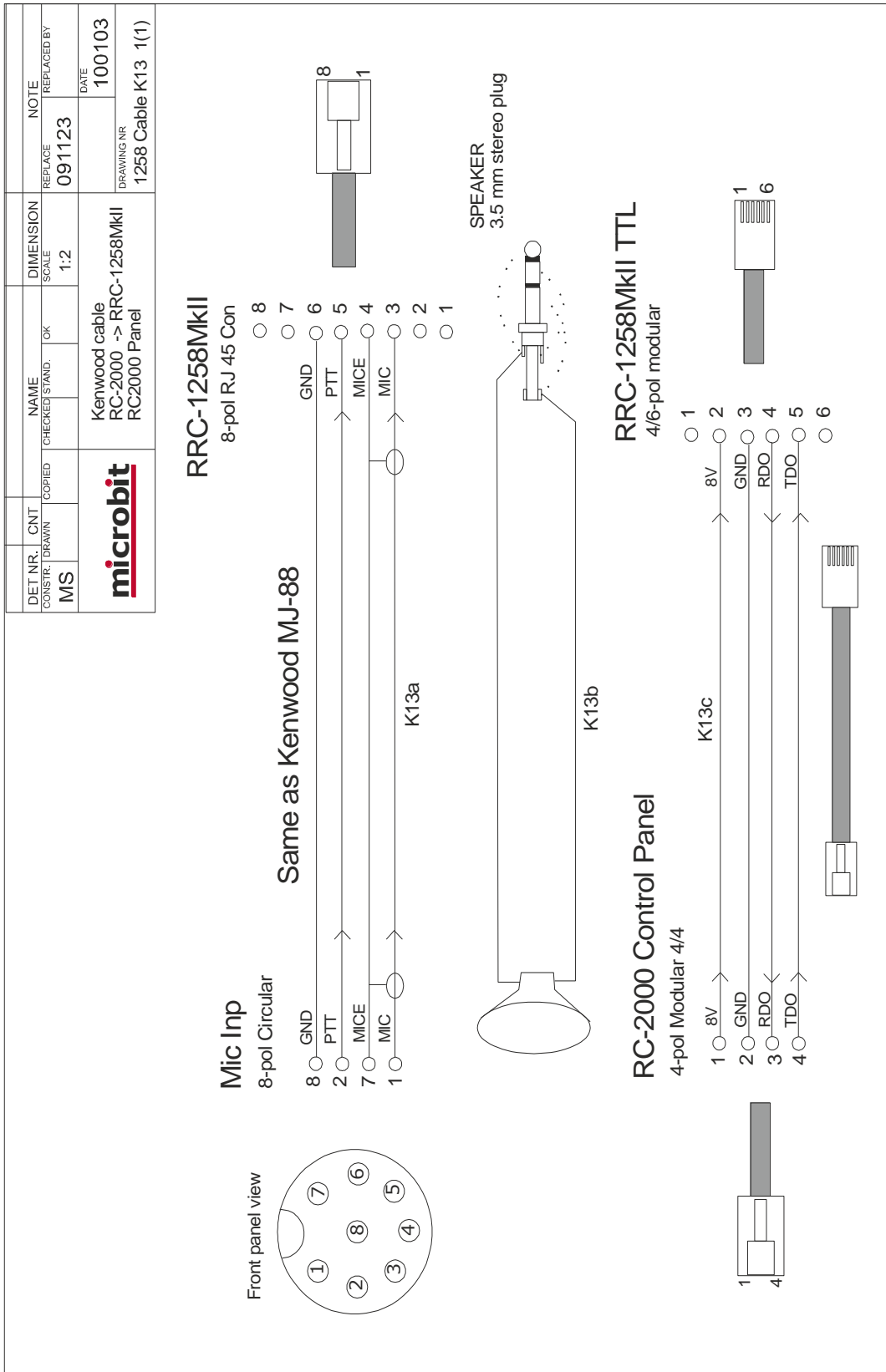

DET. NR.	CNT	NAME	DIMENSION	NOTE
CONSTR. DRAWN	CHECKED	STAND. OK	SCALE	REPLACE
MS			1:2	091123
			DATE	100915
Kenwood cable RRC-1258MkII -> TS-2000 RC-2000 Panel			DRAWING NR	1258 Cable K12 1(1)

RRC-1258MkII
8-pol RJ 45 Con

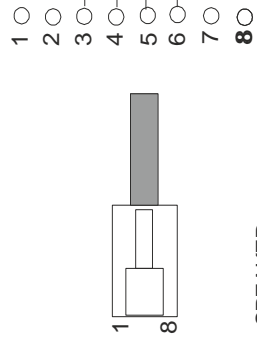

Mic Inp
8-pol Circular

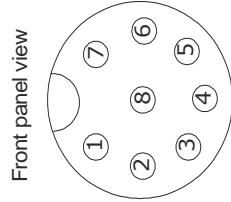

SPEAKER
3.5 mm stereo plug

SPEAKER
3.5 mm stereo plug

RRC-1258MkII TTL
4/6-pol modular

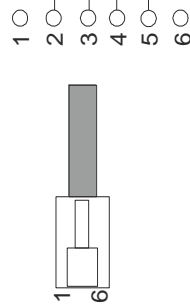

Control Inp TS-2000
4/6-pol modular

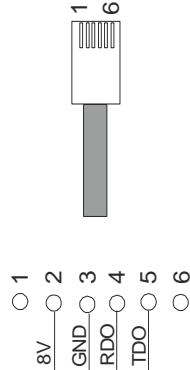

Kenwood TS-590S(G)-Twin

General

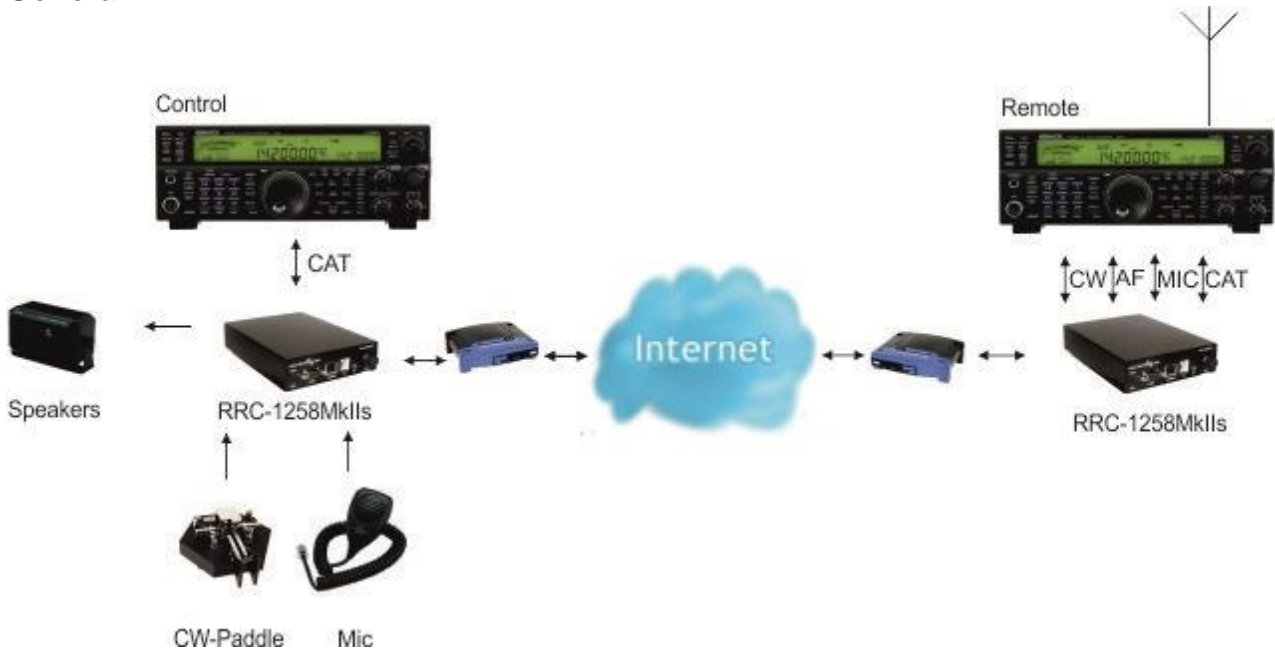

Finally we have implemented firmware for the Remoterig RRC-1258MkIIs to support Kenwood TS-590 in a twin setup like we have done for Elecraft and Yaesu before

The TS-590 twin concept can be setup with the ordinary RRC-1258MkIIs, you only need new firmware and cables.

The overall functionality is very good, most functions are working except the SWR/ALC/COMP meter which can't be controlled via CAT, We hope Kenwood will implement support for this. The lack of SWR readings makes the use of autotuner a bit difficult but if you use a PC-control software in parallel you can see the SWR/ALC/COMP meters there.

Note ! Two TS 590S or two TS-590SG can be used in pair, the models cannot be mixed as the protocols for the two versions is different.

A Video is available her showing the setup

http://www.remoterig.com/downloads/IMG_1071.MOV

Hardware configuration

Strapping is standard kenwood
Kenwood

RRC-1258MkII Control		RRC-1258MkII Radio	
AUX/MIC Configuration 	JMP1 DC To Mic 0	AUX/MIC Configuration 	
	JMP2 8/9V 1		
	JMP3 RTS-CTS 1		JMP3 RTS-CTS 1
	JMP5 TTL Pin6 1		JMP5 TTL Pin6 1
1 = In place, 0 = Not in place, X = doesn't matter			

Setup

Set both TS-590 CAT-baudrate to 19200 baud (menu 56).

Parameter	Control	Radio
Program mode	18 – Kenwood TS-590 Twin	18 – Kenwood TS-590 Twin
SIP password	hello	hello
SIP contact	192.168.0.228	
Auto connect	No	
Audio quality	2 – Linear 16 bits 8 kHz	2 – Linear 16 bits 8 kHz
Audio dual-rx		No
Codec out gain	255	255
Codec inp gain	18	0
Codec inp preamp	Yes	
Codec inp HPF Hz	163	163
COM0 baudrate	19200	19200
COM0 data bits	8	8
COM0 stop bits	1	1
COM0 parity	0 - Off	0 - Off
COM2 mode	Logical parallel with COM0	Logical parallel with COM0

Note! When you power on the system lot of data has to be transferred between the two radios, during that time the display backlight is blinking.

Connections

Microphone, paddles, key, speakers etc. should be connected to the Control-RRC only the CAT cable should be connected to the Control Radio.

A good idea is to put dummyloads to the Control Radio to avoid trouble if you use the autotuning buttons.

Drawings of the cables can be found below

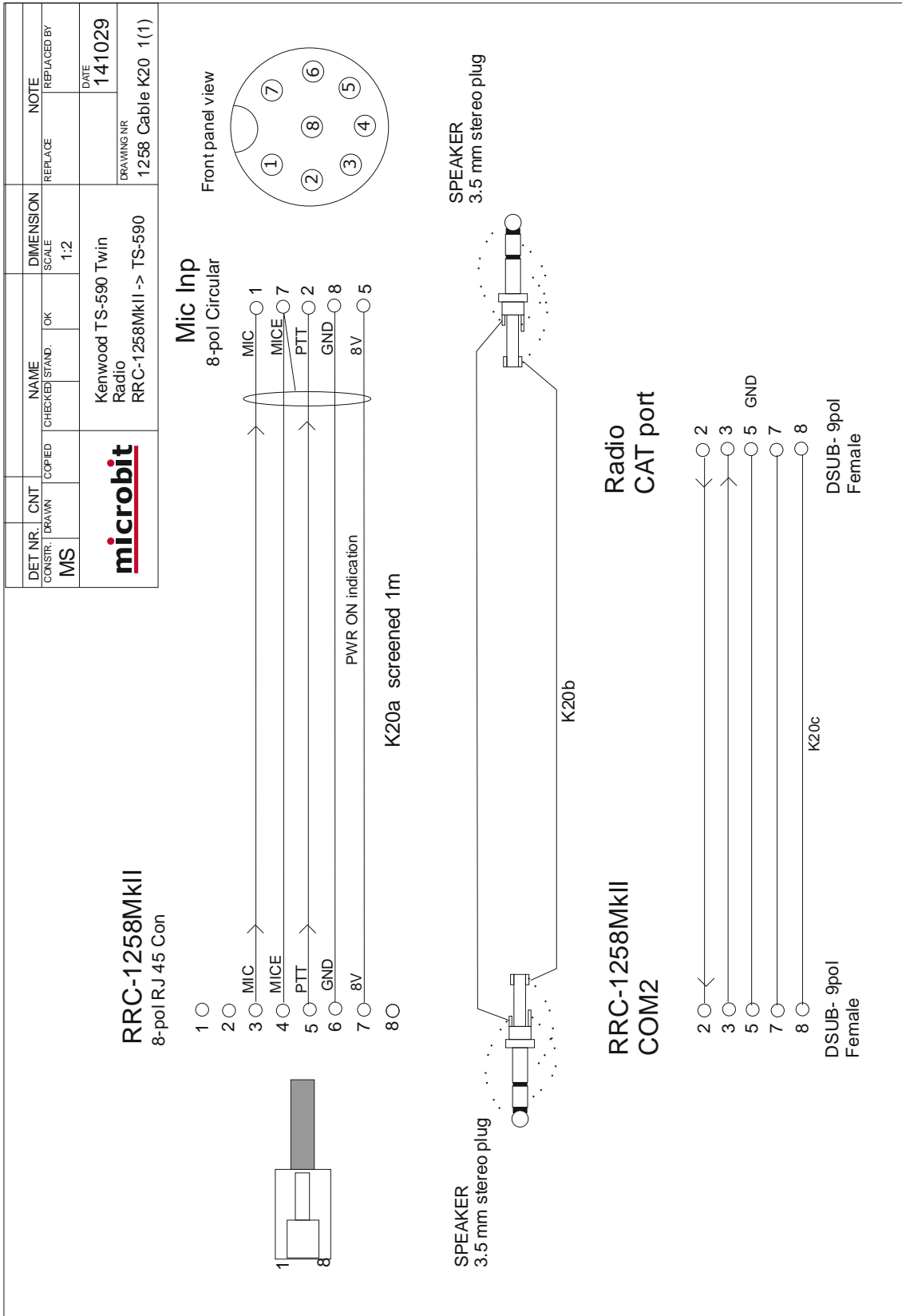

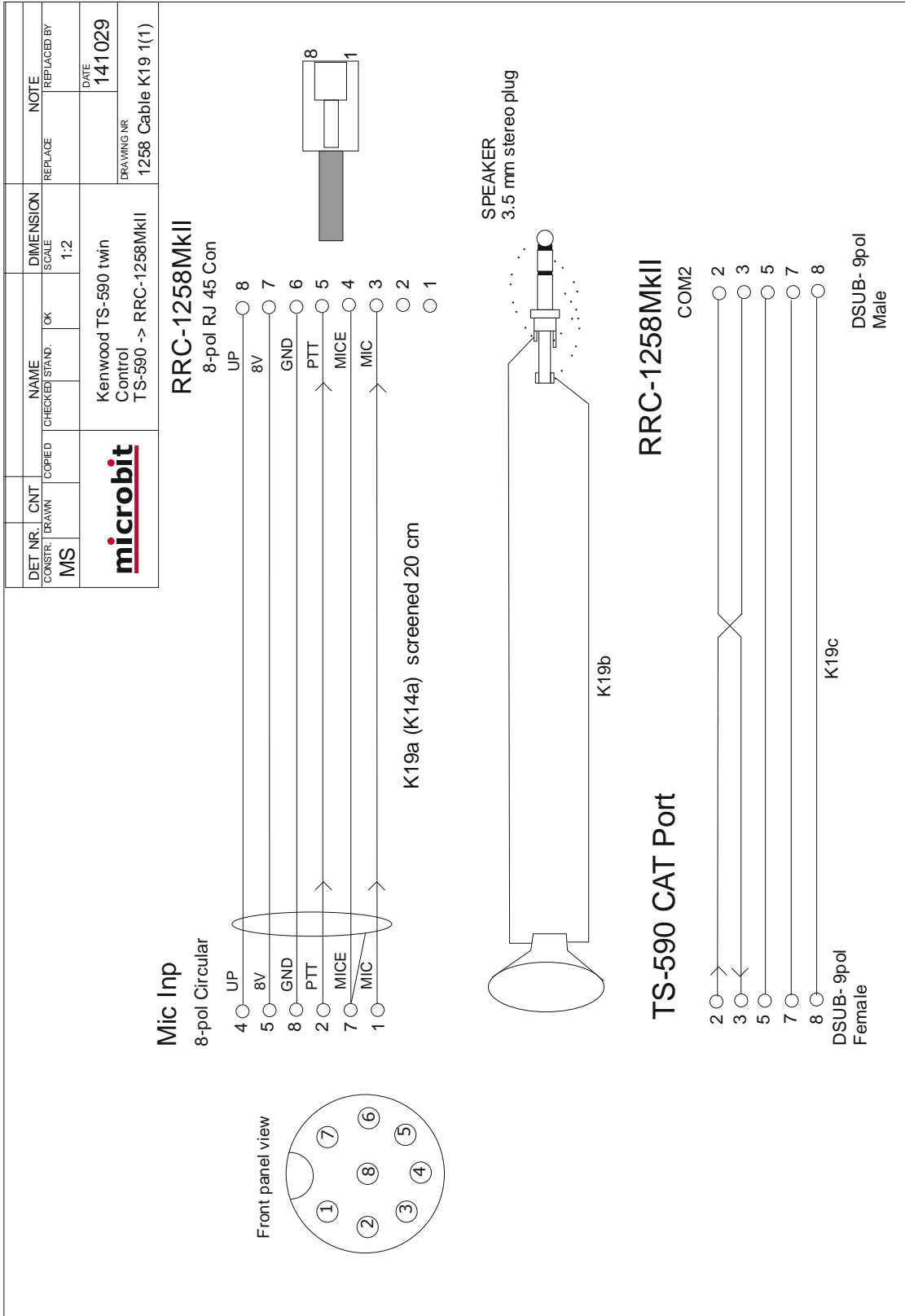

ELECRAFT K3-Twin

General

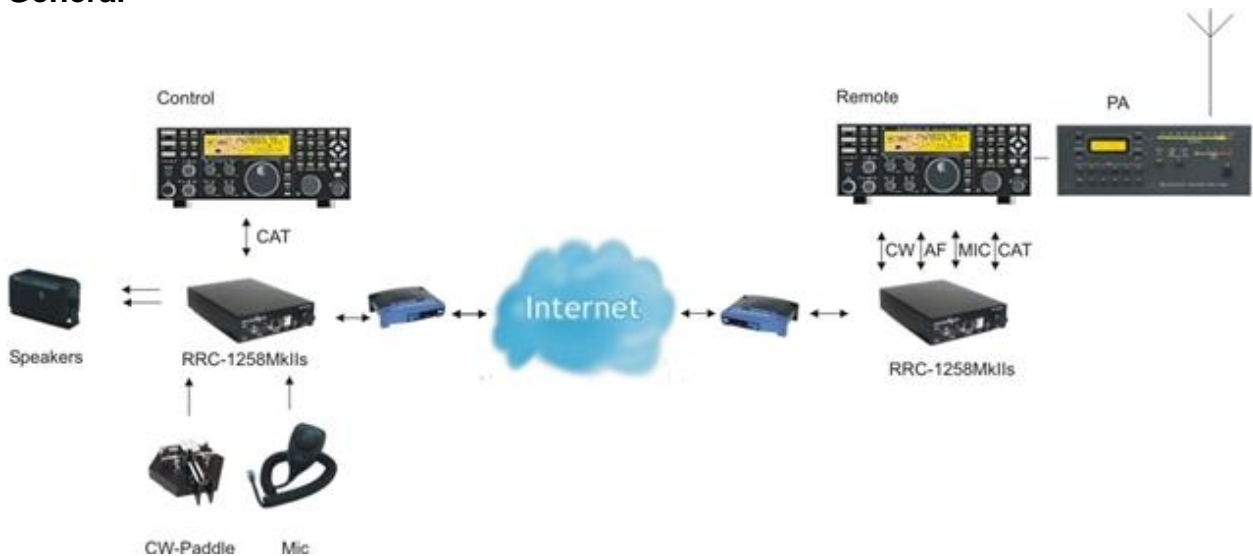

RRC-1258MkIIIs supports the special high end concept where one Elecraft K3 radio can be used to control another Elecraft K3 radio. From Jan 2012 there is also a specially designed "control radio" called K3/0 available from Elecraft which has no RF-parts. No PC:s needed at either end. The functionality is perfect as Elecraft has added support in their software specially for this purpose. The control radio is not used other than as a terminal so it doesn't matter how it's configured. It can be the K3/0 or the simplest K3/10 without any options even if the remote K3 is loaded with all extras. The RRC-1258MkIIIs Elecraft Twin package includes all necessary cables. The boxes do not need to be opened all strappings are done in production. All you need to do is to put the system together and do the IP-settings. The ordinary RRC-1258MKIIIs can also be configured to be used for Elecraft K3 twin.

Hardware configuration

In the standard RRC:s the strappings are done manually by the customer, but In the RRC-1258MkIIIs Elecraft K3 Twin package the strappings are done by a small pcb marked 1258KE which is assembled at the strapping area. The small pcb is removable if you later want to use the RRC:s for some other configuration. When you replace it is important that the notch which marks pin one is placed according to the picture below.



For your reference the picture below shows how the strappings are done on the small pcb.

Elecraft K3

RRC-1258MkII Control		RRC-1258MkII Radio	
	JMP1 DC To Mic	1	
	JMP2 8/9V	1	
	JMP3 RTS-CTS	1	
	JMP5 TTL Pin6	1	

1 = In place, 0 = Not in place, X = doesn't matter

JMP1 should be in place when using Elecraft MH2 Mic and removed when using for example Heil headset.

Radio settings (example)

Parameter	Control	Radio
Program mode	14 – Elecraft K3 twin	14 – Elecraft K3 twin
SIP password	hello	hello
SIP contact	192.168.0.228	
Auto connect	No	
Audio quality	2 – Linear 16 bits 8 kHz	2 – Linear 16 bits 8 kHz
Audio Dual-RX	-	Yes/No (*1)
Codec out gain	255	255
Codec inp gain	14	0
Codec inp preamp	Yes	
Codec inp HPF Hz	163	163
COM0 baudrate	38400 (*2)	38400 (*2)
COM0 data bits	8	8
COM0 stop bits	1	1
COM0 parity	0 - Off	0 - Off
COM2 mode	Logical parallel with COM0	Logical parallel with COM0
OUT0	-	Connect

(*1) Available only in RRC-1258MkIIs, remember that the bandwidth demand is doubled.

(*2) Set the CAT speed in both Radios also to 38400 baud.

Connections

Drawings of the connection cables can be found below.

All necessary cables are included in the package.

Control site



- 1 Connect 12V power supply to the PWR jack
- 2 Connector Ethernet to the Ethernet jack (2m CAT 5 cable included)
- 3 Connect the CAT cable E1d from the RRC COM2 connector to the K3 CAT connector
- 4 Connect the microphone via the Microphone adapter cable E1a
- 5 Connect speaker to the speaker jack, If you want separate audio from the sub-rx you need two speakers, the speaker for the sub-rx must be active. (speakers and cable are not included)
- 6 Connect paddle to the PAD jack (adapter from ¼" connector to 3.5 mm included)

Radio site

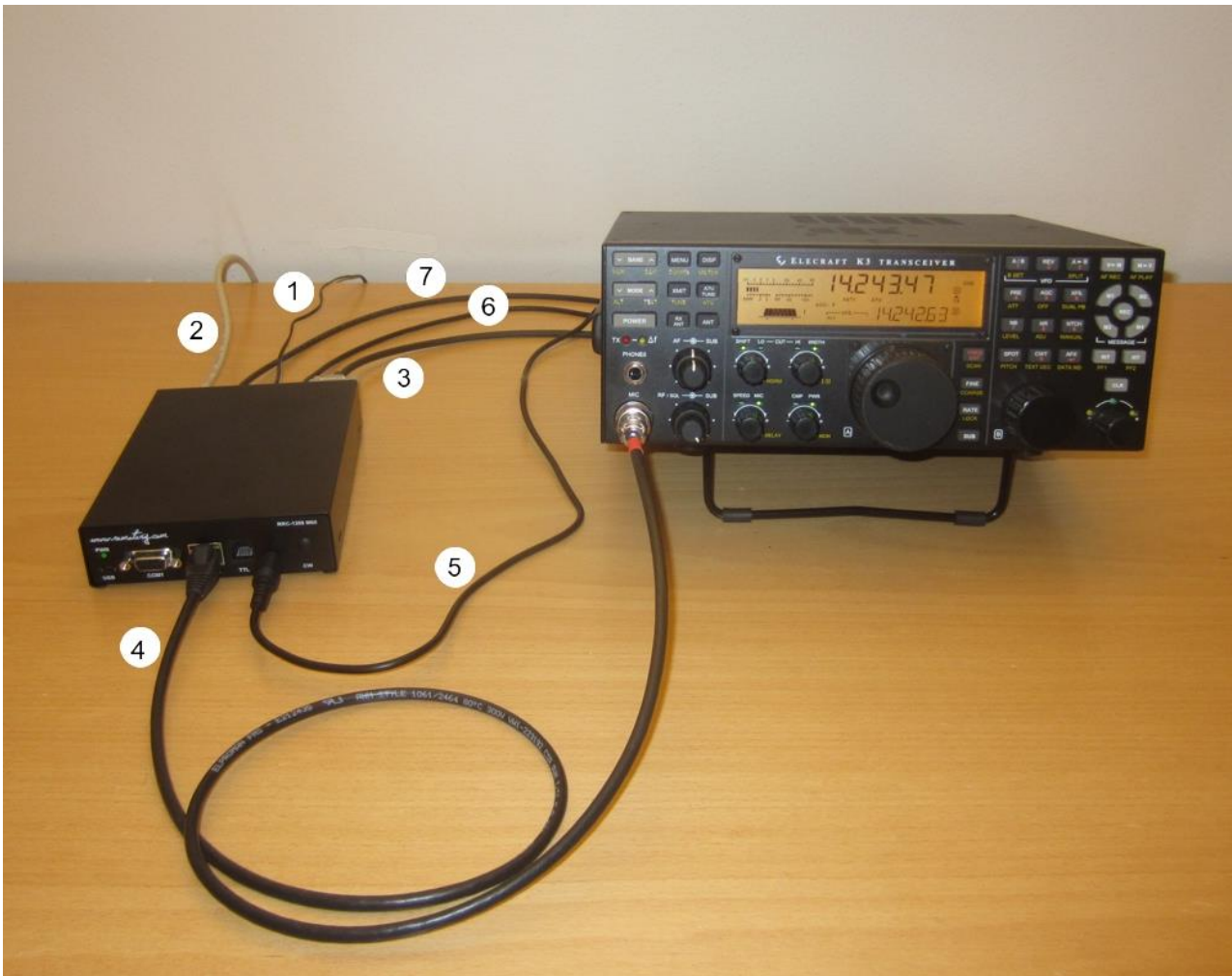

- 1 Connect 12V power supply to the PWR jack
- 2 Connector Ethernet to the Ethernet jack (2m CAT 5 cable included)
- 3 Connect the CAT cable E2c from the COM2 connector to the K3 CAT connector
- 4 Connect the mic cable E2a from the AUX/MIC jack to the K3 mic connector.
- 5 Connect the audio cable from to the SP jack to the K3 speaker out on the back output.
- 6 Connect the keying cable from the PAD jack to the K3 key input (Adapter from 1/4" connector to 3.55 mm included)

Logging or computer control, RTTY etc.

Even if the CAT connector at the Remote K3 is occupied with the communication between the two K3:s it is possible to connect other equipment to the system due to an intelligent CAT server functionality in the RRC.s. If you need to connect a antenna switch for example which need to talk to the remote K3 you can connect it to the Radio-RRC COM1 and configure COM1 to "Mode 6, CAT to COM2 (local)".

If you want to connect a logging or PC-control software to the system you can connect it to the Control-RRC COM1 via RS-232 or USB and configure both RRC:s COM1 to "Mode-7, CAT to COM2 (local&remote)". Then all commands go to and from the Remote K3 over the network. You can still use the remote antenna switch as described above.

Independent of the connections above you can use the K3:s FSK transmission. Configure Radio-RRC "OUT1 mode = Baudot/45" and use the Virtual USB port COMExtra for the RTTY software. The supplied ACC cable are wired to key the K3 FSK input.

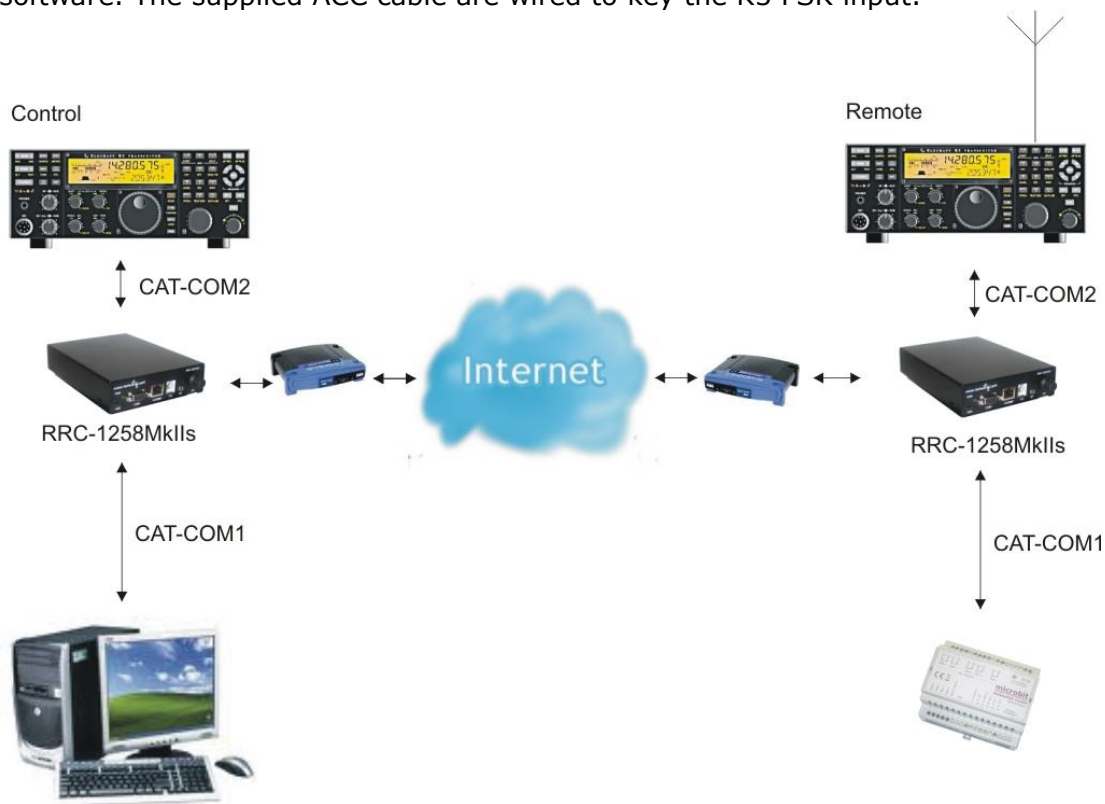



Cable E1d – Control K3 to Control-RRC
COM2
9PF-9PF



Cable E2c – Radio-RRC COM2 to Remote K3
9PM-9PF



Cable E3c – I/O to K3 ACC jack



Adapter 3.5 mm to 1/4" Paddle input adapter to
remote radio



Cable E1a – Mic to Control-RRC Mic jack



Cable E2a – Radio-RRC Mic jack to K3 Mic
input



Cable 3.5 mm – 3.5 mm Audio Output from Remote radio to Radio-RRC SP input jack



Cable 3.5 mm – 3.5 mm Keyer from Radio-RRC PAD jack to Remote radio straight key input jack



Adapter 1/4" to 3.5 mm Headset adapter



Adapter 1/4" to 3.5 mm Paddle adapter

DET NR.	CNT	NAME	DIMENSION	NOTE
CONSTR.	DRAWN	CHECKED/STAND.	SCALE	REPLACE
MS		OK		REPLACED BY
		Electcraft Twin cables Control K3 to Control-RRC		
		DRAWING NR	DATE	
		1258 Cable E1 1(1)		

RRC1258MkII AUX/MIC
8Pol RJ45 Con

Mic Inp
8-pol Circular

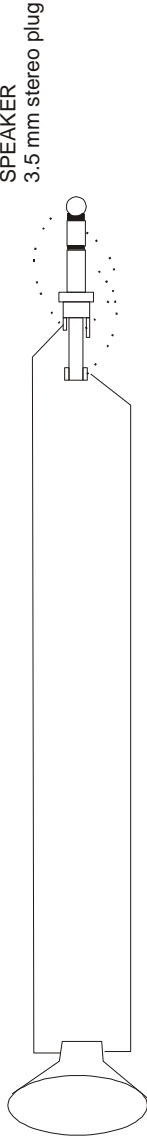
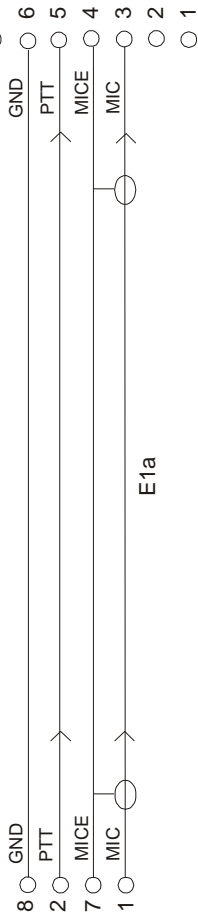
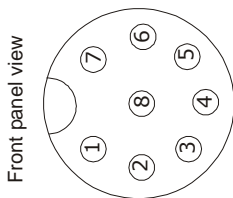

K3 Radio RS-232 portCOM2
DSUB- 9pol
Male

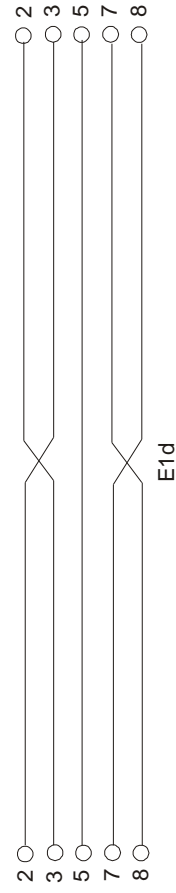

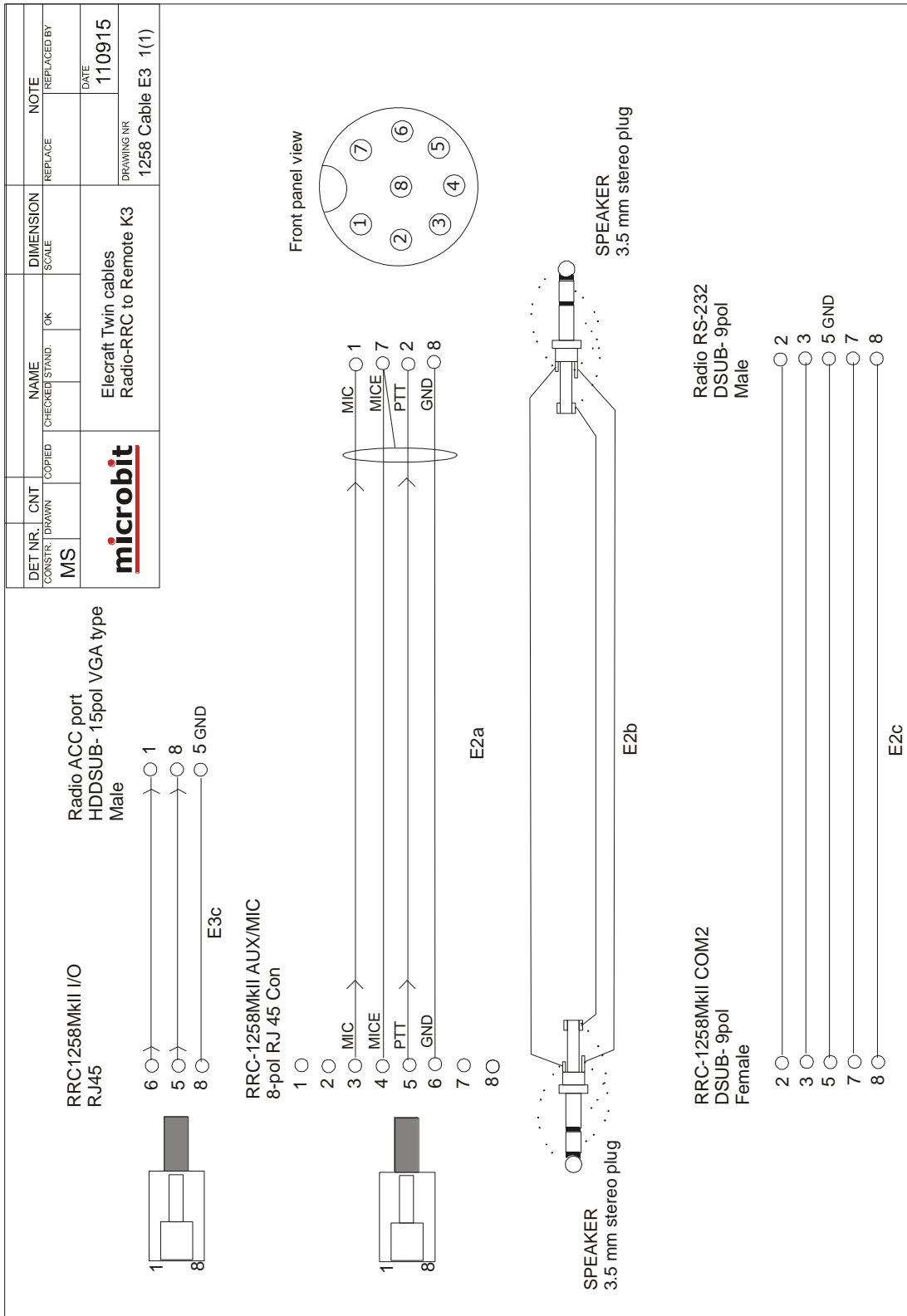

ELECRAFT

General

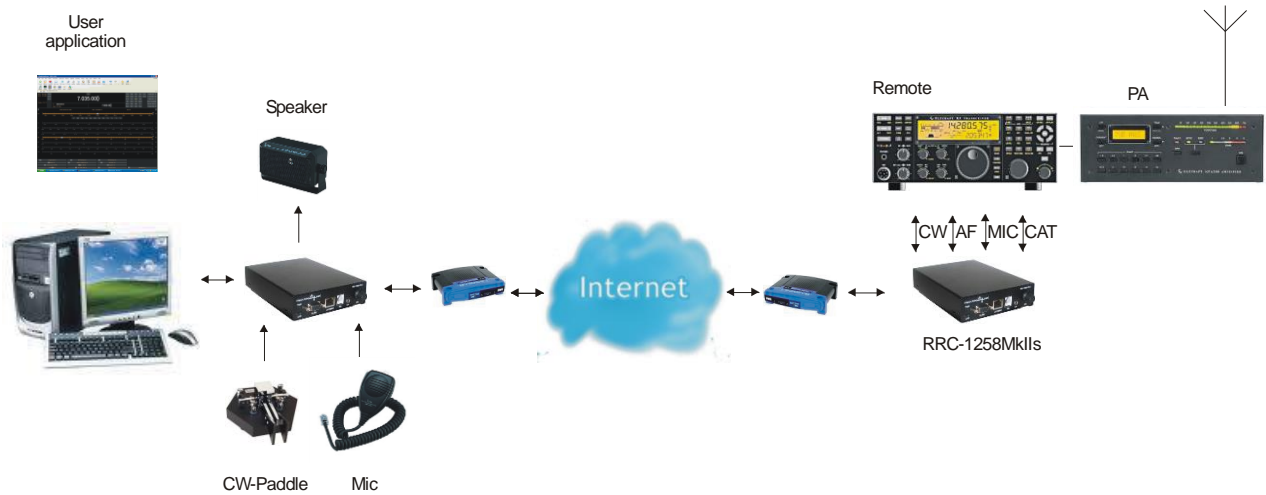

The Remoterig system works with both Elecraft K2 and K3.

Hardware configuration

Elecraft K3

RRC-1258MkII Control		RRC-1258MkII Radio	
	JMP1 DC To Mic	1	
	JMP2 8/9V	1	
	JMP3 RTS-CTS	1	
	JMP5 TTL Pin6	1	
1 = In place, 0 = Not in place, X = doesn't matter			

JMP1 should be in place when using Elecraft MH2 Mic and removed when using for example Heil headset.

Radio settings (example)

Parameter	Control	Radio
Program mode	4 - Yaesu, Kenwood, Elecraft	4 - Yaesu, Kenwood, Elecraft
SIP password	hello	hello
SIP contact	192.168.0.228	
Auto connect	No	
Audio quality	2 - Linear 16 bits 8 kHz	2 - Linear 16 bits 8 kHz
Audio Dual-RX	-	Yes/No
Codec out gain	255	255
Codec inp gain	18	0
Codec inp preamp	Yes	
Codec inp HPF Hz	163	163
COM0 baudrate	9600	9600
COM0 data bits	8	8
COM0 stop bits	1	1
COM0 parity	0 - Off	0 - Off

(*) Available only in RRC-1258MKIIs, remember that the bandwidth demand is doubled.

Connections

Control-RRC:

- Connect a standard RS-232 cable between the PC and the RRC COM2.
- The microphone can be connected direct to the RRC AUX/MIC connector if you have a microphone with RJ-45 connector. If you have a microphone with a circular connector you can use the Remoterig K14a cable, use the MJ-88, from Kenwood or make one by yourself (drawings are provided).
- The speaker is connected direct to the RRC SP-jack with a 3.5 mm stereo plug.

Radio-RRC:

- From the RRC COM2 connector to the radios KIO3 module connector (D-sub RS-232) you use a standard RS-232 cable.
- Between the RRC AUX/MIC connector and the radios circular microphone jack you can use the Remoterig K15a cable or make an adapter cable by yourself (drawings are provided). Make the cable as short as possible to prevent it from picking up HF.
- The speaker signal from the radios external speaker jack to the RRC SP jack is connected via a standard "off- the-shelf" cable with 3.5 mm stereo plugs in both ends.



E1a,E2a



E1c,E2c

DET NR	CNT	NAME		DIMENSION	NOTE
CONSTR	DRAWN	CHECKED	STAND.	SCALE	REPLACE
MS		OK		1:2	REPLACED BY
microbit		Generic Elecraft cable Control -> RRC-1258MkII			DATE
					100220
		DRAWING NR			1258 Cable E1 1(1)

RRC-1258MkII

8-pol RJ 45 Con

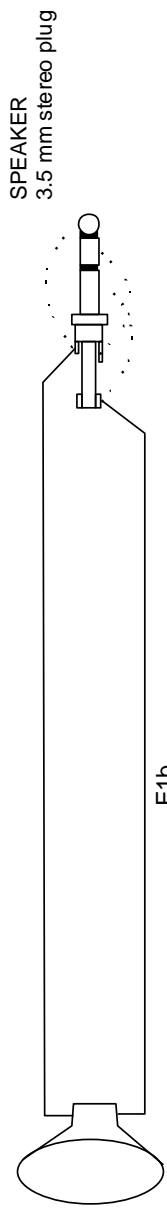
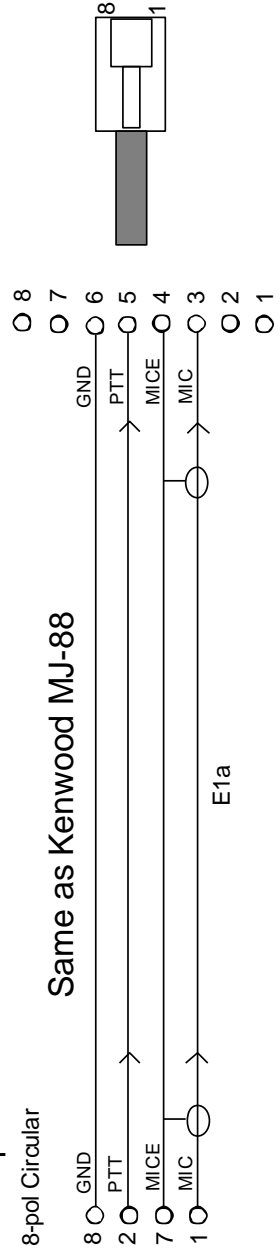

RRC-1258MkII
Speaker/Headset Connector

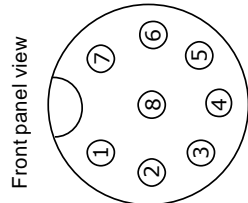
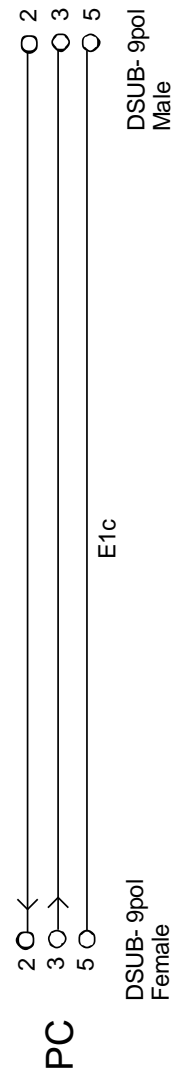

DET NR.	CNT	NAME		DIMENSION		NOTE	
CONSTR.	DRAWN	CHECKED	STAND.	OK	SCALE	REPLACE	REPLACED BY
MS		Generic Elecraft cable RRC-1258MKII -> Radio		1:2			
		DATE		DRAWING NR		100915	
						1258 Cable E2 1(1)	

RRC-1258MKII

8-pol RJ 45 Con

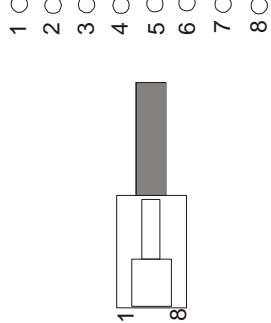

Mic Inp
8-pol Circular

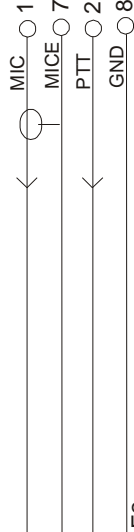

Front panel view

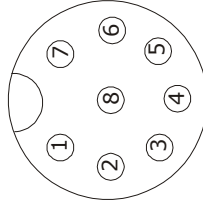

SPEAKER
3.5 mm stereo plug

SPEAKER
3.5 mm stereo plug



RRC-1258MKII

COM2
DSUB- 9pol
Female



Radio RS-232 port

DSUB- 9pol
Male

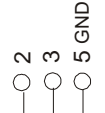

E2c

ALINCO DX-SR8 and DX-R8

General

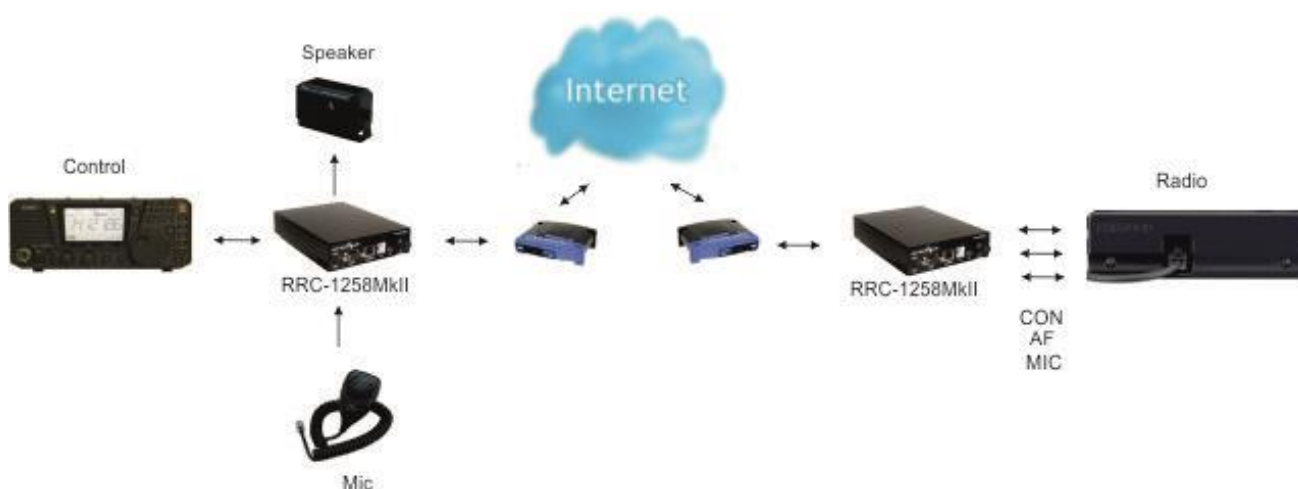

The technical solution for the transceiver Alinco DX-SR8 and the receiver DX-R8 is the same as for IC-703/706, TS480 and TS-2000. All those transceivers are built in the way that the control panel is working separated from the radio unit itself. We replace the cable between panel and radio with to RRC-1258, one connected to the control panel and one connected to the radio. When you press the power button on the panel the radio comes to life at the remote side and audio and panel info flows across the internet between the RRC:s. The look and feel of the control panel is the same as if the panel was directly connected to the radio.

Hardware configuration

DX-SR8

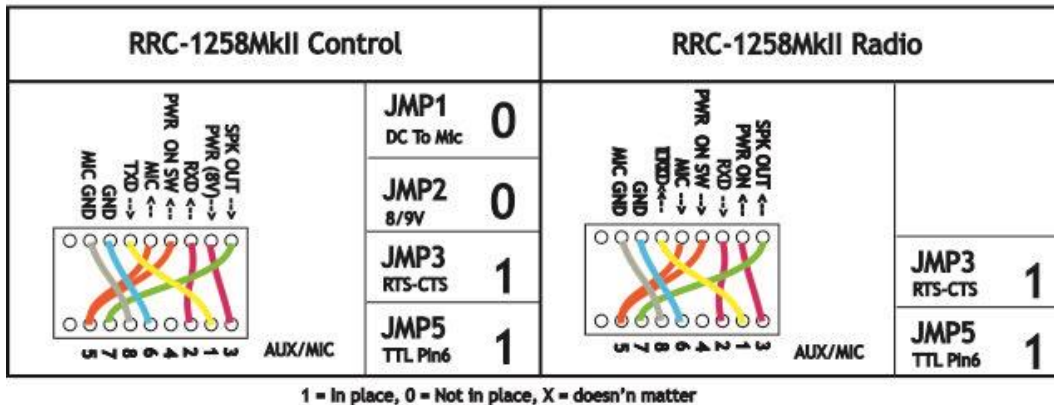

Radio settings (example)

Parameter	Control	Radio
Program mode	12 - DX-SR8	12 - DX-SR8
SIP password	hello	hello
SIP contact	192.168.0.228	
Auto connect	No	
Audio quality	2 - Linear 16 bits 8 kHz	2 - Linear 16 bits 8 kHz
Audio dual-rx (*)		No
Codec out gain	255	255
Codec inp gain	12	0
Codec inp preamp	Yes	
Codec inp HPF Hz	163	163
COM0 baudrate	38400	38400
COM0 data bits	8	8
COM0 stop bits	1	1
COM0 parity	0 - Off	0 - Off

(*) Available only in RRC-1258MkIIs.

Connections

All necessary signals between the panel and the radio are connected with the 8 wires in the connection cable, a standard patch cable. We just need to use two standard patch cables, one between the control panel and the Control-RRC and the other one between the Radio-RRC and the radio. Convenient for travelling is that the speaker is already present on the back of the control panel so there is no need for an extra speaker even if a bigger separate speaker gives better audio. The following signals are represented in the connection cable:

- 1 TXD - data from radio to control panel
- 2 RXD - data from Control panel to radio

- 3 8V - power to control panel (when radio is switched on)
- 4 Not in use
- 5 Mic signal / PWR on/off button
- 6 GND
- 7 AF - Audio to speaker.
- 8 SPK GND - Speaker ground

Power supply

Control-RRC:

The Control-RRC is supplied with a common 13.8 V (10-18V) power supply. The display and speaker amplifier needs a lot of power so you need at least 1A.

RRC-1258MkII with 2-wire or 4-wire interfaces

General

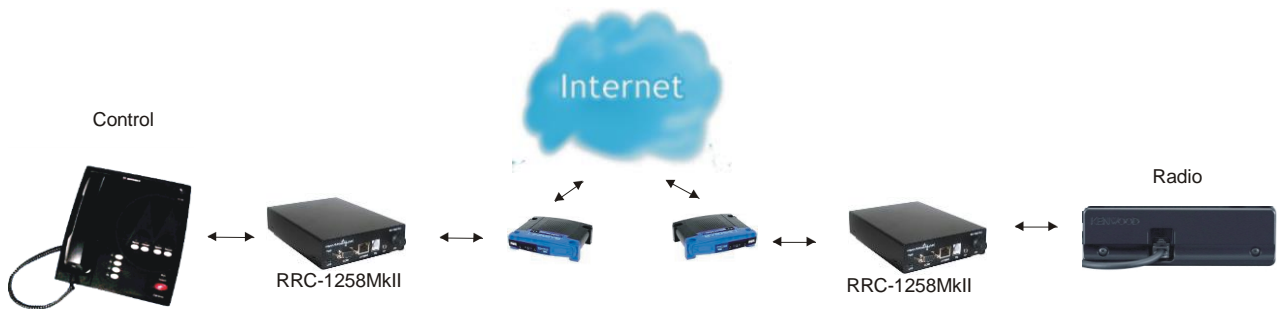

The RRC versions with 2-wire and 4-wire interfaces are mainly used for remote control of commercial radio systems which was designed for leased 2 or 4 wire lines. The interfaces are balanced and are using transformers for isolation nominal impedance is 600 ohm resistive. The 4-wire version can be order with opto couplers for transfer of E and M signals. Nominal audio level is -10 dBm and max level is about +4 dBm. The system also supports transfer of two independent serial ports.

Hardware configuration

The Interface PCB for 2 and 4-wires must be installed at factory. No other strappings needed.



Radio settings (example)

Parameter	Control	Radio
Program mode	11 – Transparent 4-wire	11 – Transparent 4-wire
SIP password	hello	hello
SIP contact	192.168.0.228	
Auto connect	Yes	
Audio quality	2 – Linear 16 bits 8 kHz	2 – Linear 16 bits 8 kHz
Audio dual-rx (*)		No
Codec out gain	255	255
Codec inp gain	14 (4w)/12 (2w)	14 (4w) /12 (2w)
Codec inp preamp	Yes	
Codec inp HPF Hz	163	163
COM0 baudrate	9600	9600
COM0 data bits	8	8
COM0 stop bits	1	1
COM0 parity	0 - Off	0 - Off

(*) Not applicable.

Connections

AUX/MIC

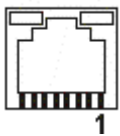

Pin no	2-wire Interface	4-wire Interface
	AUX (RJ45)	AUX (RJ45)
1		E-In [-]*
2		M-Out*
3		4-wire in [b]
4	2-wire [a]	4-wire out [a]
5	2-wire [b]	4-wire out [b]
6		4-wire in [b]
7		M-Out*
8		E-In [+]*

(*) E/M support have to be ordered separate.

Power supply

Control-RRC:

The Control-RRC is supplied with a common 13.8 V (10-18V) 1A power supply.

Schematics

I/O and PAD interface

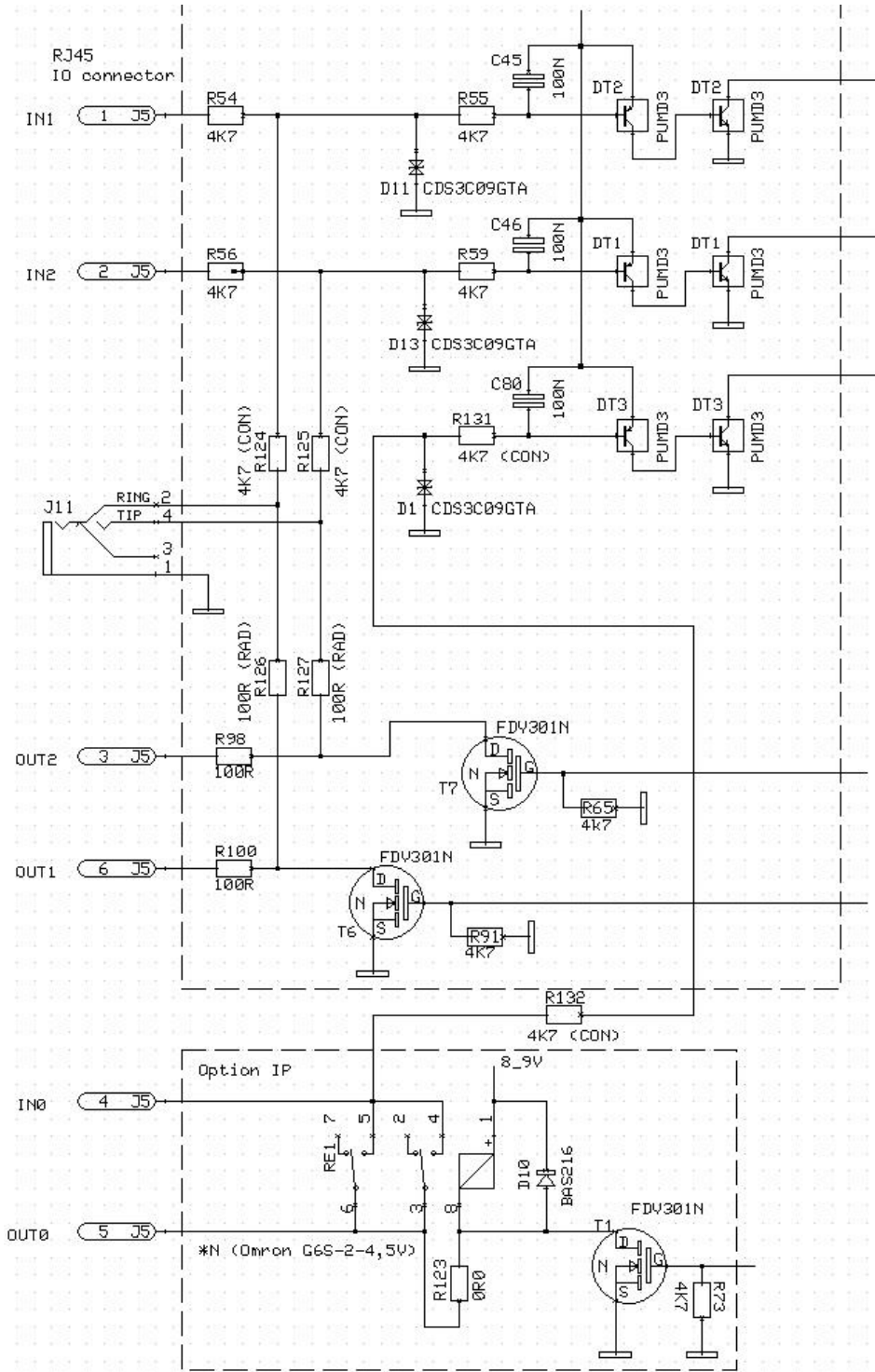

MIC/AUX Interface Control-RRC MkII

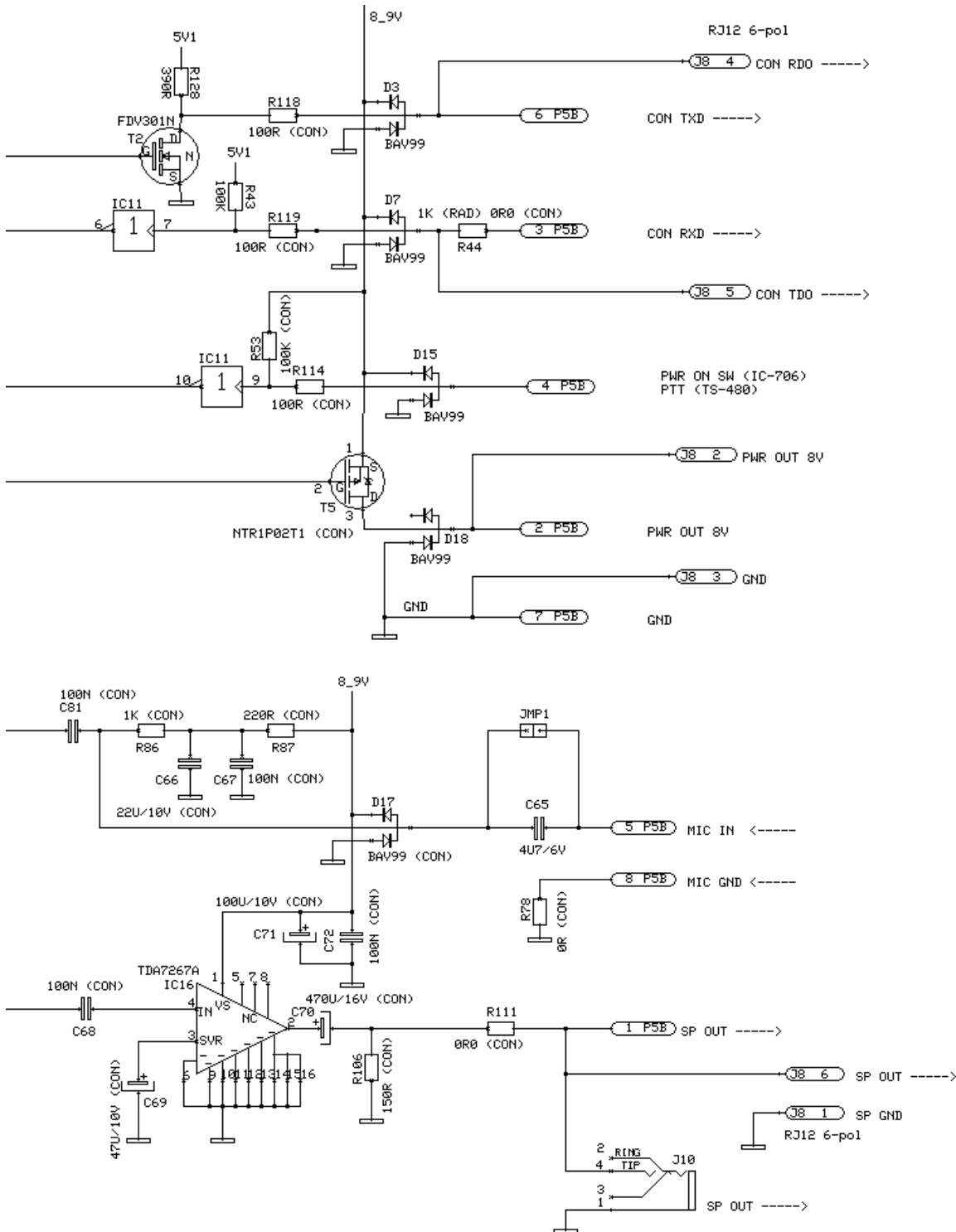

Speaker output interface Control-RRC MkIIs

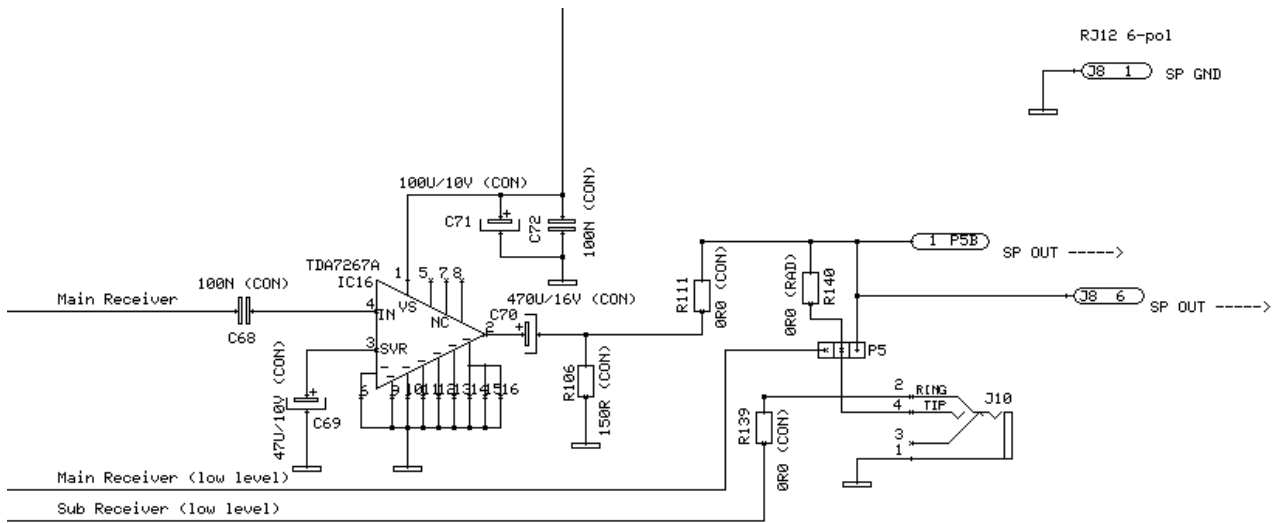

Speaker input interface Radio-RRC MkIIs

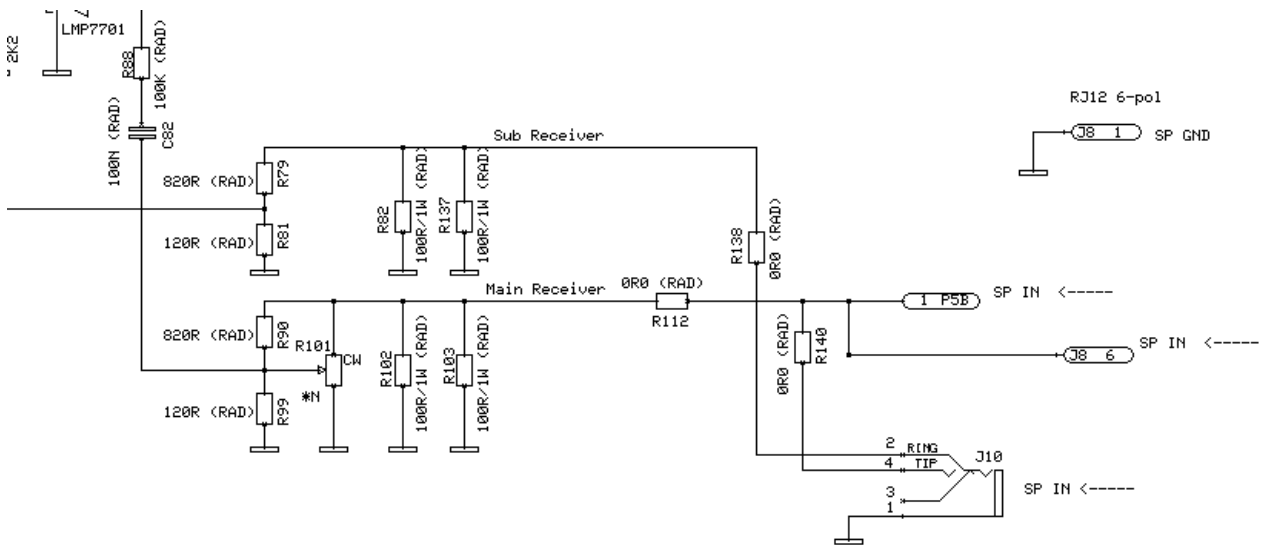

MIC/AUX Interface Radio-RRC

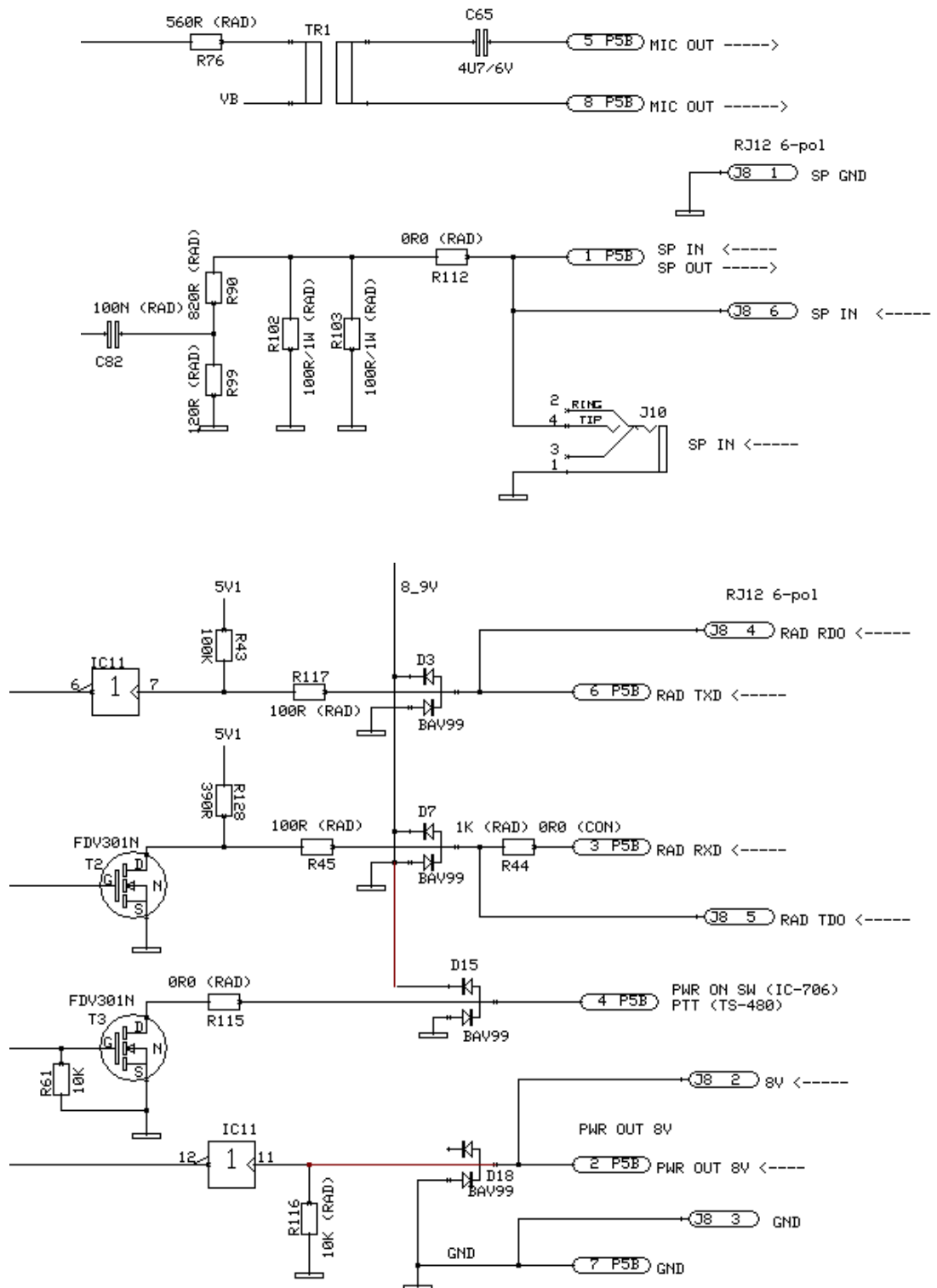

Networks and Firewalls

One of the major obstacles when trying to remotely control something is the fact that the Internet Service Provider (ISP) forces us to use dynamic IP addresses. We can never know, from time to time, which IP address our modem / firewall / router has on its outside interface (the IP address you will try to connect to). Most people use NAT routers that translates IP addresses on the inside (your little LAN) to one common IP address on the outside using port conversion.

To be able to stream audio and at the same time transfer CAT / CI-V commands or panel-to-radio communications' we need to know which IP port numbers are used for each service. There are some different techniques to fix this.

At the operator end (Control-RRC) there is normally OK just to use DHCP for the own IP-settings. For the Sip contact parameter you enter the public fixed IP address or Dynamic DNS-name to the router at the radio site.

At the radio end (Radio-RRC) the router must be configured so that port 13000, 13001, 13002 and 80 (default settings) are directed to the Radio-RRC which should have a static IP address. The easy way to get connected is to set the RRC IP address as DMZ server in the router. This makes it possible to connect to all services (SIP, audio and control) as well as the web and telnet interfaces without further configuration. If you run a web server at the radio site you need to change the webserver port from 80 to something else, for example 8000. Port 80 can also be blocked by the ISP. If you are using port forwarding you have to configure the router in a way that every service forwards packets to the right host on the inside.

When setting up the router check that there is No SIP ALG activated.

You will also need to register the Radio-RRC to a Dynamic DNS Service so you can use a host name to connect to the Radio-RRC regardless of its dynamic IP address (which can change without notice, but rarely does).

The following default IP ports are used (changeable)

port number	Protocol	function
13000	UDP	SIP (change this port number in both ends if you are using SIP based IP-telephony)
13001	UDP	RTP, audio
13002	UDP	DATA channel, control commands
80	TCP	WEB interface
23	TCP	Telnet Interface

In earlier firmwares, other default ports where used (eg 12000,11000,5060,80,23)

DMZ

A typical setup screen for activating DMZ is shown below.

Enter the IP-number of the Radio-RRC in box and enable DMZ.

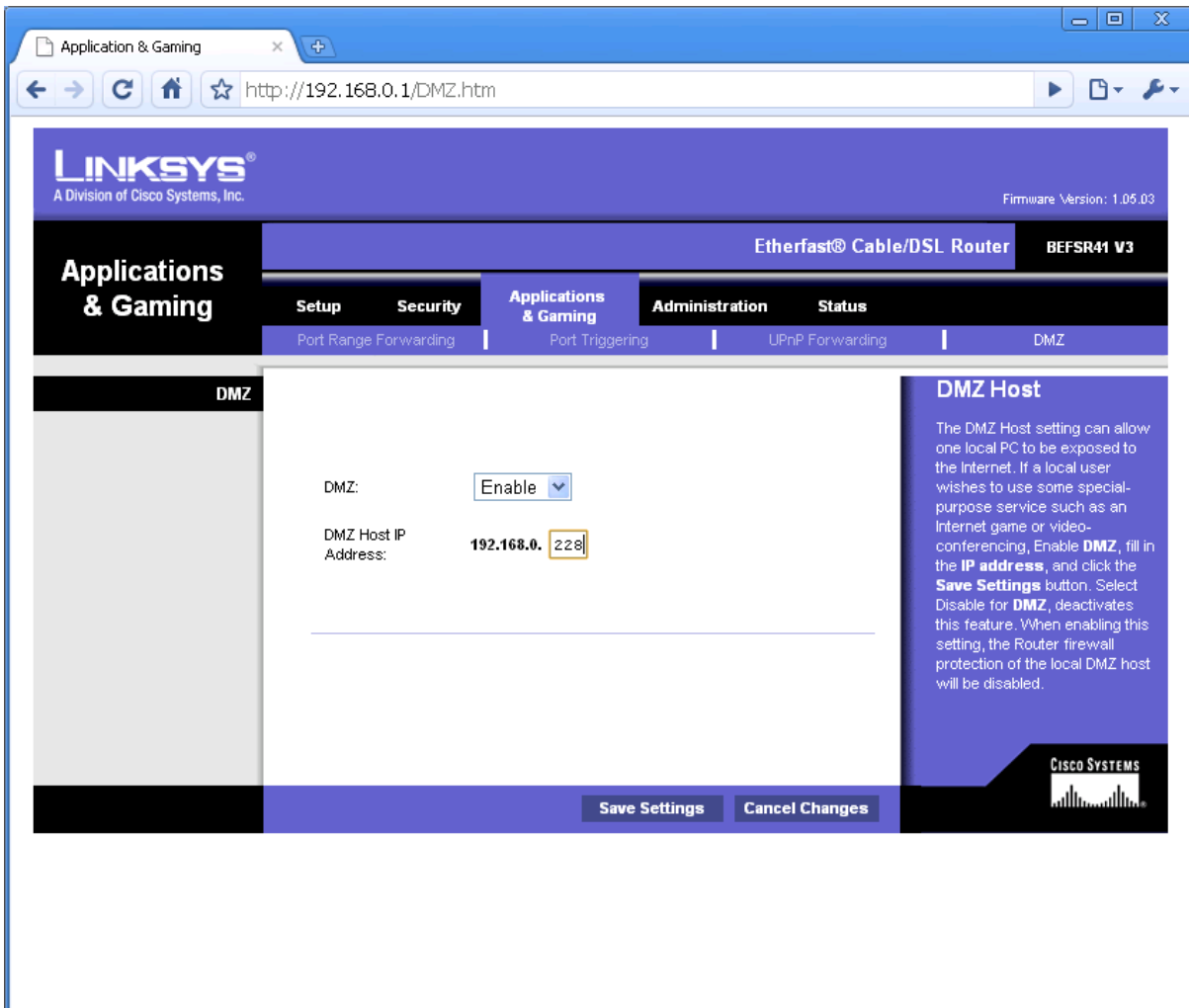

Portforwarding

A typical setup screen for activating port forwarding is shown below.

There is one row assigned for each port (service) all refereeing to the IP of the Radio-RRC

The screenshot shows the Linksys web interface for an Etherfast Cable/DSL Router (BEFSR41 V3). The page is titled "Port Range Forwarding" and is part of the "Applications & Gaming" section. The interface includes a navigation menu with options like "Setup", "Security", "Applications & Gaming", "Administration", and "Status". Under "Applications & Gaming", there are sub-options: "Port Range Forwarding", "Port Triggering", "UPnP Forwarding", and "DMZ".

The main content area features a table titled "Port Range" with the following columns: Application, Start, End, Protocol, IP Address, and Enabled. The table contains several rows, each representing a port forwarding rule. The first four rows are pre-configured with specific applications and ports, while the remaining rows are empty for user configuration.

Application	Start	End	Protocol	IP Address	Enabled
RRC_SIP	13000 to	13000	UDP	192.168.0.228	<input checked="" type="checkbox"/>
RRC_RTP	13001 to	13001	UDP	192.168.0.228	<input checked="" type="checkbox"/>
RRC_CMD	13002 to	13002	UDP	192.168.0.228	<input checked="" type="checkbox"/>
RRC_WEB	80 to	80	TCP	192.168.0.228	<input checked="" type="checkbox"/>
	0 to	0	Both	192.168.0.0	<input type="checkbox"/>
	0 to	0	Both	192.168.0.0	<input type="checkbox"/>
	0 to	0	Both	192.168.0.0	<input type="checkbox"/>
	0 to	0	Both	192.168.0.0	<input type="checkbox"/>
	0 to	0	Both	192.168.0.0	<input type="checkbox"/>
	0 to	0	Both	192.168.0.0	<input type="checkbox"/>

At the bottom of the page, there are two buttons: "Save Settings" and "Cancel Changes".

On the right side, there is a sidebar titled "Port Range Forwarding" containing a help text: "Port Range Forwarding can be used to set up public services on your network. When users from the Internet make certain requests on your network, the Router can forward those requests to computers equipped to handle the requests. If, for example, you set the port number 80 (HTTP) to be forwarded to IP Address 192.168.1.2, then all HTTP requests from outside users will be forwarded to 192.168.1.2. **It is recommended that the computer use static IP address.** You may use this function to establish a web server or FTP server via an IP Gateway. Be sure that you enter a valid [More...](#)

SIP ALG

If the router has a parameter called **SIP ALG** it should always be **Disabled** in both the Control and radio end.

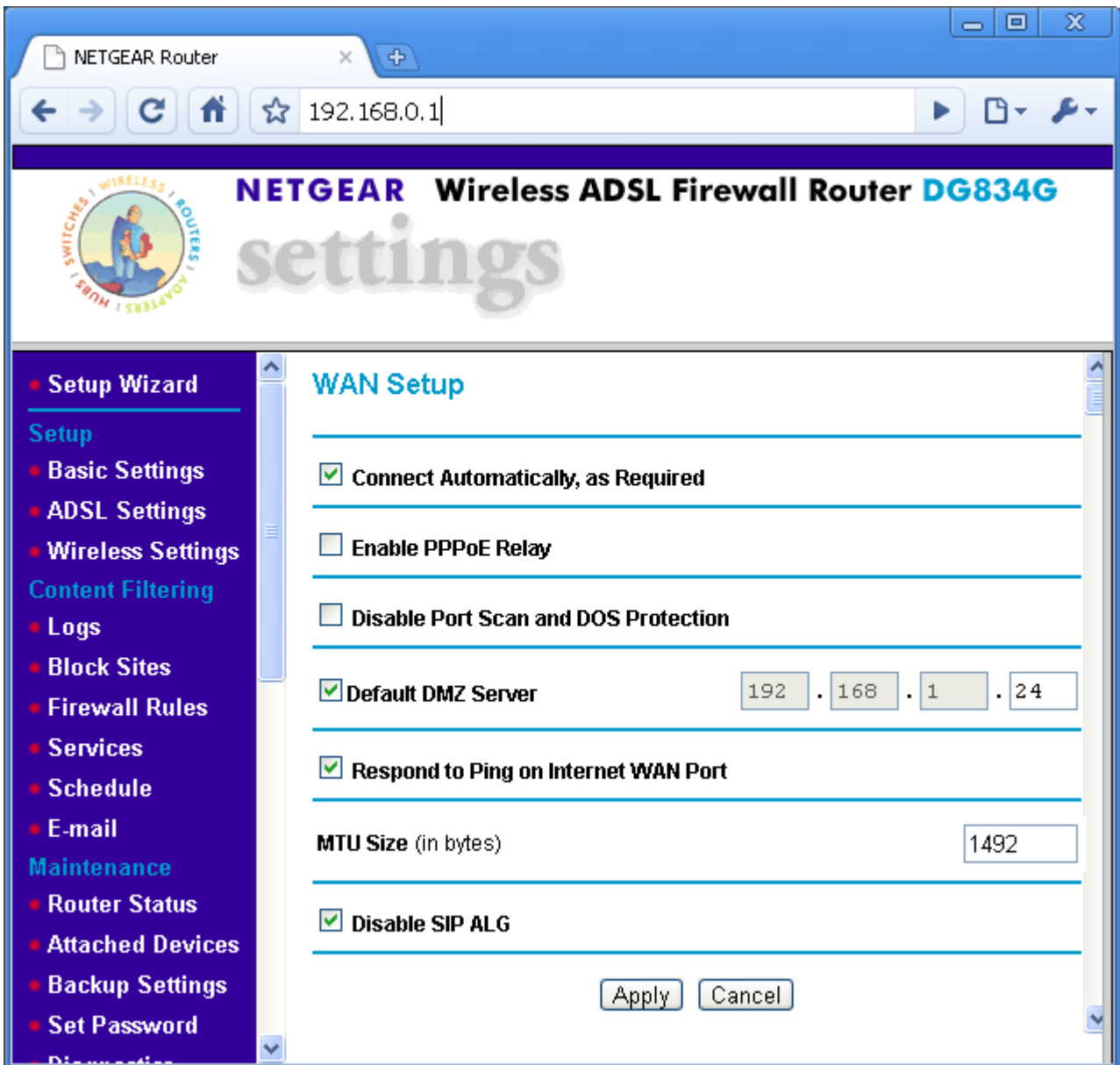

Mobile Network Routers

The Remoterig system can be used with mobile networks routers also. They are often called 3G or 4G/LTE routers. They are configured in the same way as a normal router. Before you order your 3G or 4G subscription check with the operator that they allow inbound connections from outside Internet, some operators do not, and you need that if you will have a mobile router at the radio site. Be aware of that 3G (not 4G/LTE) connection often add latency up to 100-150 ms even if the bandwidth is high enough. This can make CW difficult but is seldom a problem for voice communication. With 3G we don't recommend using mobile connection in both ends, with 4G/LTE it's possible.

How to check if the ISP uses Carrier-grade NAT (CGN)

It has been more and more common that mobile telephone operators has changed to CGN for their internet connections to save IPv4 addresses. CGN is no problem for most subscribers if they only need to browse the web sending emails etc. But it makes communication in the other direction, from outside Internet and in, impossible. This means that a Remoterig Radio-RRC cannot be used with an ISP using CGN. For the control-RRC it's OK. In most cases it's possible to get a subscription with real public IP-addresses from the ISP but in some cases you have to pay extra for it.

More info about CGN https://en.wikipedia.org/wiki/Carrier-grade_NAT

To check if your ISP is using CGN you need to connect a PC to the router which has the a SIM card installed for the ISP you want to test.

When you are up and in connection with the Internet and can browse the web go to

<http://www.whatsmyip.org/>

or any similar page which will show from which public IP address your request is coming. This address is always a public IP-address, nothing else works.

After that, login to your router and look at the status page. The router will report which WAN IP-address it has got from the ISP.

If it shows the same IP-address as whatsmyip everything is OK and it will work with Remoterig.

If the router shows another WAN IP-address it's NOT OK, the ISP is using CGN.

If CGN is in use the router often shows a WAN IP address like 100.xxx.xxx.xxx or 10.xxx.xxx.xxx.or 192.xxx.xxx.xxx.

If your ISP is using CGN you must talk to him and tell him that you cannot use a subription with CGN you must have a public IP-address.

Note! This is only important at the Radio side.

Appendix A - Audio coding

Quality 1 or 2 is recommended for short wave listening, they are good compromises between quality and need for bandwidth. Practical test have shown that quality 0 (G711) is not the optimal coding if the signal to noise ratio is low which is common on the shortwave bands. Quality 8 gives a very good audio quality even if you listen to music on FM. 16 kHz sample rate and 16 bits deep gives a very good dynamic range and a large SNR and good audio bandwidth. Quality 11 and 12 can be used when very limit bandwidth is available, the audio quality is reduced. The other qualities are more of academic interest. A good speaker is always a good investment also.

Note – Different codings can be used in the uplink and downlink, which can be useful in asymmetrical Internet links like ADSL and most mobile systems. Sample rate must be same in both ends but coding can be different.

Audio quality	Coding	Sample rate [kHz]	Bandwidth dual-rx=0 [kbps]	Packet size dual-rx=0 [ms]	Bandwidth dual-rx=1 [kbps]	Packet size dual-rx=1 [ms]
0	A-law (G711)	8	80	20	160	20
1	Linear-12bits	8	120	20	240	20
2	Linear-16bits	8	160	20	320	20
3	A-law (G711)	12	120	20	240	20
4	Linear-12bits	12	180	20	360	17,8
5	Linear-16bits	12	240	20	480	13,3
6	A-law (G711)	16	160	20	320	20
7	Linear-12bits	16	240	20	480	13,3
8	Linear-16bits	16	320	20	640	10
9	A-law (G711)	24	240	20	480	13,3
10	Linear-12bits	24	360	17,8	720	8,9
11	Linear-16bits	24	480	13,3	960	6,7
12	IMA ADPCM 4bits	8	48	20	96	10
13	IMA ADPCM 4bits	16	96	20	192	10

Appendix B - COM-port Keyer interface

There are lots of different solutions on the Internet, but this is very simple and can be implemented in the D-sub housing. No values are critical; just use what you have in the junk box.

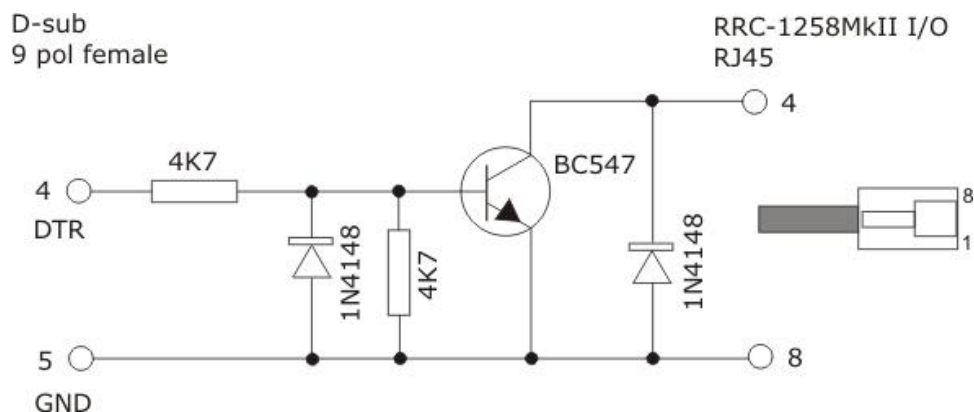

Appendix D - Technical Data

Product/Art no:	Remoterig RRC-1258MkII
Dimensions (LxHxD):	165 x 140 x 34 mm
Weight:	2 x 250 g (excl. power supply)
Ip class:	IP20
Power supply requirement:	10-18V DC via DC Plug 2.1 mm/5.5mm
Current drain at 13,8V:	App. 160 mA up to app. 600 mA depending on audio level and ev. Back-lighter
Network connection:	RJ45 T-Base10/100
Speaker amplifier:	2 x 2W (8 ohm)
Mic input:	Dynamic or Electret with DC feed
Radio protocol (detachable front):	Kenwood TS-480, TM-D710, TS-2000 ICOM IC-703, IC-706, IC-E2820, IC-R2500, IC-2725, FT-857, FT-100, FT-7800/8800/8900, FTM-350, Alinco SR-DX8
Radio protocol (traditional control):	ICOM CI-V, Kenwood PC-control, Yaesu CAT, Elecraft
Protocol Internet:	TCP/IP, UDP, DHCP, SIP, RTP, DNS, DynDNS etc.
Codec:	G711 A-law (8kHz/8bit), 8kHz/16bit, 16kHz/16bit mm.
Bandwidth demands:	From app. 90 Kbit/s up to app 1 Mbit/s depending on codecs and settings.
USB:	USB 2.0 (mini)
Serial ports (transparent):	2 x RS-232 (57600 baud) 1 x TTL (57600 baud)
CW-keyer:	10-40 WPM, Iambic A/B, Squeeze, side-tone
Usable temp range:	0 to +40 °C
Humidity range:	30% to 90% RH



Appendix E - Safety and Regulatory Information

FCC Statement

This device complies with Part 15 of the FCC Rules. Operation is subject to the following two conditions:

- This device may not cause harmful interference.
- This device must accept any interference received, including interference that may cause undesired operation.

This equipment has been tested and found to comply with the limits for a Class B digital device, pursuant to part 15 of the FCC Rules. These limits are designed to provide reasonable protection against harmful interference in a residential installation. This equipment generates, uses, and can radiate radio frequency energy and, if not installed and used in accordance with the instructions, may cause harmful interference to radio communications. However, there is no guarantee that interference will not occur in a particular installation. If this equipment does cause harmful interference to radio or television reception, which can be determined by turning the equipment off and on, the user is encouraged to try to correct the interference by one or more of the following measures:

- Reorient or relocate the receiving antenna.
- Increase the separation between the equipment and receiver.
- Connect the equipment into an outlet on a circuit different from that to which the receiver is connected.
- Consult the dealer or an experienced radio/TV technician for help.

FCC Caution: Any changes or modification not expressly approved by the party responsible for compliance could void the user's authority to operate the equipment.

Safety Notice

- Do not use this product near water, for example, in a wet basement or near a swimming pool.
- Avoid using this product during an electrical storm. There may be a remote risk of electric shock from lightning.
- Warning: Never operate this device with a headset or other audio accessories at high volume levels. Hearing expert's advice against continuous high volume operation, if you experience a ringing in your ears, reduce the volume level or discontinue use.
- Never connect a power supply of more than 18 VDC to the power jack. The supply voltage must be between 10 V and 18 V. to prevent damaging the device.

Disclaimer

The author has written this document to the best of his knowledge, but does not guarantee that the contents will satisfy the desire and expectation of the reader. The author or Microbit takes no responsibility for damage or injuries of any kind that may arise from the use and miss use of the product or information contained. The author do not warrant the accuracy and correctness of the information contained. All brand and names mentioned are trademarks or registered trademarks of their respective holders.

FCC / CE - Declaration of conformity



DECLARATION OF CONFORMITY

We, the manufacturer,
Microbit 2.0 AB
Nystaden 1
SE-952 61 KALIX
Sweden

Declares that the product
Type of equipment : IP Remote unit
Brand name/Trade mark: Remoterig RRC-1258 MkII
Type / model : 1258B

Is in compliance with the essential requirements and other relevant provisions of FCC Part 15.

The product is compatible with the following norms / standards:

- ANSI 63.4 Class B

Kalix 2010-04-27



Mikael Styrefors



DECLARATION OF CONFORMITY

We, the manufacturer,
Microbit 2.0 AB
Nystaden 1
SE-952 61 KALIX
Sweden

Declares that the product
Type of equipment : IP Remote unit
Brand name/Trade mark: Remoterig RRC-1258 MkII
Type / model : 1258B

Is in compliance with the essential requirements and other relevant provisions of the following directives:

- Electromagnetic Compatibility Directive (EMC) 2004/108/EC
- Low Voltage Directive (LVD), 2006/95/EC

The product is compatible with the following norms / standards:

EMC: EN 61000-6-3, EN 55 022(2006) and A1
EN 55 024(1998) and A1(2001), A2(2003)

LVD: EN 60950:2006

Kalix 2009-10-11



Mikael Styrefors

Appendix F - Contact Information

Support site	www.remoterig.com
E-mail	info@microbit.se
Web site	www.microbit.se
Phone	+46 923 69620